



FR541V, FR600V

FS481V, FS541V, FS600V

FX481V, FX541V, FX600V



**4-Stroke Air-Cooled V-Twin Gasoline Engine**  
**Service Manual**



# Quick Reference Guide

<b>General Information</b>	<b>1</b>
<b>Periodic Maintenance</b>	<b>2</b>
<b>Fuel System</b>	<b>3</b>
<b>Cooling System</b>	<b>4</b>
<b>Engine Top End</b>	<b>5</b>
<b>Lubrication System</b>	<b>6</b>
<b>Camshaft/Crankshaft</b>	<b>7</b>
<b>Starter System</b>	<b>8</b>
<b>Electrical System</b>	<b>9</b>
<b>Troubleshooting</b>	<b>10</b>

This quick reference guide will assist you in locating a desired topic or procedure.

- Bend the pages back to match the black tab of the desired chapter number with the black tab on the edge at each table of contents page.
- Refer to the sectional table of contents for the exact pages to locate the specific topic required.





**FR541V, FR600V**  
**FS481V, FS541V, FS600V**  
**FX481V, FX541V, FX600V**

## **4-Stroke Air-Cooled V-Twin Gasoline Engine**

# **Service Manual**

---

All rights reserved. No parts of this publication may be reproduced, stored in a retrieval system, or transmitted in any form or by any means, electronic mechanical photocopying, recording or otherwise, without the prior written permission of Quality Assurance Division/Motorcycle & Engine Company/Kawasaki Heavy Industries, Ltd., Japan.

No liability can be accepted for any inaccuracies or omissions in this publication, although every possible care has been taken to make it as complete and accurate as possible.

The right is reserved to make changes at any time without prior notice and without incurring an obligation to make such changes to products manufactured previously.

All information contained in this publication is based on the latest product information available at the time of publication. Illustrations and photographs in this publication are intended for reference use only and may not depict actual model component parts.

---

## LIST OF ABBREVIATIONS

A	ampere(s)	lb	pound(s)
ABDC	after bottom dead center	m	meter(s)
AC	alternating current	min	minute(s)
ATDC	after top dead center	N	newton(s)
BBDC	before bottom dead center	Pa	pascal(s)
BDC	bottom dead center	PS	horsepower
BTDC	before top dead center	psi	pound(s) per square inch
°C	degree(s) Celsius	r	revolution
DC	direct current	rpm	revolution(s) per minute
F	farad(s)	TDC	top dead center
°F	degree(s) Fahrenheit	TIR	total indicator reading
ft	foot, feet	V	volt(s)
g	gram(s)	W	watt(s)
h	hour(s)	Ω	ohm(s)
L	liter(s)		

## EMISSION CONTROL INFORMATION

To protect the environment in which we all live, Kawasaki has incorporated crankcase emission (1) and exhaust emission (2) control systems (EM) in compliance with applicable regulations of the United States Environmental Protection Agency and California Air Resources Board.

### 1. Crankcase Emission Control System

A sealed-type crankcase emission control system is used to eliminate blow-by gases. The blow-by gases are led to the breather chamber through the crankcase. Then, it is led to the air cleaner.

Oil is separated from the gases while passing through the inside of the breather chamber from the crankcase, and then returned back to the bottom of crankcase.

### 2. Exhaust Emission Control System

The exhaust emission control system applied to this engine consists of a carburetor and an ignition system having optimum ignition timing characteristics.

The carburetor has been calibrated to provide lean air/fuel mixture characteristics and optimum fuel economy with a suitable air cleaner and exhaust system.

## TAMPERING WITH EMISSION CONTROL SYSTEM PROHIBITED

Federal law and California State law prohibits the following acts or the causing thereof: (1) the removal or rendering inoperative by any person other than for purposes of maintenance, repair, or replacement, of any device or element of design incorporated into any new engine for the purpose of emission control prior to its sale or delivery to the ultimate purchaser or while it is in use, or (2) the use of the engine after such device or element of design has been removed or rendered inoperative by any person.

Among those acts presumed to constitute tampering are the acts listed below:

Do not tamper with the original emission related part:

- Carburetor and internal parts
- Spark plugs
- Magneto or electronic ignition system
- Fuel filter element
- Air cleaner elements
- Crankcase
- Cylinder heads
- Breather chamber and internal parts
- Intake pipe and tube

# Foreword

This manual is designed primarily for use by trained mechanics in a properly equipped shop. However, it contains enough detail and basic information to make it useful to the owner who desires to perform his own basic maintenance and repair work. A basic knowledge of mechanics, the proper use of tools, and workshop procedures must be understood in order to carry out maintenance and repair satisfactorily. Whenever the owner has insufficient experience or doubts as to his ability to do the work, all adjustments, maintenance, and repair should be carried out only by qualified mechanics.

In order to perform the work efficiently and to avoid costly mistakes, read the text, thoroughly familiarize yourself with the procedures before starting work, and then do the work carefully in a clean area. Whenever special tools or equipment are specified, do not use makeshift tools or equipment. Precision measurements can only be made if the proper instruments are used, and the use of substitute tools may adversely affect safe operation.

To get the longest life out of your engine:

- Follow the Periodic Maintenance Chart in the Service Manual.
- Be alert for problems and non-scheduled maintenance.
- Use proper tools and genuine Kawasaki engine parts. Genuine parts provided as spare parts are listed in the Parts Catalog.
- Follow the procedures in this manual carefully. Don't take shortcuts.
- Remember to keep complete records of maintenance and repair with dates and any new parts installed.

---

## How to Use This Manual

---

In this manual, the product is divided into its major systems and these systems make up the manual's chapters. The Quick Reference Guide shows you all of the product's system and assists in locating their chapters. Each chapter in turn has its own comprehensive Table of Contents.

For, example, if you want ignition coil information, use the Quick Reference Guide to locate

the Electrical System chapter. Then, use the Table of Contents on the first page of the chapter to find the Ignition Coil section.

Whenever you see these symbols, heed their instructions! Always follow safe operating and maintenance practices.

### **DANGER**

**DANGER** indicates a hazardous situation which, if not avoided, will result in death or serious injury.

### **WARNING**

**WARNING** indicates a hazardous situation which, if not avoided, could result in death or serious injury.

### **NOTICE**

**NOTICE** is used to address practices not related to personal injury.

This manual contains four more symbols which will help you distinguish different types of information.

### **NOTE**

○ *NOTE* indicates information that may help or guide you in the operation or service of the vehicle.

- Indicates a procedural step or work to be done.
- Indicates a procedural sub-step or how to do the work of the procedural step it follows. It also precedes the text of a NOTE.
- ★ Indicates a conditional step or what action to take based on the results of the test or inspection in the procedural step or sub-step it follows.

In most chapters an exploded view illustration of the system components follows the Table of Contents. In these illustrations you will find the instructions indicating which parts require specified tightening torque, oil, grease or a locking agent during assembly.

# General Information

## Table of Contents

Before Servicing .....	1-2
Model Identification.....	1-5
General Specifications.....	1-8



## 1-2 GENERAL INFORMATION

---

### Before Servicing

---

Before starting to service the engine, carefully read the applicable section to eliminate unnecessary work. Photographs, diagrams, notes, cautions, warnings, and detailed descriptions have been included wherever necessary. Nevertheless, even a detailed account has limitations, a certain amount of basic knowledge is required for successful work.

#### Especially note the following

(1) Dirt

Before removal and disassembly, clean the engine. Any dirt entering the engine, carburetor, or other parts, will work as an abrasive and shorten the life of engine. For the same reason, before installing a new part, clean off any dust or metal filings.

(2) Battery Ground

Remove the ground (–) lead from the battery before performing any disassembly operations on the equipment. This prevents:

- (a) the possibility of accidentally turning the engine over while partially disassembled.
- (b) sparks at electrical connections which will occur when they are disconnected.
- (c) damage to electrical parts.

(3) Tightening Sequence

Generally, when installing a part with several bolts, nuts, or screws, start them all in their holes and tighten them to a snug fit. Then tighten them evenly, in a staggered sequence. This is to avoid distortion of the part and/or causing gas or oil leakage. Conversely when loosening the bolts, nuts, or screws, first loosen all of them by about a quarter of a turn and then remove them. Where there is a tightening sequence indication in this Service Manual, the bolts, nuts, or screws must be tightened in the order and method indicated.

(4) Torque

When torque values are given in this Service Manual, use them. Either too little or too much torque may lead to serious damage. Use a good quality, reliable torque wrench.

(5) Force

Common sense should dictate how much force is necessary in assembly and disassembly. If a part seems especially difficult to remove or install, stop and examine what may be causing the problem. Whenever tapping is necessary, tap lightly using a wooden or plastic-faced mallet. Use an impact driver for screws (particularly for the removal of screws held by a locking agent) in order to avoid damaging the heads.

(6) Edges

Watch for sharp edges, especially during major engine disassembly and assembly. Protect your hands with gloves or a piece of thick cloth when lifting the engine or turning it over.

(7) High Flash-Point Solvent

A high flash-point solvent is recommended to reduce fire danger. A commercial solvent commonly available in North America is Standard solvent (generic name). Always follow manufacturer and container directions regarding the use of any solvent.

(8) Gasket, O-ring

Do not reuse a gasket or O-ring once it has been in service. The mating surfaces around the gasket should be free of foreign matter and perfectly smooth to avoid oil or compression leaks.

(9) Liquid Gasket, Non-Permanent Locking Agent

Follow manufacturer's directions for cleaning and preparing surfaces where these compounds will be used. Apply sparingly. Excessive amounts may block engine oil passages and cause serious damage. An example of a non-permanent locking agent commonly available in North America is Loctite Lock'n Seal (Blue).

(10) Press

A part installed using a press or driver, such as a journal, should first be coated with oil on its outer or inner circumference so that it will go into place smoothly.

(11) Ball Bearing, Needle Bearing

Do not remove a ball bearing or a needle bearing unless it is absolutely necessary. Replace any ball or needle bearings that were removed with new ones. Install bearings with the manufacturer and size marks facing out, applying pressure evenly with a suitable driver to the end of the race that contacts the press fit portion, and press it evenly over the base component.

**Before Servicing**

(12)Oil Seal and Grease Seal

Replace any oil or grease seals that were removed with new ones, as removal generally damages seals.

When pressing in a seal which has manufacturer's marks, press it in with the marks facing out. Seals should be pressed into place using a suitable driver, which contacts evenly with the side of seal, until the face of the seal is even with the end of the hole.

(13)Seal Guide

A seal guide is required for certain oil or grease seals during installation to avoid damage to the seal lips. Before a shaft passes through a seal, apply a little oil, preferably high-temperature grease on the lips to reduce rubber to metal friction.

(14)Circlip, Retaining Ring and Cotter Pin

When installing circlips and retaining rings, take care to compress or expand them only enough to install them and no more. Install the circlip with its chamfered side facing load side as well.

Replace any circlips, retaining rings, and cotter pins that were removed with new ones, as removal weakens and deforms them. If old ones are reused, they could become detached while running, leading to a problem.



(15)Lubrication

Engine wear is generally at its maximum while the engine is warming up and before all the rubbing surfaces have an adequate lubricative film. During assembly, oil or grease (whichever is more suitable) should be applied to any rubbing surface which has lost its lubricative film. Old grease and dirty oil should be cleaned off. Deteriorated grease has lost its lubricative quality and may contain abrasive foreign particles.

Don't use just any oil or grease. Some oils and greases in particular should be used only in certain applications and may be harmful if used in an application for which they are not intended. This manual makes reference to molybdenum disulfide grease (MoS2) in the assembly of certain engine parts. Always check manufacturer recommendations before using such special lubricants.

(16)Electrical Wires

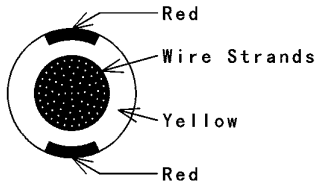
All the electrical wires are either single-color or two-color and, with only a few exceptions, must be connected to wires of the same color. On any of the two-color wires there is a greater amount of one color and a lesser amount of a second color, so a two-color wire is identified by first the primary color and then the secondary color. For example, a yellow wire with thin red stripes is referred to as a "yellow/red" wire; it would be a "red/yellow" wire if the colors were reversed to make red the main color.

Wire (cross-section)	Color Indicated on the Wire	Color Indicated on the Wiring Diagram
	Yellow/Red	

6B020601W1 C

(17)Replacement Parts

When there is a replacement instruction, replace these parts with new ones every time they are removed. There replacement parts will be damaged or lose their original function once removed.

(18)Inspection

When parts have been disassembled, visually inspect these parts for the following conditions or other damage. If there is any doubt as to the condition of them, replace them with new ones.

Abrasion	Crack	Hardening	Warp
Bent	Dent	Scratch	Wear
Color change	Deterioration	Seizure	

(19)Service Data

Service Data terms are defined as follows:

"Standards" show dimensions or performances which brand-new parts or systems have.

## 1-4 GENERAL INFORMATION

---

### Before Servicing

---

“Service Limits” indicate the usable limits. If the measurement shows excessive wear or deteriorated performance, replace the damaged parts.

**Model Identification**

**FX Models (Electric Starter Model)**



**FX Models (Recoil Starter Model)**

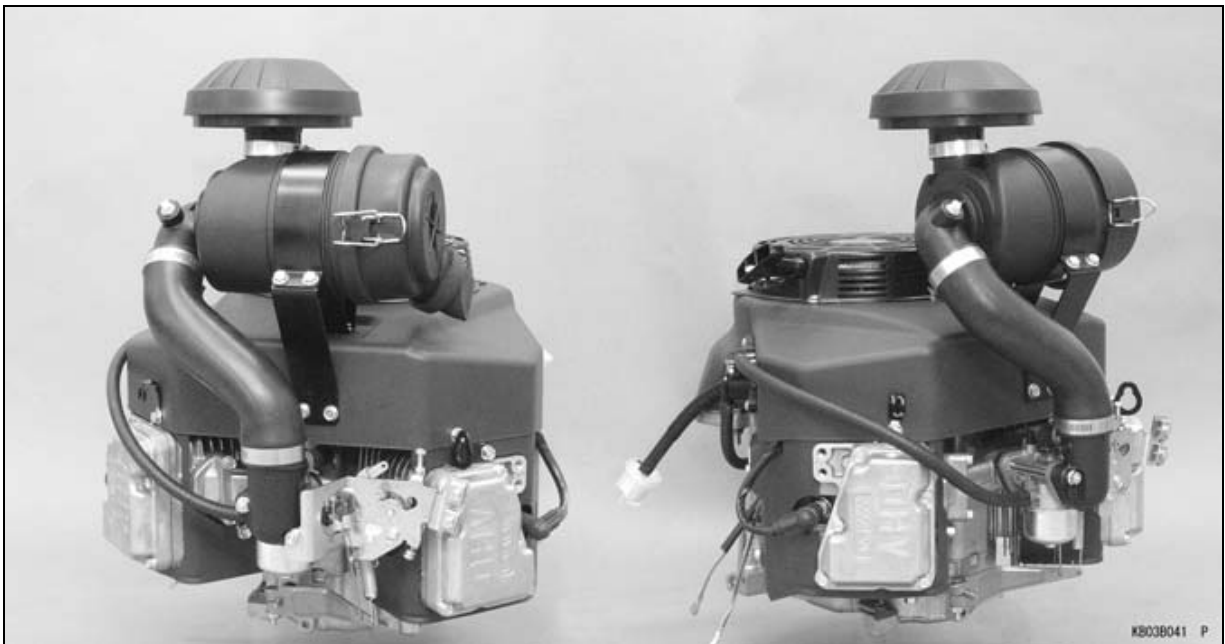

# 1-6 GENERAL INFORMATION

## Model Identification

### FS Models (Electric Starter Model)



### FS Models (Recoil Starter Model)

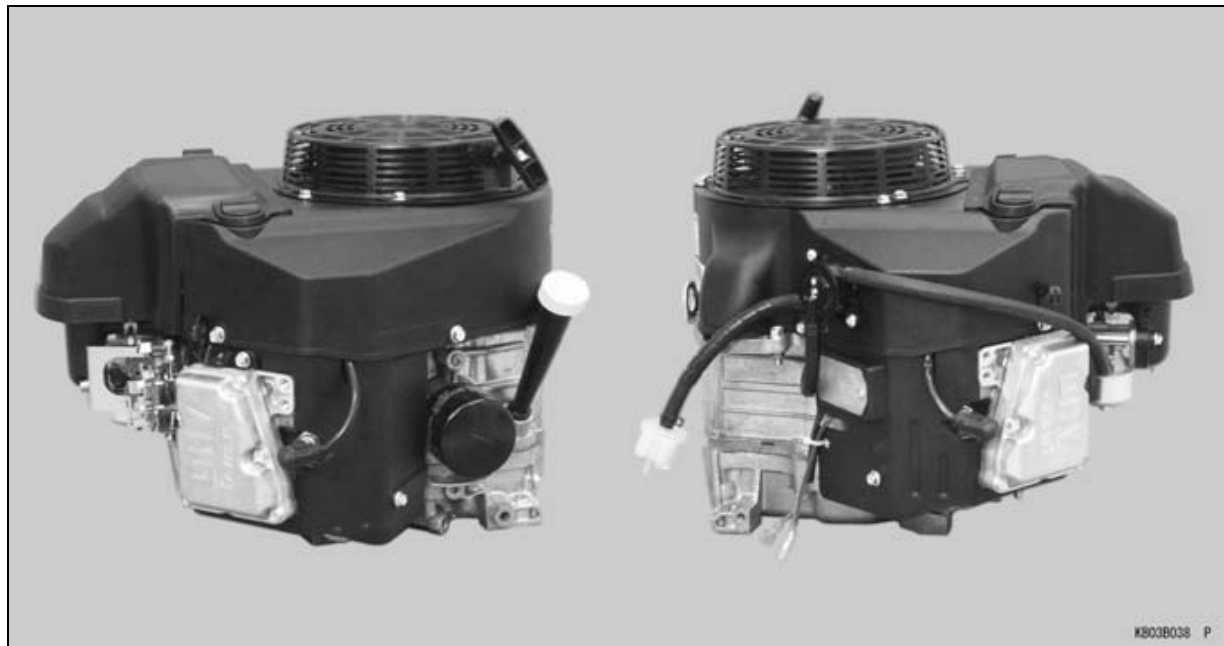

---

**Model Identification**

---

**FR Models**



**Cylinder Number Designation:**

No.1 Cylinder is the left-hand cylinder viewed from the intake pipe.

No.2 Cylinder is the right-hand cylinder viewed from the intake pipe.

## 1-8 GENERAL INFORMATION

### General Specifications

Item	FS481V, FS541V, FS600V, FX481V, FX541V, FX600V, FR541V, FR600V
Type of Engine	Forced air-cooled, vertical shaft, OHV, 4-stroke gasoline engine
Cylinder Layout	90 V-Twin
Bore × Stroke	73 mm × 72 mm (2.87 in. × 2.84 in.)
Piston Displacement	603 cm <sup>3</sup> (36.8 cu in.)
Direction of Rotation	Counterclockwise facing the PTO shaft
Compression Release	Automatic compression release
Low Idle Speed	1 550 r/min (rpm)
High Idle Speed	3 600 r/min (rpm)
Ignition System	Transistorized-flywheel magneto
RFI	Per Canada and U.S.A. requirements
Starting System: FS Models FX Models FR Models	Electric starter/Recoil starter Shift type electric starter/Recoil starter Electric starter
Charging System: Electric Starter Model Recoil Starter Model	12 V - 15 amps with regulator 12 V - 3.6 amp without regulator (optional part)
Spark Plug	NGK BPR4ES
Carburetor	Float type, fixed main jet, internally vented, single barrel
Fuel Pump	Diaphragm type pulse pump
Air Cleaner: FS Models FX and FR Models	Dual stage element, dry type Single stage element, dry type
Governor	Flyweight all speed governor
Lubrication System Oil Filter Oil Capacity (when engine is completely dry)	Pressure feed by positive displacement pump Cartridge type full flow filter 2.0 L (2.1 US qt)
Cooling System	Forced air cooling by fan
Dimensions (L × W × H): FS and FR Models FX Models	486 mm × 429 mm × 362 mm (19.1 in. × 16.9 in. × 14.3 in.) 468 mm × 429 mm × 543 mm (18.4 in. × 16.9 in. × 21.4 in.)
Dry Weight (without muffler): FS and FR Models FX Models	36.7 kg (80.9 lb) 40.7 kg (89.7 lb)

Specifications are subject to change without notice.

# Periodic Maintenance

## Table of Contents

Periodic Maintenance Chart .....	2-2
Torque and Locking Agent.....	2-3
Specifications .....	2-6
Special Tools .....	2-7
Periodic Maintenance Procedures.....	2-8
Fuel System.....	2-8
Low Idle Speed Adjustment .....	2-8
High Idle Speed Adjustment .....	2-8
Fuel System Cleanliness Inspection .....	2-9
Element Cleaning and Inspection .....	2-10
Engine Top End .....	2-11
Cylinder Head Cleaning.....	2-11
Valve Clearance Inspection .....	2-11
Valve Clearance Adjustment.....	2-12
Valve Seat Inspection .....	2-12
Valve Seat Repair .....	2-13
Lubrication System .....	2-16
Engine Oil Level Inspection .....	2-16
Engine Oil Change.....	2-16
Oil Filter Replacement .....	2-17
Electrical System .....	2-17
Spark Plug Cleaning and Inspection.....	2-17
Spark Plug Gap Inspection .....	2-17

## 2-2 PERIODIC MAINTENANCE

### Periodic Maintenance Chart

To ensure satisfactory operation over an extended period of time, any engine requires normal maintenance regular intervals. The Periodic Maintenance Chart below shows periodic inspection and maintenance items and suitable intervals. The bullet mark (●) designates that the corresponding item should be performed at that interval.

Some adjustments require the use of special tools or other equipment. An electronic tachometer will facilitate setting idle and running speeds.

OPERATION	INTERVAL						
	Daily	First 8 hr.	Every 25 hr.	Every 100 hr.	Every 200 hr.	Every 250 hr.	Every 300 hr.
Check or clean air intake screen (1)	●						
Check and add engine oil	●						
Check for fuel and oil leakage	●						
Check for loose or lost nuts and screws	●						
Check battery electrolyte level	●						
Replace air cleaner primary element (Heavy Duty Air Cleaner) (FX Models) (1)						●	
Clean air cleaner foam element (FS Models) (1)			●				
Clean air cleaner paper element (FS and FR Models) (1)				●			
Replace air cleaner paper element (FS and FR Models) (1)					●		
Clean dust and dirt from cylinder and cylinder head fins (1)				●			
Tighten nuts and screws				●			
Change engine oil		●		●			
Clean and re-gap spark plugs				●			
Change oil filter					●		
◆Check and adjust valve clearance							●
◆Clean and lap valve seating surface							●
◆Clean combustion chambers							●

(1): Service more frequently under dusty conditions.

◆: These items must be performed with the proper tools. See your authorized Kawasaki Engine Dealer for service, unless you have the proper equipment and mechanical proficiency.

**Torque and Locking Agent**

The following tables list the tightening torque for the major fasteners and the parts requiring use of a non-permanent locking agent or liquid gasket.

Letters used in the "Remarks" column mean:

EO: Apply oil to the threads.

L: Apply a non-permanent locking agent to the threads.

R: Replacement Parts

S: Tighten the fasteners following the specified sequence.

Fastener	Torque			Remarks
	N·m	kgf·m	ft·lb	
<b>Fuel System</b>				
Carburetor and Intake Pipe Mounting Nut	5.9	0.60	52 in·lb	
Control Panel and Intake Pipe Mounting Nut	5.9	0.60	52 in·lb	
Control Panel Mounting Bolt (FS and FX Models)	5.9	0.60	52 in·lb	
Governor Arm Clamp Nut	9.8	1.0	87 in·lb	
Governor Shaft Plate Screws	2.0	0.20	18 in·lb	
Intake Manifold Mounting Bolts (FS and FX Models)	5.9	0.60	52 in·lb	S
Intake Manifold Mounting Bolts (FR Models)	8.8	0.90	78 in·lb	S
Throttle Valve Screws	0.68	0.069	6.0 in·lb	L
<b>FX Models</b>				
Air Cleaner Bracket Mounting Bolts	5.9	0.60	52 in·lb	
Air Cleaner Holder Bracket Bolts	5.9	0.60	52 in·lb	
<b>Electric Starter Model</b>				
Main Jet	1.7	0.17	15 in·lb	
Solenoid Valve	4.5	0.46	40 in·lb	
<b>Recoil Starter Model</b>				
Main Jet	2.3	0.23	20 in·lb	
Float Chamber Mounting Screw	4.5	0.46	40 in·lb	
<b>Cooling System</b>				
<b>FX Models</b>				
Engine Shroud Bolts	5.9	0.60	52 in·lb	
Fan Housing Bolts	5.9	0.60	52 in·lb	
<b>FS and FR Models</b>				
Engine Shroud Bolts	8.8	0.90	78 in·lb	
Fan Housing Bolts	8.8	0.90	78 in·lb	
<b>Electric Starter Model</b>				
Cooling Fan Mounting Bolts	8.8	0.90	78 in·lb	
Cooling Fan Screen Screws	3.0	0.31	27 in·lb	
<b>Electric Starter Model (FX Models)</b>				
Guard Mounting Bolts	5.9	0.60	52 in·lb	
<b>Recoil Starter Model</b>				
Cooling Fan Plate Mounting Bolts	5.9	0.60	52 in·lb	
Flywheel Bolt	56	5.7	41	
<b>Engine Top End</b>				
Connecting Rod Big End Cap Bolts	9.8	1.0	87 in·lb	EO

## 2-4 PERIODIC MAINTENANCE

### Torque and Locking Agent

Fastener	Torque			Remarks
	N·m	kgf·m	ft·lb	
Cylinder Head Bolts (L = 50 mm)	27.4	2.8	20	S
Cylinder Head Bolts (L = 70 mm)	27.4	2.8	20	S
Lift Hook Bolt	5.9	0.60	52 in·lb	
Rocker Arm Bracket Bolts	14.7	1.5	11	L
Rocker Cover Bolts	5.9	0.60	52 in·lb	S
Spark Plugs	22	2.2	16	
Valve Clearance Adjusting Locknuts	11	1.1	97 in·lb	
<b>Lubrication System</b>				
Engine Oil Drain Plug	6.9	0.70	61 in·lb	
Oil Filler Mounting Bolt	8.8	0.90	78 in·lb	
Oil Filter	11.8	1.2	104 in·lb	R
Oil Pump Cover Plate Bolts	5.9	0.60	52 in·lb	
<b>Camshaft/Crankshaft</b>				
Breather Chamber Cover Bolts	5.9	0.60	52 in·lb	
Breather Valve Mounting Screw	2.0	0.20	18 in·lb	
Connecting Rod Big End Cap Bolts	9.8	1.0	87 in·lb	EO
Crankcase Cover Bolts	27.4	2.8	20	S
Crankcase Cover Oil Passage Plugs	3.9	0.40	35 in·lb	L
Crankcase Oil Passage Plugs	3.9	0.40	35 in·lb	L
<b>Starter System</b>				
<b>Electric Starter Model</b>				
Starter Motor Mounting Bolts	19.6	2.0	14	
<b>Electric Starter Model (FS Models)</b>				
Starter Motor Through Bolts	3.95	0.40	35 in·lb	
<b>Electric Starter Model (FR Models)</b>				
Armature Shaft Nut	10.3	1.05	91 in·lb	
Starter Motor Through Bolts	5.88	0.60	52 in·lb	
<b>Recoil Starter Model</b>				
Recoil Starter Mounting Bolts	5.9	0.60	52 in·lb	
Recoil Starter Retainer Screw	5.9	0.60	52 in·lb	L
Starter Motor Plate Mounting Bolts	19.6	2.0	14	
<b>Electrical System</b>				
Flywheel Bolt	56	5.7	41	
Ignition Coil Bolts	5.9	0.60	52 in·lb	
Spark Plugs	22	2.2	16	
Stator Coil Screws	3.4	0.35	30 in·lb	

**Torque and Locking Agent**

The table below, relating tightening torque to thread diameter, lists the basic torque for the bolts and nuts. Use this table for only the bolts and nuts which do not require a specific torque value. All of the values are for use with dry solvent-cleaned threads.

**Basic Torque for General Fasteners**

Threads Diameter (mm)	Torque		
	N·m	kgf·m	ft·lb
4	2.0	0.20	17 in·lb
5	3.4	0.35	30 in·lb
6	5.9	0.60	52 in·lb
8	15	1.5	11
10	20	2.0	15

## 2-6 PERIODIC MAINTENANCE

### Specifications

Item	Standard
<b>Fuel System</b> Idle Speed (1): Low Idle Speed (Carburetor idle rpm) Low Idle Speed (Governor idle rpm) High Idle Speed Air Cleaner: Type: FS Models FX and FR Models Pre-cleaner: FS Models FX Models FR Models Second-stage cleaner: FS Models	1 450 r/min (rpm) 1 550 r/min (rpm) 3 600 r/min (rpm)  Dual stage filtration system Single stage filtration system  Foam element Paper element Paper element  Paper element
<b>Engine Top End</b> Valve Clearance: Intake, Exhaust Valve Seating Surface Angle: Intake, Exhaust Valve Seating Surface Width: Intake Exhaust	0.10 ~ 0.15 mm (0.004 ~ 0.006 in.)  45°  0.8 ~ 1.4 mm (0.031 ~ 0.055 in.) 0.8 ~ 1.4 mm (0.031 ~ 0.055 in.)
<b>Lubrication System</b> Engine Oil: Type Viscosity  Capacity  Level	SJ or higher class SAE 40, SAE 30, SAE 10W-30/SAE 10W-40, or SAE 5W-20  1.5 L (1.6 US qt) (When the oil filter is not removed) 1.7 L (1.8 US qt) (When the oil filter is removed)  Operating range [grid area (ADD and FULL)] on dipstick
<b>Electrical System</b> Spark Plug Spark Plug Gap	NGK BPR4ES 0.7 ~ 0.8 mm (0.028 ~ 0.031 in.)

(1) Idle speeds may vary depending on each equipment. Refer to the equipment specification.

Special Tools

Valve Seat Cutter, 45° -  $\phi 27.5$ :  
57001-1114

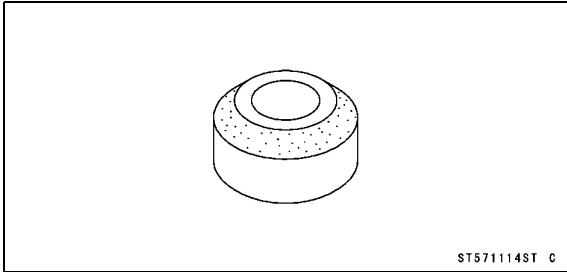

Valve Seat Cutter Holder Bar:  
57001-1128

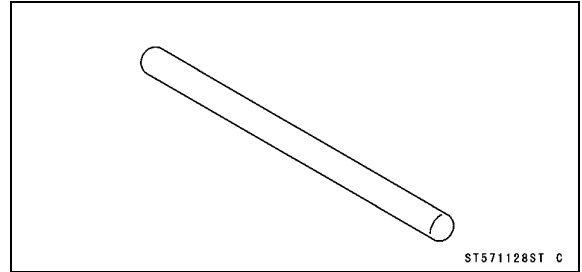

Valve Seat Cutter, 45° -  $\phi 32$ :  
57001-1115

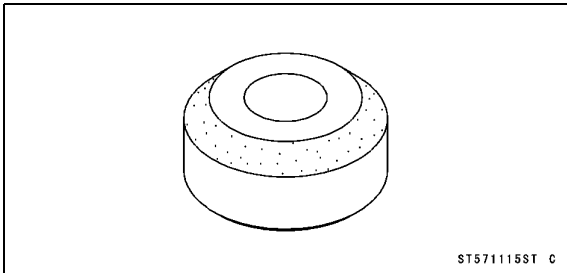

Valve Seat Cutter, 32° -  $\phi 33$ :  
57001-1199

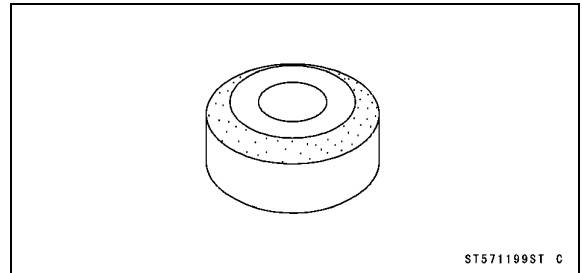

Valve Seat Cutter, 32° -  $\phi 28$ :  
57001-1119

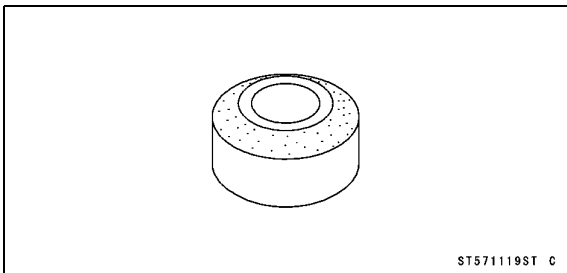

Valve Seat Cutter Holder,  $\phi 6$ :  
57001-1360

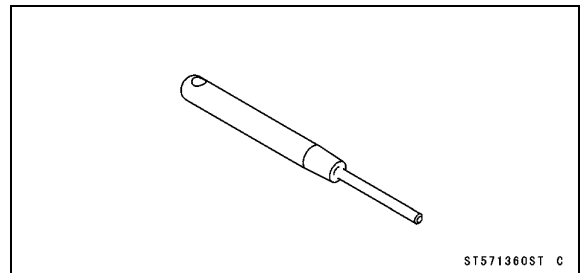

## 2-8 PERIODIC MAINTENANCE

### Periodic Maintenance Procedures

#### Fuel System

##### NOTE

○High and low idle speeds may vary depending on the equipment on which the engine is used. Refer to the equipment specification.

##### Low Idle Speed Adjustment

- Disconnect all possible external loads from the engine.
- Start the engine and warm it up thoroughly.

##### **⚠ WARNING**

**Moving parts can cause severe injury. Keep your hands clear of the moving parts.**

- Move the throttle lever at a dash to the idle position.
- Hold the throttle lever on the carburetor in closed position (turn the governor arm clockwise all the way) and adjust the low idle speed screw [A] until the engine idles at specified speed.

**Low Idle Speed (Carburetor idle rpm)**  
**1 450 r/min (rpm)**

- Release the throttle lever.
- Loosen the locknut [A].
- Adjust the low idle speed set screw [B] on the control plate to obtain the specified governor low idle speed.

**Low Idle Speed (Governor idle rpm)**  
**1 550 r/min (rpm)**

- Tighten the locknut.

##### High Idle Speed Adjustment

##### NOTE

○High idle speed adjustment should be made after the idle speed adjustment is performed.

##### **NOTICE**

**Do not adjust high idle speed with the air cleaner removed.**

- Start and warm up the engine thoroughly.

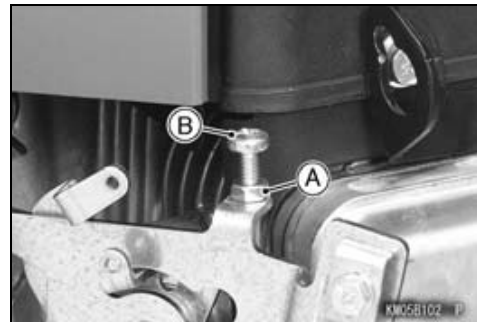
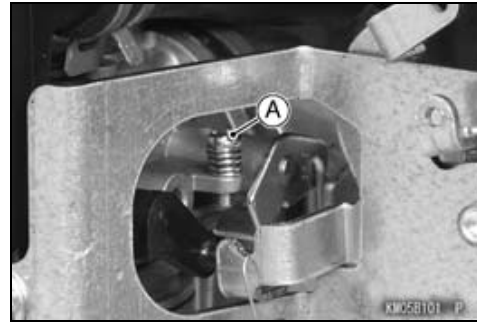

**Periodic Maintenance Procedures**

**⚠ WARNING**

**Moving parts can cause severe injury. Keep your hands clear of the moving parts.**

- Loosen the locknut [A], and unscrew the high idle set screw [B] few turns.
- Move the throttle lever on dash to obtain the specified high idle speed and leave it there.

**High Idle Speed**  
**3 600 r/min (rpm)**

- Turn the high idle set screw so that the end of it just touches the speed control lever [C], and tighten the lock nut.
- Check the idle speed, and readjust the idle speed if necessary.

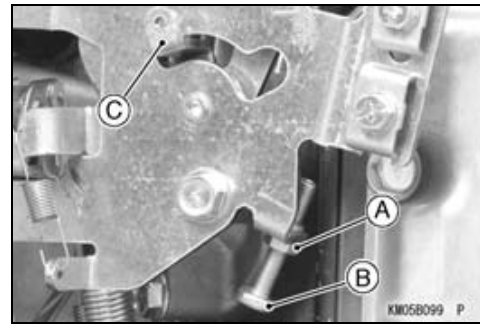

**NOTICE**

**Be sure to make the idle and fast idle speeds respectively correspond to those of the equipment.**

**Fuel System Cleanliness Inspection**

**⚠ WARNING**

**Gasoline is extremely flammable and can be explosive under certain conditions. Turn the engine switch off. Do not smoke. Make sure the area is well ventilated and free from any source of flame or sparks; this includes any appliance with a pilot light.**

**Electric Starter Model**

- Place a suitable container under the carburetor.
- Remove:
  - Solenoid Valve Connector [A]
  - Solenoid Valve [B]
  - Float Chamber [C] and Gasket
- Check if water or dirt has accumulated in the carburetor.
- Install the removed parts (see appropriate chapters).

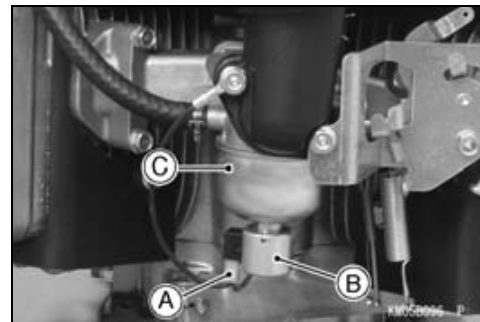

**Recoil Starter Model**

- Place a suitable container under the carburetor.
- Remove:
  - Screw [A]
  - Float Chamber [B] and gasket
- Check if water or dirt has accumulated in the carburetor.
- Install the removed parts (see appropriate chapters).

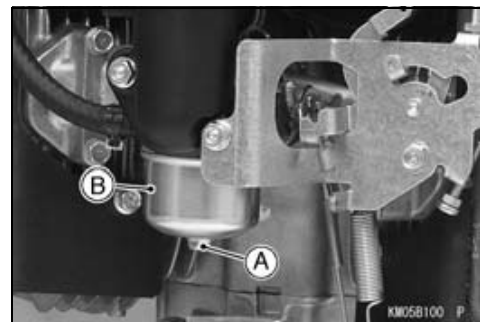

★ If any water or dirt is found, clean the carburetor (see Carburetor Cleaning in the Fuel System chapter) and fuel tank. And check the fuel filter (see Fuel Filter Inspection in the Fuel System chapter).

## 2-10 PERIODIC MAINTENANCE

### Periodic Maintenance Procedures

#### ***Element Cleaning and Inspection***

Air cleaner elements are not recommended to be cleaned, and each air cleaner element should be replaced with new ones at the maintenance time as shown in the maintenance chart.

#### **NOTE**

○ *Operating in dusty condition may require more frequent maintenance than above.*

#### **FX Models**

- Remove the element (see Element Removal in the Fuel System chapter).
- Replace the primary element [A] every 250 hrs.

#### **NOTICE**

**Do not wash air cleaner element. Do not oil air cleaner element. Do not use pressurized air to clean air cleaner element.**

#### **FS Models**

- Remove the foam and paper elements (see Air Cleaner Element Removal).
- Clean the foam element [A] in a bath of detergent and water, and let the element air-dry thoroughly.
- Clean the paper element [B] by tapping it gently on a flat surface to remove dust. If the element is very dirty, replace it with a new one.

#### **FR Models**

- Remove the element (see Air Cleaner Element Removal).
- Clean the paper element [A] by tapping it gently on a flat surface to remove dust. If the element is very dirty, replace it with a new one.

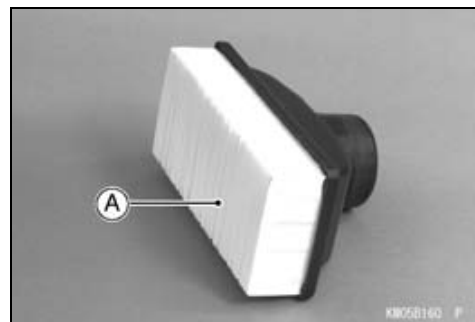
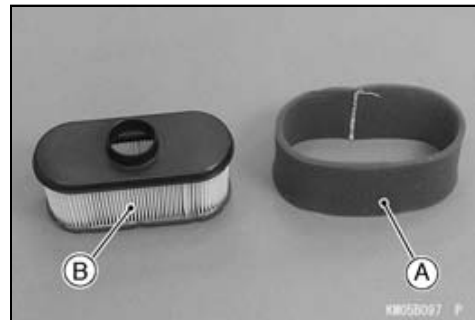
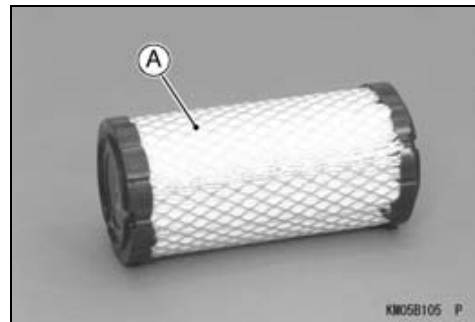

**Periodic Maintenance Procedures**

**Engine Top End**

**Cylinder Head Cleaning**

- Scrape the carbon deposits from the cylinder head and the exhaust port with a suitable tool [A].
- To avoid gouging, use scrapers that are made of a material that will not cause damage.
- Clean the head in a bath of high flash-point solvent and dry it with compressed air.

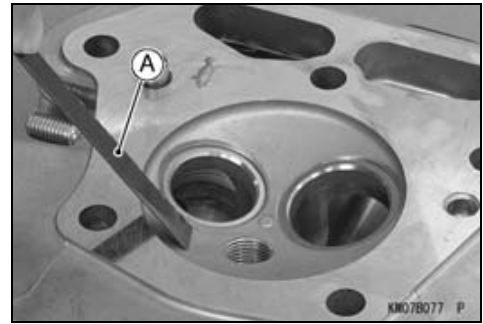

**⚠ WARNING**

**Gasoline and low flash-point solvents can be flammable and/or explosive and cause severe burns. Clean the cylinder head in a well-ventilated area, and take care that there are no sparks or flame anywhere near the working area; this includes any appliance with a pilot light. Do not use gasoline or a low flash-point solvent to clean the cylinder head.**

**Valve Clearance Inspection**

**NOTE**

- Valve clearance must be checked when the engine is cold (at room temperature).
- Remove the rocker covers (see Cylinder Head Assembly Removal in the Engine Top End chapter).
- Place the piston at the top dead center (TDC) of the compression stroke by turning the crankshaft clockwise facing the flywheel.

**No.1 Cylinder**

- The left projection [A] on the flywheel is faced with the right leg [B] on the #1 ignition coil [C] as shown in the figure.
- Check the intake and exhaust valves are closed completely, if not, turn the flywheel one turn (360°) clockwise and face the left projection with the right leg again.

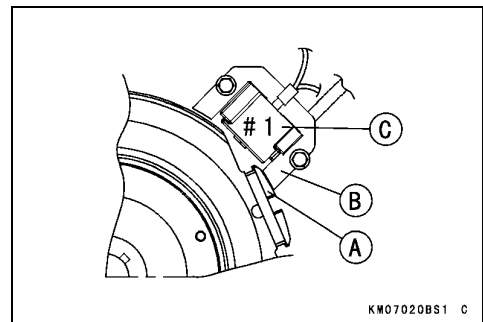

**No.2 Cylinder**

- The left projection [A] on the flywheel is faced with the right leg [B] on the #2 ignition coil [C] as shown in the figure. Follow No.1 cylinder alignment.

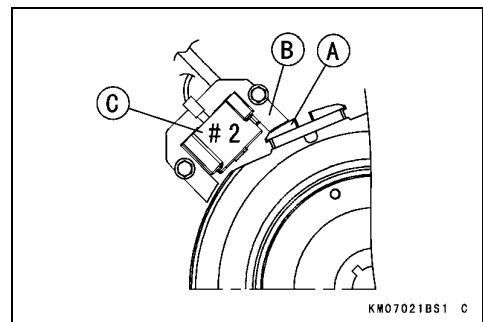

## 2-12 PERIODIC MAINTENANCE

### Periodic Maintenance Procedures

- Then check the valve clearance.
- Using a thickness gauge [A], measure the valve clearance between the rocker arm [B] and the valve stem end.
- ★ If the valve clearance is incorrect, adjust it.

#### Valve Clearance (when cold)

Intake, Exhaust 0.10 ~ 0.15 mm (0.004 ~ 0.006 in.)

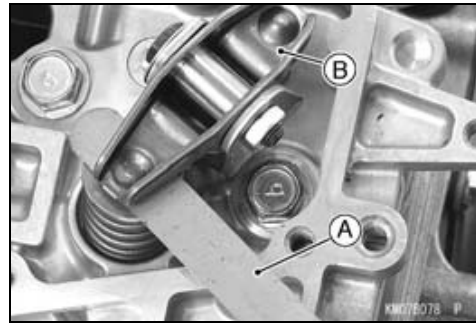

#### Valve Clearance Adjustment

- Since valve repairs change the valve clearance, adjust the valve clearance to the specified.
- Turn the crankshaft in proper direction until the piston is at the TDC of the compression stroke (as described above).
- Loosen the locknut [A] and adjusting bolt [B].
- Insert a 0.10 mm (0.0039 in.) thickness gauge [C] between the rocker arm and valve stem end, and turn the adjusting bolt until the thickness gauge begins to bind between the rocker arm and valve stem end. Sweep the thickness gauge during this adjustment.

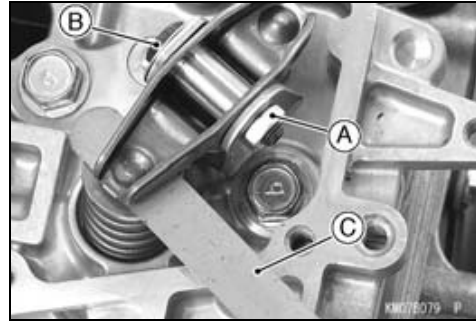

#### Valve Clearance (when cold)

Intake, Exhaust: 0.10 ~ 0.15 mm (0.004 ~ 0.006 in.)

- Holding the adjusting bolt with a spanner [A], tighten the adjusting locknut [B] to the specified torque.

**Torque - Valve Clearance Adjusting Locknuts: 11 N·m (1.1 kgf·m, 87 in·lb)**

- Do not overtighten the valve clearance adjusting locknuts.
- After the valve clearance adjustment, measure the valve clearance again. Readjust the valve clearance if necessary.

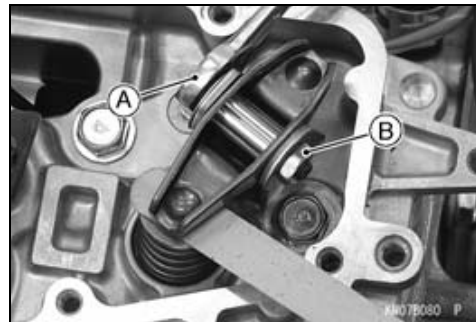

#### Valve Seat Inspection

- Remove the valve (see Valve Mechanism Removal/Installation in the Engine Top End chapter).
- Inspect the valve seats for damage.
- ★ If the seats are warped or distorted beyond reconditioning, replace the cylinder head with a new one.
- Pitted or worn valve seats can be refaced. Lap the valves to the seats after refacing.
- Coat the valve seat with machinist's dye.
- Push the valve into the guide.
- Rotate the valve against the seat with a lapping tool.
- Pull the valve out, and check the seating pattern on the valve head. It must be the correct width [A] and even all the way around.

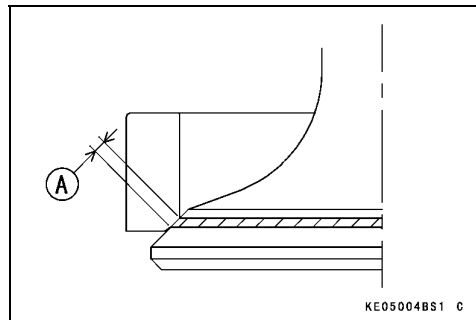

**Periodic Maintenance Procedures**

**NOTE**

○ *The valve stem and guide must be in good condition or this check will not be valid.*

- Good [A]
- Too Wide [B]
- Too Narrow [C]
- Uneven [D]

★ If the valve seating pattern is not correct, repair the seat.

**Valve Seating Surface Width (STD)**

- Exhaust**                0.8 ~ 1.4 mm (0.031 ~ 0.055 in.)
- Intake**                0.8 ~ 1.4 mm (0.031 ~ 0.055 in.)

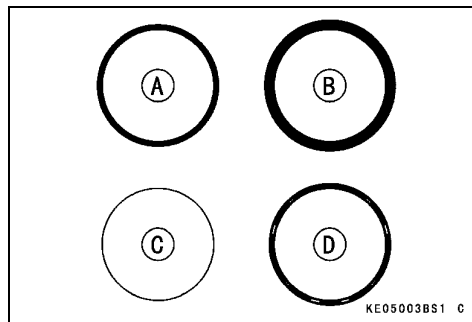

**Valve Seat Repair**

● Follow the manufacture's instructions for use of valve seat cutters.

- Special Tools - Valve Seat Cutter Holder Bar: 57001-1128**
- Valve Seat Cutter Holder, φ6: 57001-1360**

**Exhaust Valve**

- Valve Seat Cutter, 45° - φ27.5: 57001-1114**
- Valve Seat Cutter, 32° - φ28: 57001-1119**

**Intake Valve**

- Valve Seat Cutter, 45° - φ32: 57001-1115**
- Valve Seat Cutter, 32° - φ33: 57001-1199**

★ If the manufacture's instructions are not available, use the following procedure.

**Seat Cutter Operating Cares**

1. This valve seat cutter is designed only for valve seat repair. Therefore the cutter must not be used for other purposes.
2. Do not drop or hit the valve seat cutter, or the diamond particles may fall off.
3. Do not fail to apply engine oil to the valve seat cutter before grinding the seat surface. Also wash off ground particles sticking to the cutter with washing oil.

**NOTE**

○ *Do not use a wire brush to remove the metal particles from the cutter. It will take off the diamond particles.*

4. Setting the valve seat cutter holder [A] in position, operate the cutter [B] with one hand [C]. Do not apply too much force to the diamond portion.

**NOTE**

○ *Prior to grinding, apply engine oil to the cutter, and during the operation wash off any ground particles sticking to the cutter with washing oil.*

5. After use wash the cutter with washing oil and apply a thin layer of engine oil before storing.

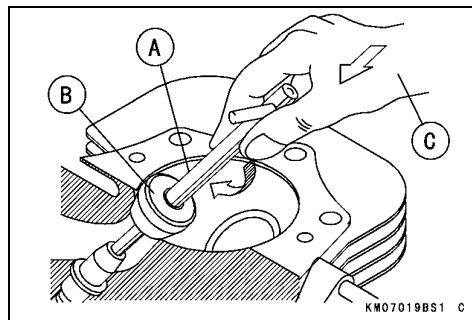

## 2-14 PERIODIC MAINTENANCE

### Periodic Maintenance Procedures

#### Marks Stamped on the Cutter

The marks stamped on the back of the cutter represent the following.

- 32° Cutter angle [A]
- 37.5 Cutter diameter [B]
- KS8B Manufactured lot number

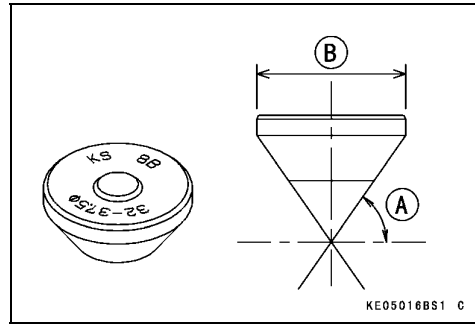

#### Operating Procedures

- Clean the seat area carefully.
- Recondition the valve seats with the valve seat cutters (45°, 32°) and lap the valves.
- Check the seats for good contact all the way around with machinist's dye.
- Measure the seat width [A]. If it is more than the standard width, the seating surface should be refaced.
- ★ If the valve seating pattern is not correct, repair the seat.

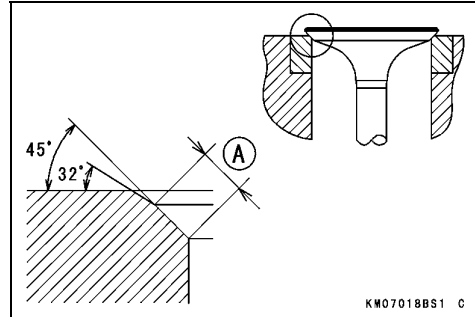

- Coat the seat with machinist's dye.
- Fit a 45° cutter [A] to the holder and slide it into the valve guide.
- Resurface the valve seat with a 45° cutter, removing only enough material to produce a smooth and concentric seat.

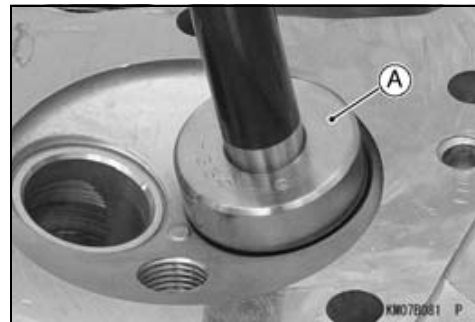

#### NOTICE

**Do not grind the seat too much. Overgrinding will reduce valve clearance by sinking the valve into the head. If the valve sinks too far into the head, it will be impossible to adjust the clearance, and the cylinder head must be replaced. Do not turn the cutter counterclockwise or drop it against the seat, or it will be dulled.**

**Periodic Maintenance Procedures**

- Use a 32° seat cutter [A] to narrow the seat width to the standard width.
- Turn the seat cutter one turn at a time while pressing down very lightly. Check the seat width after each turn.

**NOTICE**

**The 32° cutter removes material very quickly. Check the seat width frequently to prevent over grinding.**

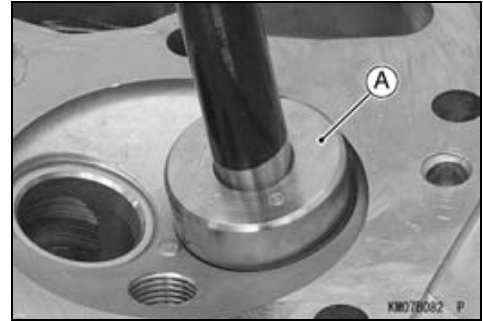

**NOTE**

○ *Keep the seat width as close as possible to the standard width.*

- Make a light contact on the valve seat with the 45° cutter to remove any possible burrs at the edge of the seat.
- After resurfacing the seat, inspect for even valve seating.
- Apply a machinist's dye to the valve face, insert the valve, and snap it closed against the seat several times. The valve surface should show good contact all the way around. Be sure the valve seat is centered on the valve face. The position of the valve in the seat is evident after lapping the valve.

★ If the seat does not make proper contact, lap the valve into seat with a lapper.

- Coat the face of valve sparingly with a fine lapping compound.
- Use the lapping tool [A], to grip top of the valve [B]. Rotate the valve in a circular motion to lap the valve to the seat.
- Lift the valve slightly from the seat every 8 to 10 strokes, continue lapping operation until a uniform ring appears around entire surface of the valve face.

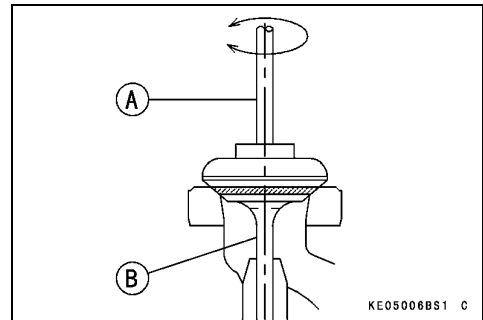

- When lapping is completed, wash all parts in solvent to remove lapping compound. Dry the parts thoroughly.
- Note the position of the lapping mark on the valve face. The lapping mark should appear on or near the center of the valve face.
- When the engine is assembled, be sure to adjust the valve clearances (see Valve Clearance Adjustment).

## 2-16 PERIODIC MAINTENANCE

### Periodic Maintenance Procedures

#### Lubrication System

##### Engine Oil Level Inspection

- Place the engine on a level surface.
- Remove the oil filler cap [A] and wipe its dipstick [B] with a clean cloth.
- Insert the dipstick into tube [C] without screwing it in, then check the oil level.
- The oil level should be the operating range (grid area) [D] on the dipstick.
- ★ If the oil level is “ADD” range [E], add enough engine oil to bring oil level to the operating range.

#### NOTICE

**Do not add more oil above the operating range. Excess oil will cause a smoking condition.**

- Use the same type and make of oil that is already in the engine.

#### NOTE

○ If the engine oil type and make are unknown, use any brand of the specified oil to top up the level in preference to running the engine with the oil level low. Then at your earliest convenience, change the oil completely.

- ★ If the oil level is “FULL” range [F], drain the excess oil by loosening the drain plug.

##### Engine Oil Change

- Change the oil after first 8 hours of operation. Thereafter change oil every 100 hours.
- Start and warm up the engine to drain the oil easily.
- Stop the engine.
- Place the engine on a level surface.
- Place a suitable container under the engine.
- Remove the oil drain plug [A] and drain the oil.

#### WARNING

**Hot oil can cause severe burns. Use caution when draining oil from a hot engine.**

- Replace the O-ring [B] with a new one.
- Apply grease to the O-ring.
- Install the oil drain plug with the O-ring and tighten it.  
Torque - Engine Oil Drain Plug: 6.9 N·m (0.70 kgf·m, 61 in·lb)
- Remove the oil filler cap and pour in the specified type and the amount of oil.

#### Engine Oil:

- Grade:** SJ or higher class
- Viscosity:** SAE40, SAE30, SAE10W-30/SAE10W-40, or SAE5W-20
- Capacity:** [When the oil filter is not removed]  
1.5 L (1.6 US qt)  
[When the oil filter is removed]  
1.7 L (1.8 US qt)

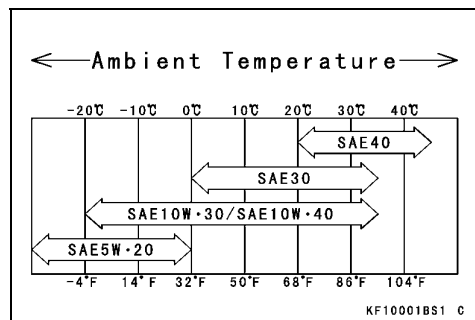
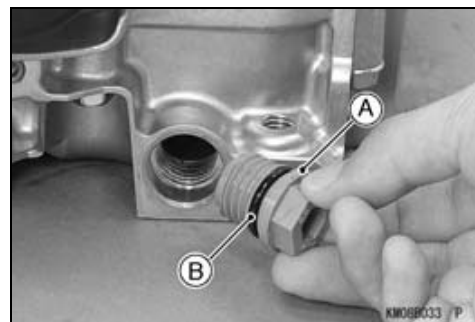
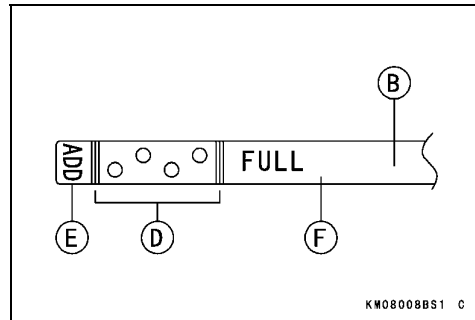
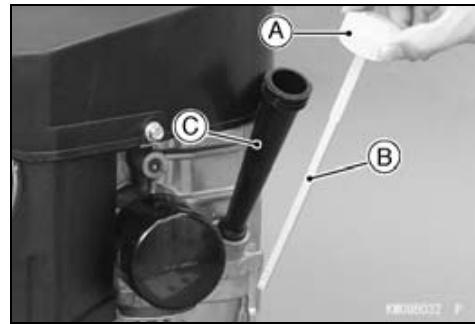

## Periodic Maintenance Procedures

- Check the O-ring [A] on the oil filler cap for damage. Replace the oil filler cap assembly if O-ring is damaged.
- ★ When checking the oil level, do not turn oil filler cap on threads.

### NOTE

- Some increase in oil consumption may be expected when a multi grade engine oil (10W-30/10W-40, 5W-20) is used. Check the oil level more frequently than recommended interval.

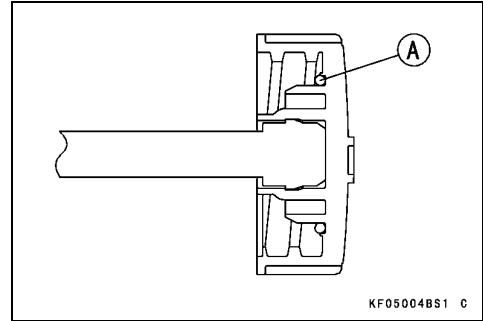

### Oil Filter Replacement

- Drain the engine oil (see Engine Oil Change).
- Using a suitable tool [A], remove the oil filter [B].
- When unscrewing the oil filter, place a suitable container beneath the oil drip tray to receive oil from the oil filter and oil passages in the engine.

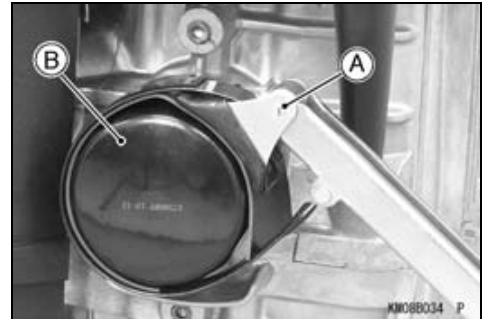

- Replace the oil filter [A] with a new one.
- Apply light film of engine oil to the seal [B].
- Install the oil filter.

**Torque - Oil Filter: 11.8 N·m (1.2 kgf·m, 104 in·lb)**

- Turn the filter until the seal contacts mounting surface [C] of the engine. Then turn the filter BY HAND (S) 3/4 turn.
- Run the engine at slow idle speed 3 minutes.
- While running the engine, check for oil leaks around it.
- Stop the engine and check the oil level (see Engine Oil Level Inspection).

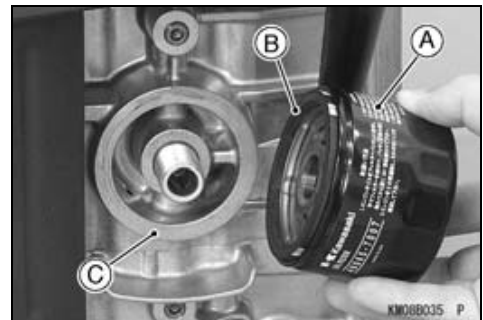

## Electrical System

### Spark Plug Cleaning and Inspection

- Carefully pull the plug cap from the spark plug, and remove the spark plug.
- ★ If the plug is oily or has carbon built up on it, clean the plug using a high flash-point solvent and a wire brush or other suitable tools.
- ★ If the spark plug electrodes are corroded or damaged, or if the insulator is cracked replace the plug with a new one. Use the standard spark plug or its equivalent.

Insulator [A]

Center Electrode [B]

Plug Gap [C]

Side Electrode [D]

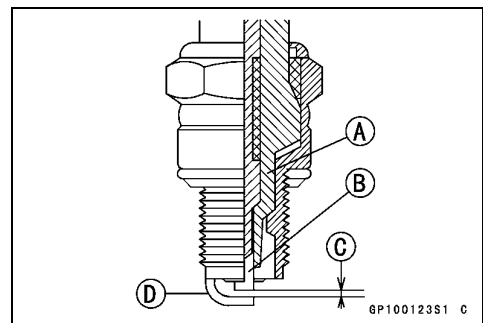

### Spark Plug Gap Inspection

- Measure the gap with a wire-type thickness gauge.
- ★ If the gap is not correct, carefully bend the side electrode with a suitable tool to obtain the correct gap.

### Spark Plug Gap

**Standard: 0.7 ~ 0.8 mm (0.028 ~ 0.031 in.)**



# Fuel System

## Table of Contents

Exploded View .....	3-2
Specifications .....	3-10
Governor Link Mechanism.....	3-12
Control Panel Assembly Removal .....	3-12
Control Panel Assembly Installation .....	3-12
Governor Arm Removal .....	3-13
Governor Arm Installation .....	3-13
Governor Assembly Removal .....	3-14
Governor Assembly Installation .....	3-14
Governor Assembly Inspection .....	3-14
Governor Shaft Removal .....	3-14
Governor Shaft Installation .....	3-15
Carburetor .....	3-16
Fuel and Air Flow .....	3-16
Fuel Shut Off Solenoid Valve .....	3-18
Low Idle Speed Adjustment .....	3-18
High Idle Speed Adjustment .....	3-18
High Altitude Operation.....	3-18
Main Jet Replacement.....	3-18
Fuel System Cleanliness Inspection .....	3-19
Intake Pipe Removal.....	3-20
Intake Pipe Installation.....	3-20
Carburetor Removal.....	3-21
Carburetor Installation.....	3-22
Carburetor Disassembly/Assembly.....	3-23
Carburetor Cleaning.....	3-24
Carburetor Inspection .....	3-25
Fuel Shut Off Solenoid Valve Test .....	3-26
Intake Manifold .....	3-27
Intake Manifold Removal .....	3-27
Intake Manifold Installation .....	3-27
Intake Manifold Inspection .....	3-28
Fuel Pump, Fuel Filter .....	3-29
Fuel Pump Removal .....	3-29
Fuel Pump Installation .....	3-29
Fuel Pump Inspection .....	3-29
Fuel Filter Removal/Installation.....	3-30
Fuel Filter Inspection.....	3-30
Air Cleaner.....	3-31
Element Removal.....	3-31
Element Installation.....	3-32
Element Cleaning and Inspection .....	3-34
Air Cleaner Body and Bracket Removal .....	3-34
Air Cleaner Body and Bracket Installation .....	3-34
Air Cleaner Housing (Cap and Body) Inspection .....	3-35



**Exploded View**

No.	Fastener	Torque			Remarks
		N·m	kgf·m	ft·lb	
1	Air Cleaner Bracket Mounting Bolts	5.9	0.60	52 in·lb	
2	Air Cleaner Holder Bracket Bolts	5.9	0.60	52 in·lb	
3	Carburetor and Intake Pipe Mounting Nut	5.9	0.60	52 in·lb	
4	Control Panel and Intake Pipe Mounting Nut	5.9	0.60	52 in·lb	
5	Float Chamber Mounting Screw (Recoil Starter Model)	4.5	0.46	40 in·lb	
6	Intake Manifold Mounting Bolts	5.9	0.60	52 in·lb	S
7	Main Jet (Electric Starter Model)	1.7	0.17	15 in·lb	
8	Main Jet (Recoil Starter Model)	2.3	0.23	20 in·lb	
9	Solenoid Valve (Electric Starter Model)	4.5	0.46	40 in·lb	
10	Throttle Valve Screws	0.68	0.069	6.0 in·lb	L

11. Recoil Starter Model

L: Apply a non-permanent locking agent.

R: Replacement Parts

S: Tighten the fasteners following the specified sequence.

# 3-4 FUEL SYSTEM

## Exploded View

### FS Models

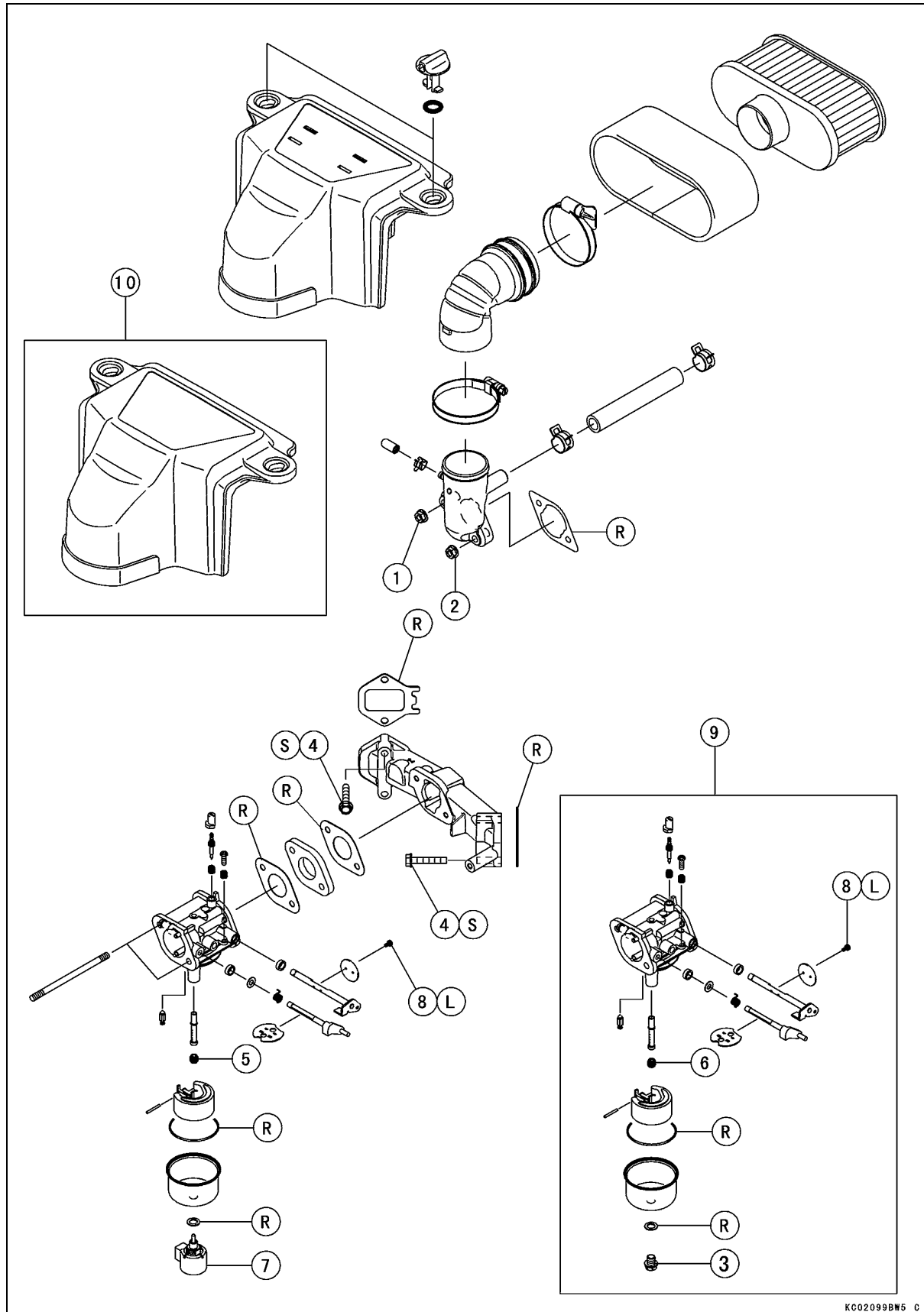

**Exploded View**

No.	Fastener	Torque			Remarks
		N·m	kgf·m	ft·lb	
1	Carburetor and Intake Pipe Mounting Nut	5.9	0.60	52 in·lb	
2	Control Panel and Intake Pipe Mounting Nut	5.9	0.60	52 in·lb	
3	Float Chamber Mounting Screw (Recoil Starter Model)	4.5	0.46	40 in·lb	
4	Intake Manifold Bolts	5.9	0.60	52 in·lb	S
5	Main Jet (Electric Starter Model)	1.7	0.17	15 in·lb	
6	Main Jet (Recoil Starter Model)	2.3	0.23	20 in·lb	
7	Solenoid Valve (Electric Starter Model)	4.5	0.46	40 in·lb	
8	Throttle Valve Screws	0.68	0.069	6.0 in·lb	L

9. Recoil Starter Model

10. FS481/541/600V-AS00 ~ DS00 Models

L: Apply a non-permanent locking agent.

R: Replacement Parts

S: Tighten the fasteners following the specified sequence.

# 3-6 FUEL SYSTEM

## Exploded View

### FR Models

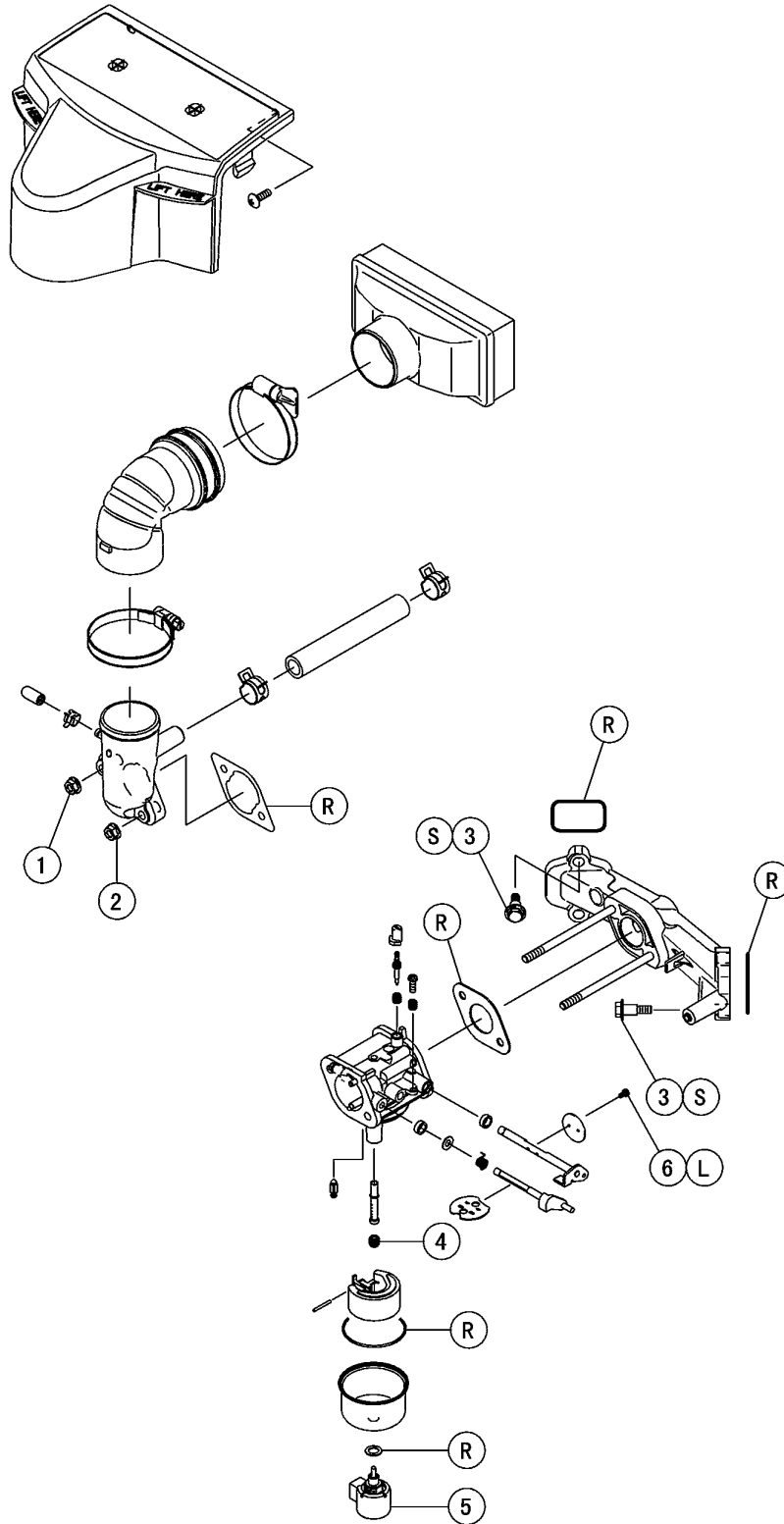

**Exploded View**

No.	Fastener	Torque			Remarks
		N·m	kgf·m	ft·lb	
1	Carburetor and Intake Pipe Mounting Nut	5.9	0.60	52 in·lb	
2	Control Panel and Intake Pipe Mounting Nut	5.9	0.60	52 in·lb	
3	Intake Manifold Bolts	8.8	0.90	78 in·lb	S
4	Main Jet	1.7	0.17	15 in·lb	
5	Solenoid Valve	4.5	0.46	40 in·lb	
6	Throttle Valve Screws	0.68	0.069	6.0 in·lb	L

L: Apply a non-permanent locking agent.

R: Replacement Parts

S: Tighten the fasteners following the specified sequence.

# 3-8 FUEL SYSTEM

## Exploded View

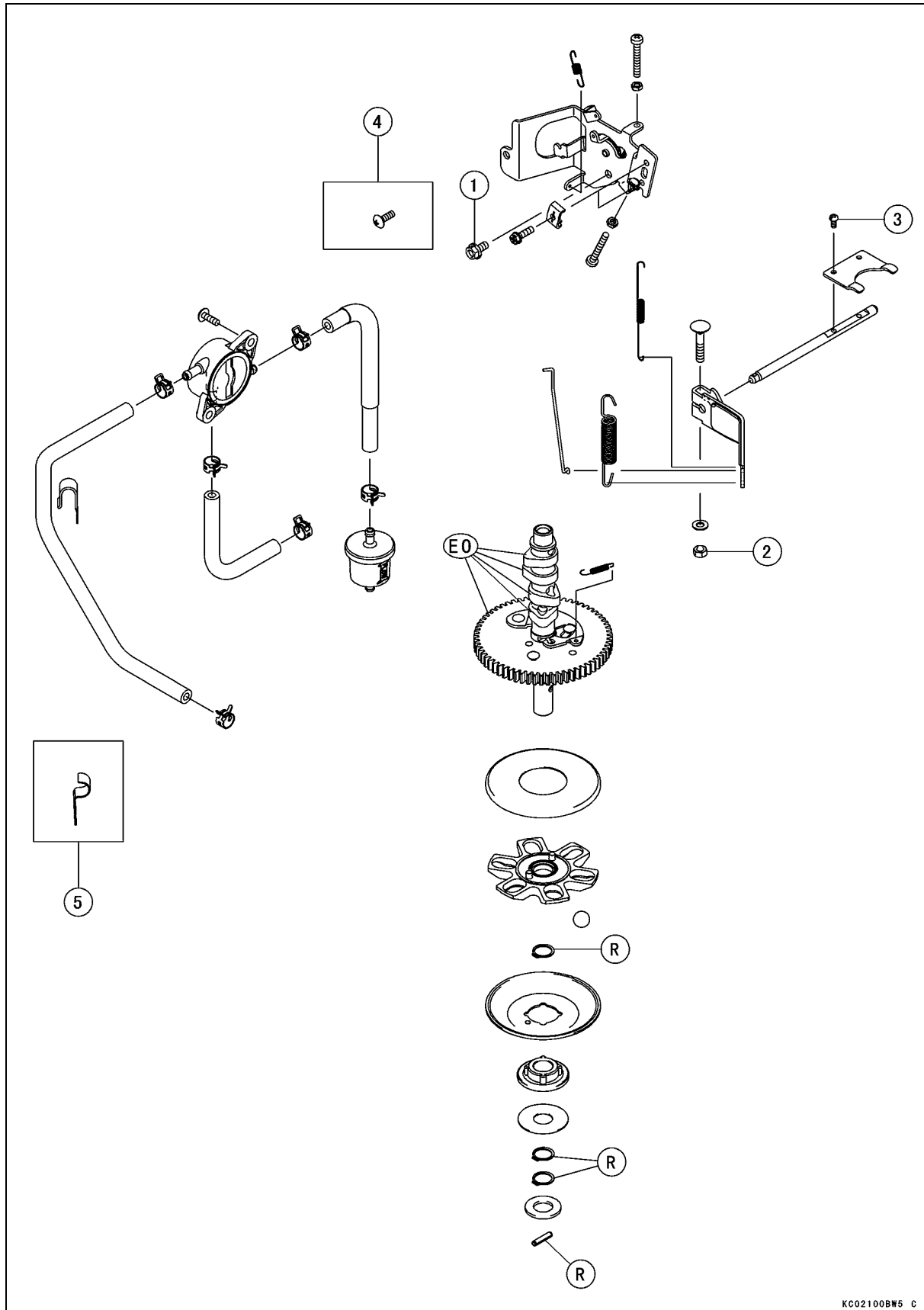

**Exploded View**

No.	Fastener	Torque			Remarks
		N·m	kgf·m	ft·lb	
1	Control Panel Mounting Bolt (FX and FR Models)	5.9	0.60	52 in·lb	
2	Governor Arm Clamp Nut	9.8	1.0	87 in·lb	
3	Governor Shaft Plate Screws	2.0	0.20	18 in·lb	

4. FR Models

5. FS and FR Models

EO: Apply engine oil.

R: Replacement Parts

## 3-10 FUEL SYSTEM

### Specifications

Item	Standard
<p><b>Carburetor Specifications</b></p> <p>Make/ Type:</p> <p>Electric Starter Model:</p> <p>FS481V</p> <p>FS541V</p> <p>FS600V</p> <p>FX481V</p> <p>FX541V</p> <p>FX600V</p> <p>FR541V</p> <p>FR600V</p> <p>Recoil Starter Model:</p> <p>FS481V</p> <p>FS541V</p> <p>FS600V</p> <p>FX481V</p> <p>FX541V</p> <p>FX600V</p> <p>Throttle Bore Diameter</p> <p>Venturi Diameter</p> <p>Main Jet (MJ)</p> <p>Pilot Jet (PJ)</p> <p>Pilot Air Screw Turns out (PS) (Idle Mixture Screw Turns Out)</p> <p>Float Level</p>	<p>Walbro/LMF-28</p> <p>Walbro/LMF-27</p> <p>Walbro/LMF-24</p> <p>Walbro/LMF-30</p> <p>Walbro/LMF-29</p> <p>Walbro/LMF-25</p> <p>Walbro/LMF-41</p> <p>Walbro/LMF-24</p> <p>Walbro/LMF-35</p> <p>Walbro/LMF-33</p> <p>Walbro/LMF-31</p> <p>Walbro/LMF-36</p> <p>Walbro/LMF-34</p> <p>Walbro/LMF-32</p> <p>24 mm (0.94 in.)</p> <p>18 mm (0.71 in.)</p> <p>#102</p> <p>#50</p> <p>1 5/8 ± 1/2</p> <p>Float parallel to carburetor body</p>
<p><b>Idle Speed: (1)</b></p> <p>Low Idle Speed (Carburetor idle rpm)</p> <p>Low Idle Speed (Governor idle rpm)</p> <p>High Idle Speed</p>	<p>1 450 r/min (rpm)</p> <p>1 550 r/min (rpm)</p> <p>3 600 r/min (rpm)</p>
<p><b>Air Cleaner</b></p> <p>Type:</p> <p>FS Models</p> <p>FX and FR Models</p> <p>Pre-cleaner:</p> <p>FS Models</p> <p>FX and FR Models</p> <p>Second-stage cleaner:</p> <p>FS Models</p>	<p>Dual stage filtration system</p> <p>Single stage filtration system</p> <p>Foam element</p> <p>Paper element</p> <p>Paper element</p>
<p><b>Fuel (2)</b></p> <p>Fuel Requirement</p>	<p>Unleaded regular grade gasoline</p>



## 3-12 FUEL SYSTEM

### Governor Link Mechanism

#### Control Panel Assembly Removal

- Remove:
  - Control Panel and Intake Pipe Mounting Nut [A]
  - Control Panel Mounting Bolt [B]

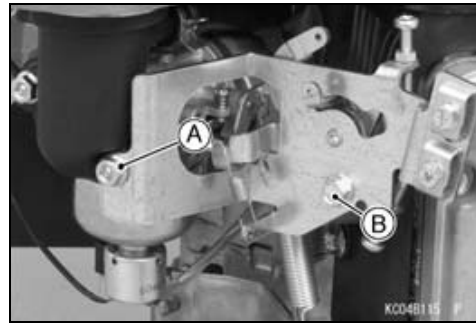

- Remove the control panel assembly [A] while unhooking the governor spring [B] end loop at the panel bracket.

#### NOTE

○ Make sure the governor spring hole position when removing the spring so it can be installed in their original position during assembly.

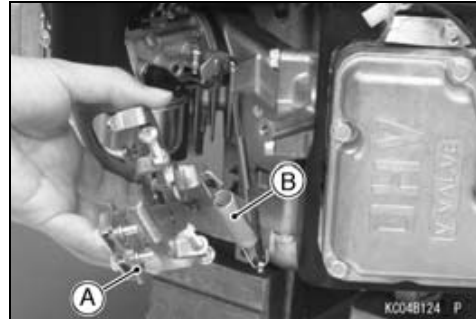

#### Control Panel Assembly Installation

- Before installing the control panel assembly, check to see that the choke lever [A] and engine speed control lever [B] move smoothly in all directions.
- ★ If any part is worn or damaged, replace the control panel assembly with a new one.

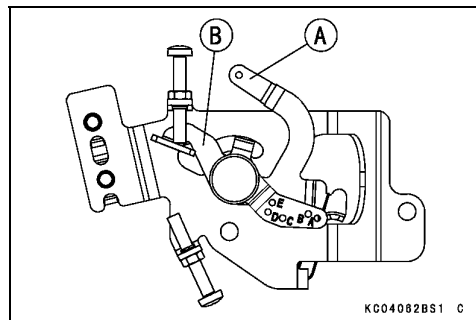

- Hook the governor spring [A] end loop in their original position of the control panel bracket [B].

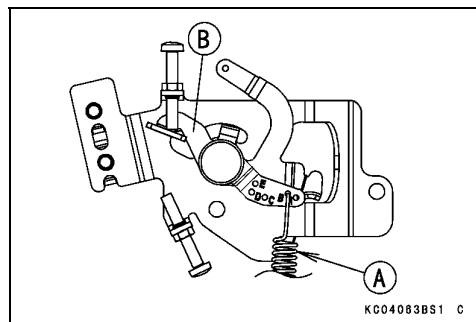

- Install the control panel assembly [A].
- Tighten:
  - Torque - Control Panel Mounting Bolt (FS and FX Models) [B]: 5.9 N·m (0.60 kgf·m, 52 in·lb)
  - Control Panel and Intake Pipe Mounting Nut [C]: 5.9 N·m (0.60 kgf·m, 52 in·lb)
- After installation, adjust the low idle speed and high idle speed to the specifications (see Low/High Idle Speed Adjustment in the Periodic Maintenance chapter).

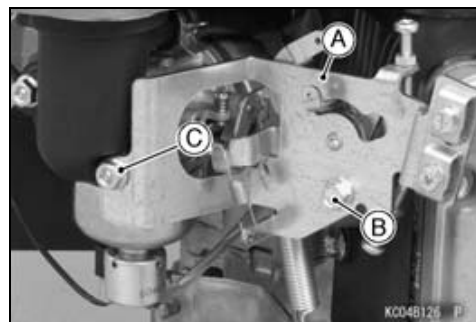

## Governor Link Mechanism

### Governor Arm Removal

- Remove the intake pipe (see Intake Pipe Removal).
- Unhook the throttle link spring [A] and throttle link rod [B] from the throttle shaft lever [C] while pull off the carburetor.

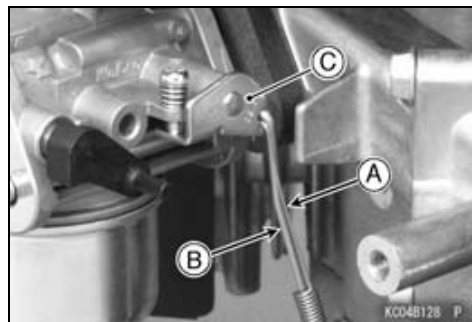

- Loosen the clamp nut [A] and take off the governor arm [B].

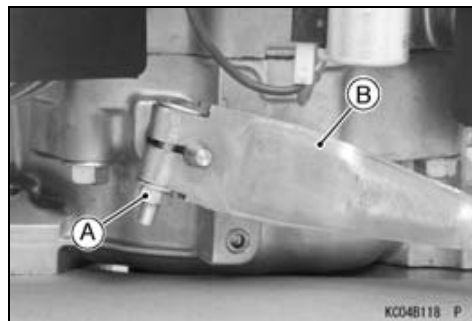

### Governor Arm Installation

- Install the governor arm [A] onto the governor shaft [B] temporarily.
- Be sure the link spring [C] around the throttle link rod [D] is in place and that it pulls the governor arm and throttle lever [E] toward each other.
- Turn the top end of the governor arm counterclockwise [F] to fully open the carburetor [G] throttle valve and hold it there.
- Turn the governor shaft counterclockwise, fully turn the shaft to end of its travel.
- Tighten the clamp nut [H].

**Torque - Governor Arm Clamp Nut: 9.8 N·m (1.0 kgf·m, 87 in·lb)**

6 mm (0.24 in.) [I]

View from Bottom [J]

- Install:  
Intake Pipe (see Intake Pipe Installation)  
Control Panel Assembly (see Control Panel Assembly Installation)

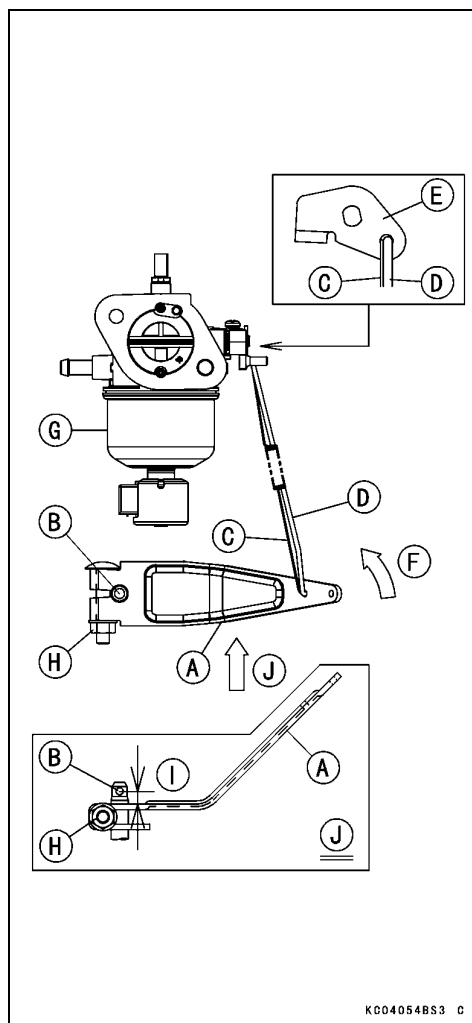

## 3-14 FUEL SYSTEM

### Governor Link Mechanism

#### Governor Assembly Removal

- Remove:
  - Camshaft (see Camshaft, Tappet Removal in the Camshaft/Crankshaft chapter)
  - Pin [A]
  - Washer ( $\phi 30$ ) [B]
  - Snap Rings [C]
  - Washer ( $\phi 42$ ) [D]
  - Sleeve [E]
  - Governor Plate [F]
  - Steel Balls [G]
  - Ball Guide [H]
  - Ball Plate [I]

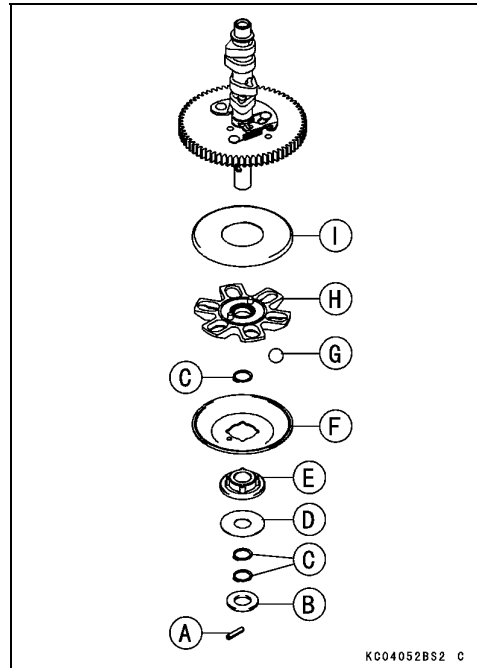

#### Governor Assembly Installation

- Fit the snap ring into the groove securely.
- Turn the governor plate by hand and check that the steel balls and governor plate operate freely.
- Replace the spring pin [A] with a new one.
- Be sure to install the washer [B] and pin.  
2.0 ~ 2.3 mm (0.079 ~ 0.091 in.) [C]

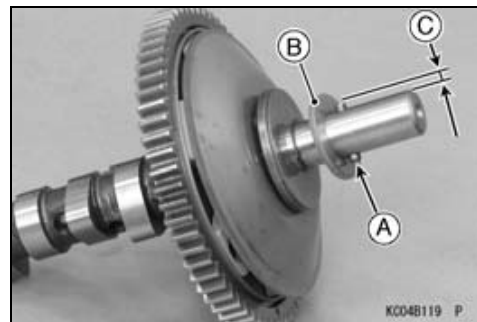

#### Governor Assembly Inspection

- Visually check all governor parts for wear or damage.
- ★ If any parts are worn or damaged, replace them with new ones.

#### Governor Shaft Removal

- Remove the crankcase cover (see Crankcase Cover Removal in the Camshaft/Crankcase chapter).
- Unscrew the governor shaft plate screws [A], and remove the governor shaft plate [B].
- Pull out the governor shaft [C] outside.

#### NOTE

○ Remove the governor shaft only if the replacement of the governor shaft is necessary.

- Replace the oil seal with a new one if the lip shows signs of leakage or it has been damaged (see Crankcase Cover Assembly in the Camshaft/Crankshaft chapter).

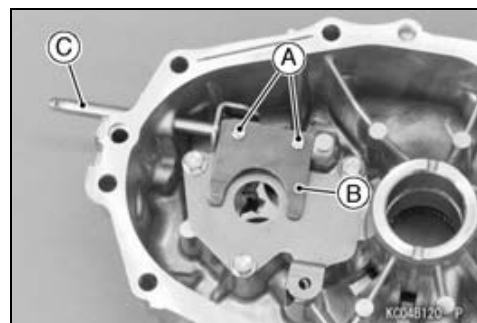

---

## Governor Link Mechanism

---

### ***Governor Shaft Installation***

- Apply engine oil to the governor shaft.
- Insert the governor shaft [A] into the crankcase cover.
- Install the governor shaft plate [B] to the shaft.
- Tighten:
  - Torque - Governor Shaft Plate Screws [C]: 2.0 N·m (0.20 kgf·m, 18 in·lb)
- Check that the governor shaft moves freely in its operating range.

### **NOTE**

- *If the oil seal is removed, oil seal is put on after shaft is installed (see Crankcase Cover Installation in the Camshaft/Crankshaft chapter).*

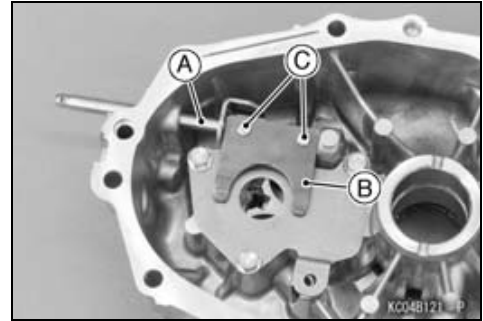

## 3-16 FUEL SYSTEM

### Carburetor

#### Fuel and Air Flow

##### Electric Starter Model

The main system of the carburetor consists of the main jet [A], main nozzle [B], and the main air passage [C] (main air jet [D]). The main system meters fuel to the engine during moderate to heavy load conditions. Fuel flows through the main jet and into the main nozzle, where it is joined by air from the main air passage (main air jet). The resulting mixture flows out the end of the main nozzle into the carburetor bore, where it is atomized by the high speed air flow, and carried into the engine.

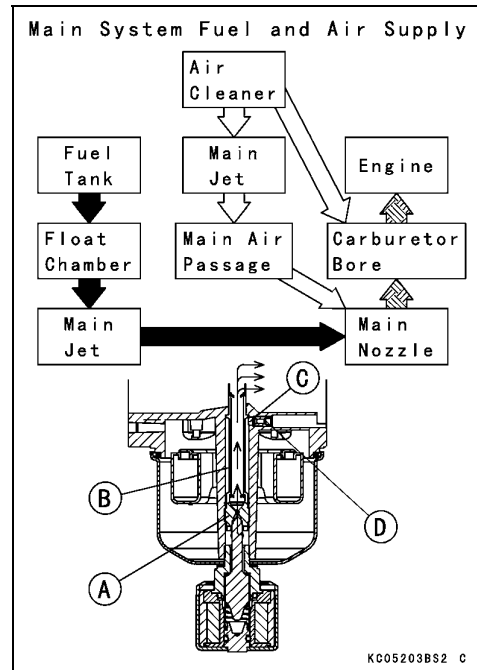

The pilot system includes the pilot jet [E], pilot screw [F] (idle mixture screw), pilot air jet [G], pilot outlet [H], and the bypass holes [I]. The pilot system meters the fuel/air mixture while the engine is idling and running under a light load. Under these conditions there is very little air flow through the carburetor bore; so little that it is not enough to draw fuel through the main system of the carburetor and atomize it. Instead, the fuel is drawn through the pilot system, since the nearly closed throttle valve [J] causes high speed air flow past the pilot outlet and bypass holes (even at low engine speed).

Fuel flow in the pilot system is metered by the pilot jet. Air for better atomization is admitted via the pilot air jet in the mouth of the carburetor. The fuel/air mixture passes into the bore of the carburetor side stream of the throttle valve through the bypass holes and pilot outlet. While the throttle valve is almost closed, it covers the small bypass holes opening into the bore from the pilot system. As the throttle valve begins to open, it uncovers the bypass holes, allowing more fuel/air mixture to flow. The extra flow is needed because the engine starts to run faster as the throttle is opened. The pilot screw controls the amount of fuel/air mixture allowed through the pilot outlet, but does not meter the bypass holes. A moderate amount of air comes in around the throttle valve at idle, so adjusting the pilot screw changes the fuel/air ratio. Turning the pilot screw (idle mixture screw) out (counterclockwise) enriches the mixture; turning it in (clockwise) leans the mixture.

Main Fuel Flow →

Pilot Fuel Flow ⇒

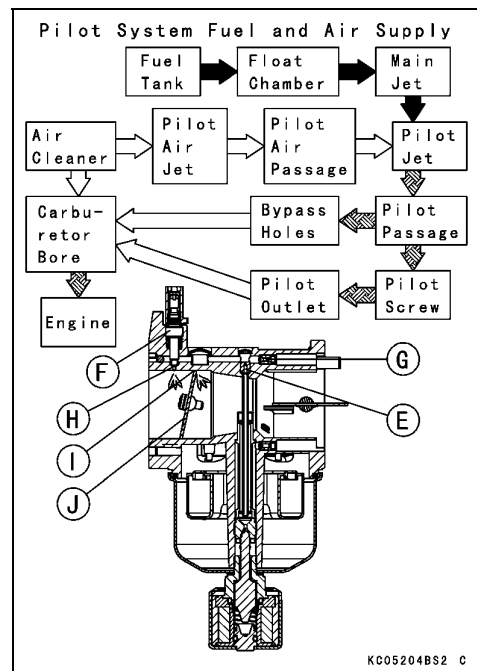

**Carburetor**

**Recoil Starter Model**

The main system of the carburetor consists of the main jet [A], main nozzle [B], and the main air passage [C] (main air jet [D]). The main system meters fuel to the engine during moderate to heavy load conditions. Fuel flows through the main jet and into the main nozzle, where it is joined by air from the main air passage (main air jet). The resulting mixture flows out the end of the main nozzle into the carburetor bore, where it is atomized by the high speed air flow, and carried into the engine.

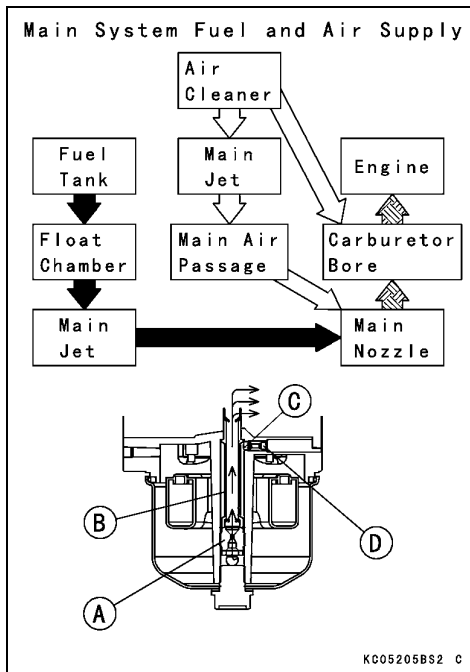

The pilot system includes the pilot jet [E], pilot screw [F] (idle mixture screw), pilot air jet [G], pilot outlet [H], and the bypass holes [I]. The pilot system meters the fuel/air mixture while the engine is idling and running under a light load. Under these conditions there is very little air flow through the carburetor bore; so little that it is not enough to draw fuel through the main system of the carburetor and atomize it. Instead, the fuel is drawn through the pilot system, since the nearly closed throttle valve [J] causes high speed air flow past the pilot outlet and bypass holes (even at low engine speed).

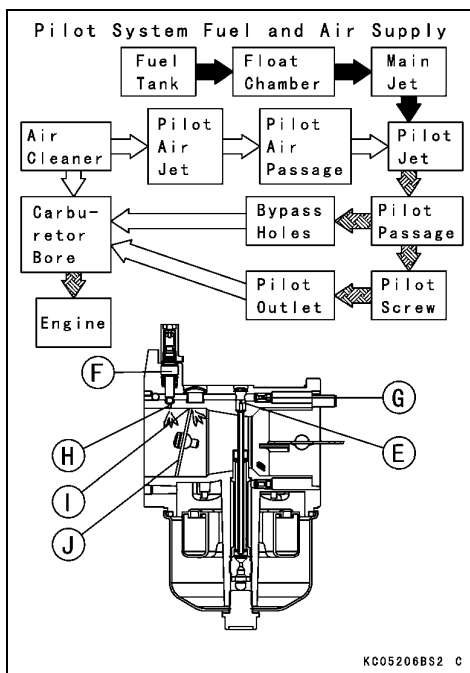

Fuel flow in the pilot system is metered by the pilot jet. Air for better atomization is admitted via the pilot air jet in the mouth of the carburetor. The fuel/air mixture passes into the bore of the carburetor side stream of the throttle valve through the bypass holes and pilot outlet. While the throttle valve is almost closed, it covers the small bypass holes opening into the bore from the pilot system. As the throttle valve begins to open, it uncovers the bypass holes, allowing more fuel/air mixture to flow. The extra flow is needed because the engine starts to run faster as the throttle is opened. The pilot screw controls the amount of fuel/air mixture allowed through the pilot outlet, but does not meter the bypass holes. A moderate amount of air comes in around the throttle valve at idle, so adjusting the pilot screw changes the fuel/air ratio. Turning the pilot screw (idle mixture screw) out (counterclockwise) enriches the mixture; turning it in (clockwise) leans the mixture.

- Main Fuel Flow →
- Pilot Fuel Flow ⇒

## 3-18 FUEL SYSTEM

### Carburetor

#### **Fuel Shut Off Solenoid Valve**

##### **Electric Starter Model**

To avoid after firing when stopping the engine, a solenoid actuated fuel shut off solenoid valve [A] is installed in the carburetor bowl. The valve shuts off the fuel supply to the main jet [B] simultaneously when the switch key turned to the "OFF" position.

The valve opens automatically when the switch key is turned to the "Run" position.

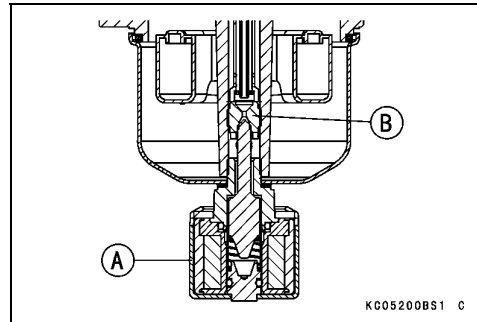

#### **Low Idle Speed Adjustment**

- Refer to the Low Idle Speed Adjustment in the Periodic Maintenance chapter.

#### **High Idle Speed Adjustment**

- Refer to the High Idle Speed Adjustment in the Periodic Maintenance chapter.

#### **High Altitude Operation**

At high altitude, the standard carburetor air-fuel mixture will be excessively rich. Performance will decrease, and fuel consumption will increase. High altitude performance can be improved by installing a smaller diameter main-jet in the carburetor and adjusting the idle speed.

#### **NOTE**

- *The main jet high altitude kits are available if the equipment is to be used in the high altitude. The main jet numbers are stamped on the ends of the main jets.*

#### **High Altitude Main Jet**

Altitude	Main Jet No.
0 ~ 1 000 m (0 ~ 3 000 ft)	#102
1 000 ~ 2 000 m (3 000 ~ 6 000 ft)	#100
2 000 m (6 000 ft) and higher	#98

#### **Main Jet Replacement**

##### **Electric Starter Model**

- Close the fuel shut off valve in the equipment.
- Remove the carburetor (see Carburetor Removal).
- Unscrew the solenoid valve [A] and take off the float chamber [B] and gasket.

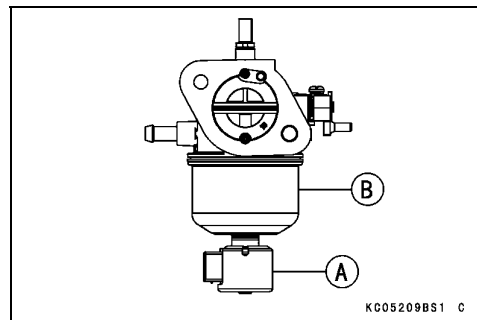

## Carburetor

- Using a properly sized blade screw driver, carefully replace the main jet [A] with a new one for altitude expected.
- Tighten:

**Torque - Main Jet: 1.7 N·m (0.17 kgf·m, 15 in·lb)**

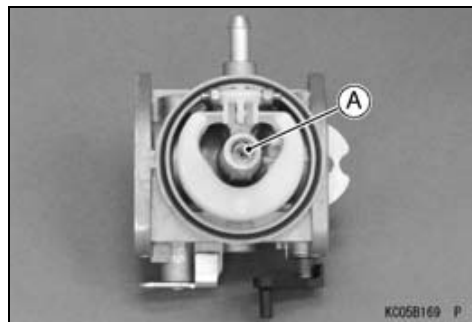

- Replace the float chamber gasket with a new one.
- Install the new gasket and float chamber.
- Tighten the solenoid valve.

**Torque - Solenoid Valve: 4.5 N·m (0.46 kgf·m, 40 in·lb)**

### Recoil Starter Model

- Close the fuel shut off valve in the equipment.
- Remove the carburetor (see Carburetor Removal).
- Unscrew the float chamber mounting screw [A] and take off the float chamber [B] and gasket.

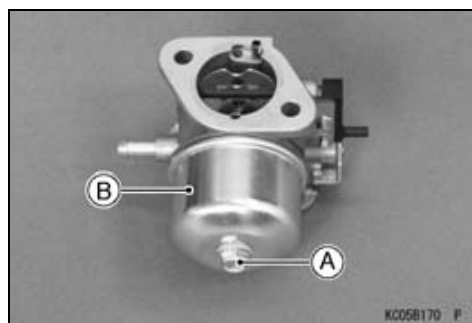

- Using a properly sized blade screw driver, carefully replace the main jet [A] with a new one for altitude expected.
- Tighten:

**Torque - Main Jet: 2.3 N·m (0.23 kgf·m, 20 in·lb)**

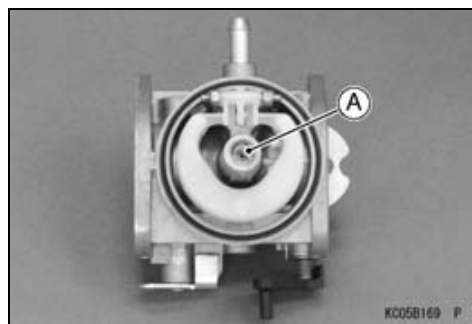

- Replace the float chamber gasket with a new one.
- Install the new gasket and float chamber.
- Tighten the float chamber mounting screw.

**Torque - Float Chamber Mounting Screw: 4.5 N·m (0.46 kgf·m, 40 in·lb)**

### Fuel System Cleanliness Inspection

- Refer to the Fuel System Cleanliness Inspection in the Periodic Maintenance chapter.

## 3-20 FUEL SYSTEM

### Carburetor

#### Intake Pipe Removal

##### Electric Starter Model

- Remove:
  - Element Assembly (see Element Removal)
  - Control Panel Assembly (see Control Panel Assembly Removal)
  - Intake Pipe Mounting Nut [A]
  - Ground Lead [B]
  - Clamp [C]
  - Breather Hose [D]
  - Intake Pipe [E]

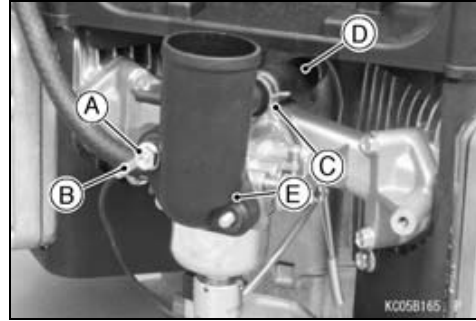

##### Recoil Starter Model

- Remove:
  - Element Assembly (see Element Removal)
  - Control Panel Assembly (see Control Panel Assembly Removal)
  - Intake Pipe Mounting Nut [A]
  - Clamp [B]
  - Breather Hose [C]
  - Intake Pipe [D]

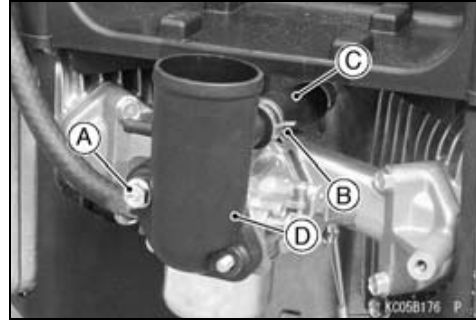

#### Intake Pipe Installation

##### Electric Starter Model

- Replace the gasket [A] with a new one.
- Install:
  - Gasket
  - Intake Pipe [B]
  - Ground Lead [C]
- Tighten:
  - Torque - Carburetor and Intake Pipe Mounting Nut [D]: 5.9 N·m (0.60 kgf·m, 52 in·lb)**
- Connect the breather hose [A] so that the clamp knob [B] faces the downward.
- Install the removed parts (see appropriate chapters).

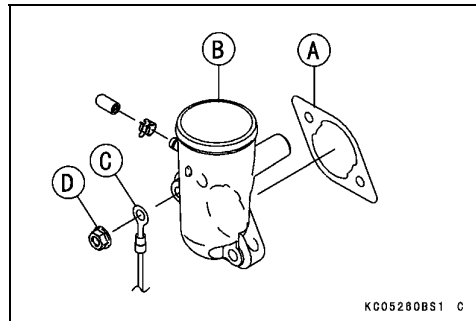

##### Recoil Starter Model

- Replace the gasket [A] with a new one.
- Install:
  - Gasket
  - Intake Pipe [B]
- Tighten:
  - Torque - Carburetor and Intake Pipe Mounting Nut [C]: 5.9 N·m (0.60 kgf·m, 52 in·lb)**

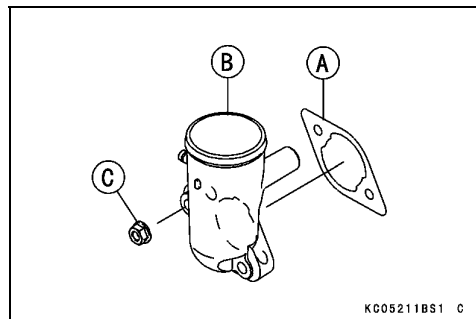

## Carburetor

- Connect the breather hose [A] so that the clamp knob [B] faces the downward.
- Install the removed parts (see appropriate chapters).

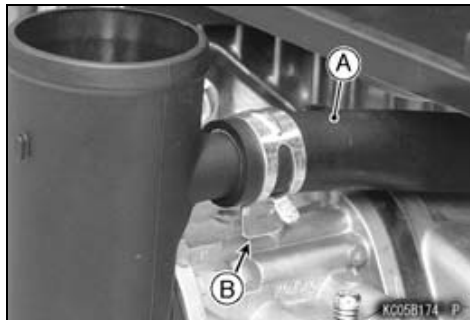

## Carburetor Removal

### **⚠ WARNING**

Gasoline is extremely flammable and can be explosive under certain conditions. Turn the engine switch off. Do not smoke. Make sure the area is well ventilated and free from any source of flame or sparks; this includes any appliance with a pilot light.

- Remove the intake pipe (see Intake Pipe Removal).
- Close the fuel shut off valve in the equipment.
- Remove the clamp [A].
- Disconnect:
  - Fuel Tube [B]
  - Solenoid Valve Connector [C] (Electric Starter Model only)
  - Electric Starter Model [D]
  - Recoil Starter Model [E]

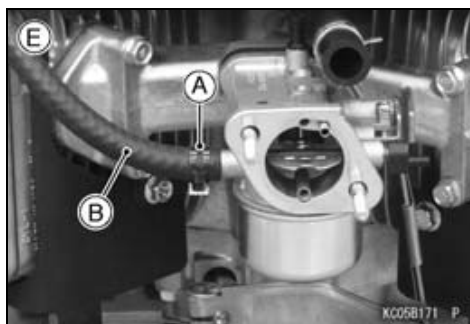
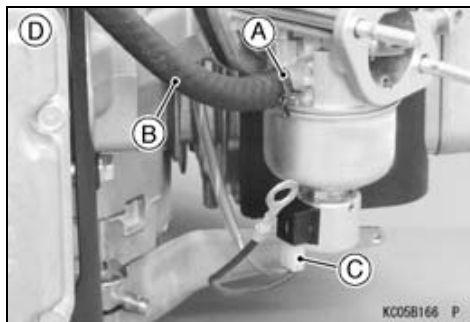

- Unhook the throttle link spring [A] at the throttle shaft lever top end [B] with a long nose plier while pull off the carburetor.
- Unhook the throttle link rod [C] from the top end of the throttle shaft lever while pull off the carburetor.
- Remove the carburetor, gaskets and insulator.

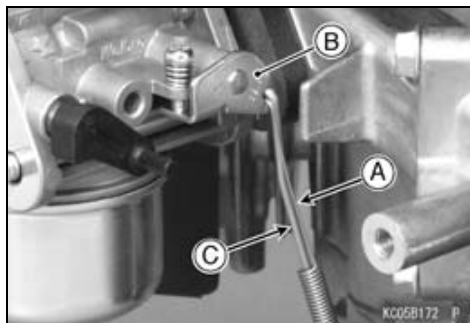

## 3-22 FUEL SYSTEM

### Carburetor

#### Carburetor Installation

- Clean the mating surface of the carburetor and intake manifold.
- Replace the gaskets [A] with new ones.
- Install the insulator [B], carburetor [C] and gaskets sequence as shown in the figure.
- Apply dielectric grease to the solenoid valve connector.
- Connect the solenoid valve connector.
  - Electric Starter Model (FS and FX Models) [D]
  - Electric Starter Model (FR Models) [E]
  - Recoil Starter Model [F]

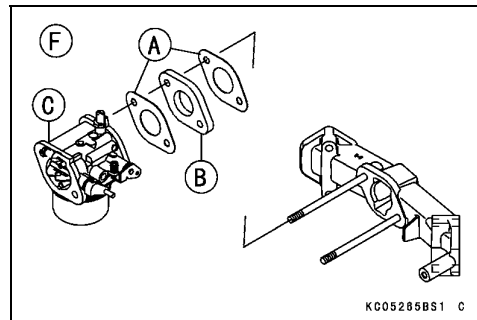
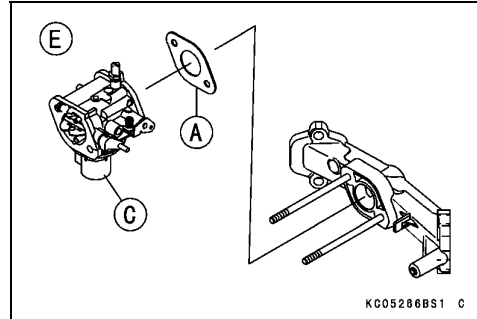
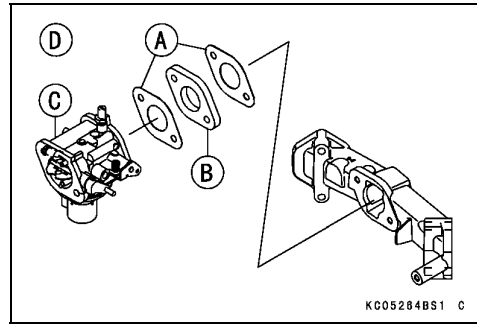

- Install the throttle link rod [A] and spring [B] to the throttle shaft lever [C].

#### NOTE

○ Take care not to bend the throttle link rod during installation.

- Make sure the link spring around the throttle link rod is in place and that it pulls the governor arm and carburetor throttle shaft lever toward each other.
- Install the fuel tube [A] fully so that the clamp knob [B] faces the downward.
- Install the removed parts (see appropriate chapters).
- After installation, adjust the idle speed (see Low/High Idle Speed Adjustment in the Periodic Maintenance chapter).

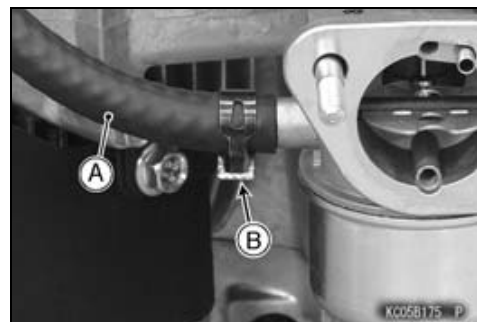
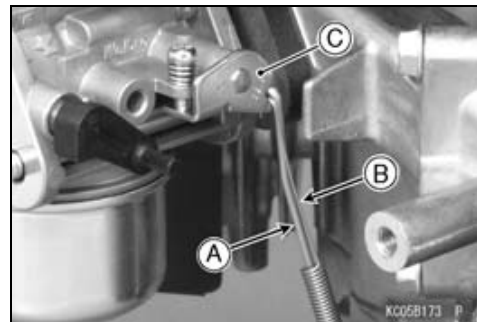

**Carburetor**

**Carburetor Disassembly/Assembly**

- Refer to the illustration shown for disassembly and assembly.
- There are several passage plugs (ball plugs) in the carburetor body. Do not remove.
- Before disassembly, mark the out side of choke and throttle valves for assembling them.
- Install the choke valve and throttle valve on the shaft as the out side mark of them facing out side.
- Drive the float pin into the carburetor body.
- Assemble carburetor parts with recommended tightening torque (see Exploded View).

1. Limiter
2. Pilot Screw
3. Spring
4. Low Idle Speed Screw
5. Spring
6. Screws
7. Throttle Valve
8. Throttle Shaft
9. Dust Seal
10. Choke Valve
11. Choke Shaft
12. Spring
13. Washer
14. Dust Seal
15. Solenoid Valve (Electric Starter Model)
16. Gasket
17. Float Chamber
18. Gasket
19. Float Pin
20. Float
21. Main Jet
22. Main Nozzle
23. Float Valve
24. Screw (Other than Solenoid Valve Type)

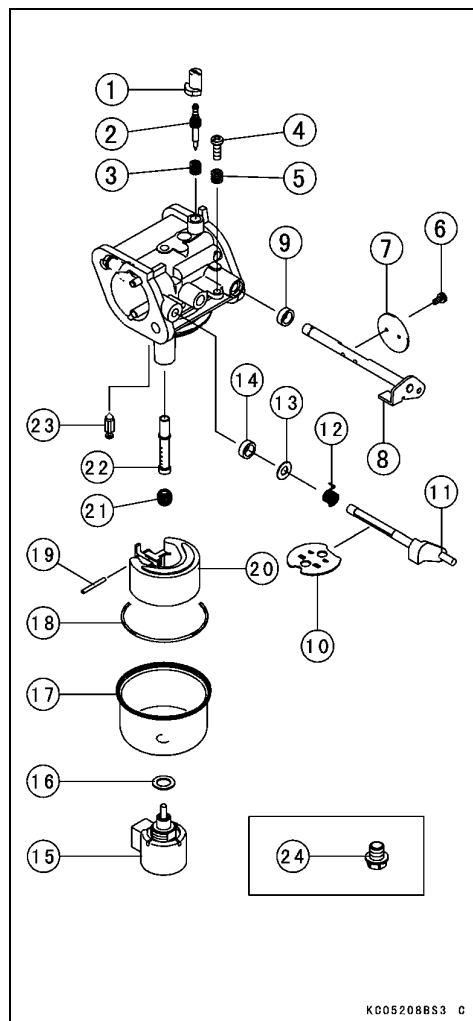

## 3-24 FUEL SYSTEM

### Carburetor

#### *Carburetor Cleaning*

#### **WARNING**

Gasoline and low flash-point solvents can be flammable and/or explosive and cause severe burns. Clean the carburetor in a well-ventilated area, and take care that there are no sparks or flame anywhere near the working area; this includes any appliance with a pilot light. Do not use gasoline or a low flash-point solvent to clean the carburetor.

#### **NOTICE**

Do not use compressed air on an assembled carburetor, or the floats may be crushed by the pressure. Remove as many rubber or plastic parts from the carburetor as possible before cleaning the carburetor with a cleaning solution. This will prevent damage to or deterioration of the parts.

The carburetor body has plastic parts that cannot be removed. Do not use a strong carburetor cleaning solution which could attack these parts; instead, use a mild high flash-point cleaning solution safe for plastic parts.

Do not use wire or any other hard instrument to clean carburetor parts, especially jets, as they may be damaged.

- Disassemble the carburetor (see Carburetor Disassembly/Assembly).
- Immerse all the carburetor metal parts in a carburetor cleaning solution and clean them.
- Rinse the parts in water and dry them with compressed air.
- Do not use rags or paper to dry parts. Lint may plug the holes or passages.
- Blow air through the holes and fuel passages with the compressed air. All holes must be open.
- Assemble the carburetor (see Carburetor Disassembly/Assembly).

**Carburetor**

**Carburetor Inspection**

**⚠ WARNING**

**Gasoline is extremely flammable and can be explosive under certain conditions. Turn the engine switch off. Do not smoke. Make sure the area is well ventilated and free from any source of flame or sparks; this includes any appliance with a pilot light.**

- Inspect the carburetor body for damage. Flange sealing surfaces should be smooth and free of burns and nicks.
- Turn the throttle and choke shafts to check that the throttle and choke butterfly valves move smoothly.
- ★ If the valves do not move smoothly, replace the carburetor body and/or throttle shaft and choke shaft assembly with new ones.
- Check the gasket on the carburetor body.
- ★ If the gasket is not in good condition, replace it with a new one.
- Check the other parts of the carburetor for any wear or damage. Replace the part with a new one if necessary.
- Clean and check the float level as follows.

**NOTICE**

**Do not push down on the float during float level checking.**

- With the float [A] assembly installed onto the carburetor body, hold the carburetor upside down at eye level. Gently support the float with a finger and bring it down slowly so that the float arm tab [B] just touches the float valve [C]. The float lower surface [D] should be parallel with the carburetor body mating surfaces [E].
- ★ If the float position is not correct, replace the float with a new one.
  - Electric Starter Model [F]
  - Recoil Starter Model [G]

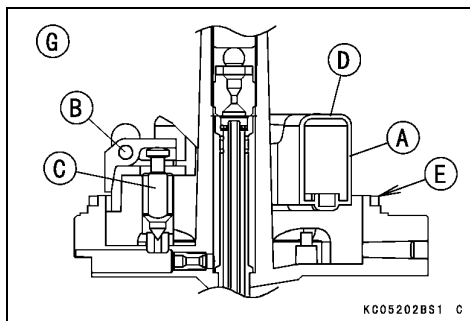
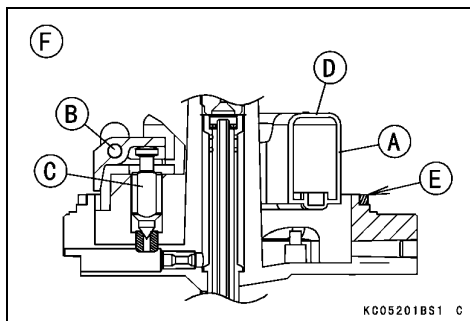

## 3-26 FUEL SYSTEM

### Carburetor

- Inspect the float valve for excessive wear or damage. The tip should be smooth, without any grooves, scratches, or tears. The rod at the other end of the needle should move smoothly when push in and released.

Good [A]

Not Good [B]

- ★ If either the needle or the seat is worn or damaged, replace the float assembly and carburetor body as a set with a new one.

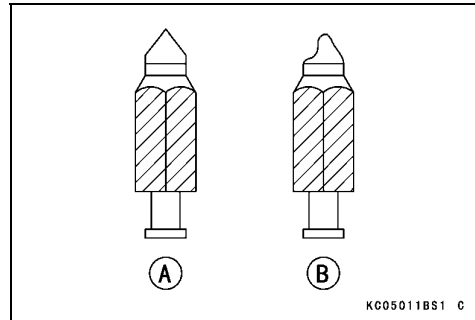

- Inspect the tapered portion [A] of the pilot screw [B] for wear or damage.
- ★ If the pilot screw is worn or damaged on the tapered portion, replace it with a new one.
- Check the spring for weakened condition, replace it with a new one if necessary.

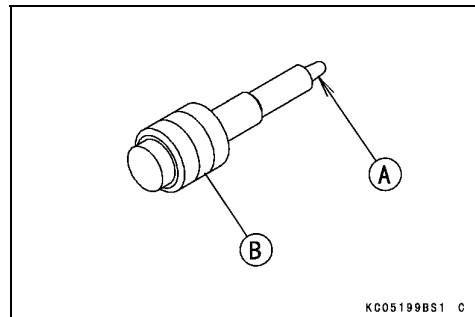

### Fuel Shut Off Solenoid Valve Test

#### Electric Starter Model

- Unscrew the fuel shut off valve [A] and remove it.
- Connect a 12 VDC source to the solenoid as shown in the figure.
- ★ If the actuated solenoid plunger (Needle Valve) does not pop out when the Test Voltage is applied, replace it with a new one.

#### NOTE

- If necessary, push the plunger slightly for the plunger to withdraw.

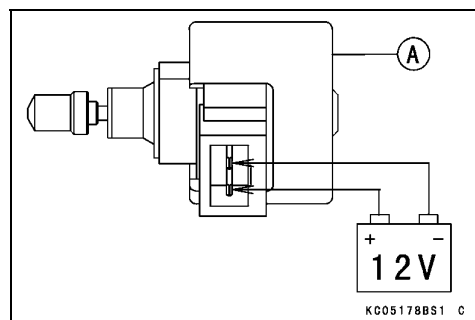

## Intake Manifold

### ***Intake Manifold Removal***

- Remove the carbretor (see Carbretor Removal).
- Unscrew the intake manifold mounting bolts [A].
- Remove the intake manifold [B] and gaskets.
  - FS and FX Models [C]
  - FR Models [D]

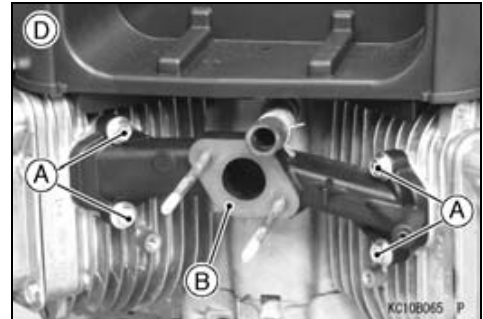
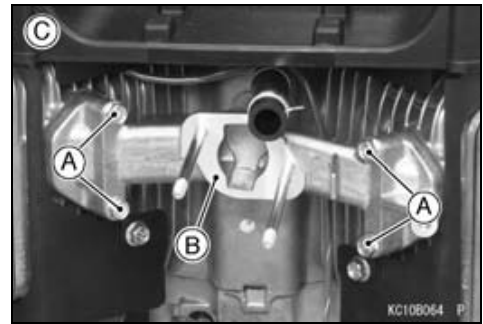

### ***Intake Manifold Installation***

- Replace the intake manifold gaskets [A] with new ones.
- Clean the mating surfaces of the cylinders and intake manifolds.
- Install the intake manifold gaskets.
- Install the intake manifold.
  - FS and FX Models [B]
  - FR Models [C]

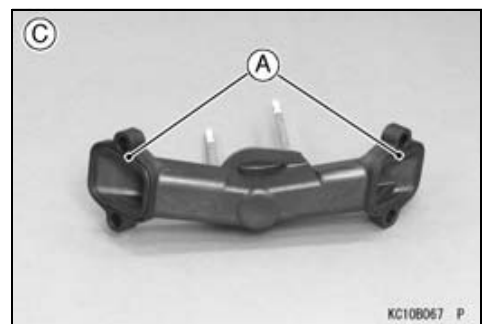
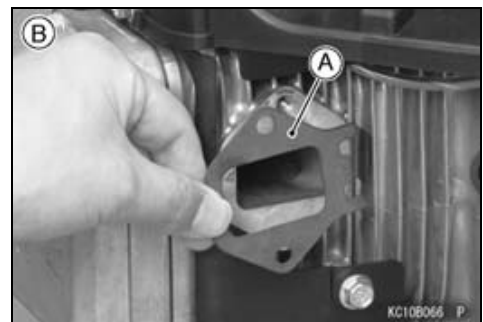

## 3-28 FUEL SYSTEM

### Intake Manifold

- Tighten the intake manifold mounting bolts following the tightening sequence.

**Torque - Intake Manifold Mounting Bolts (FS and FX Models): 5.9 N·m (0.60 kgf·m, 52 in·lb)**

**Intake Manifold Mounting Bolts (FR Models): 8.8 N·m (0.90 kgf·m, 78 in·lb)**

- Install the removed parts (see appropriate chapters).  
FS and FX Models [A]  
FR Models [B]

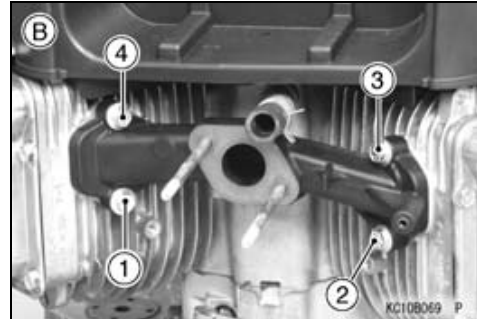
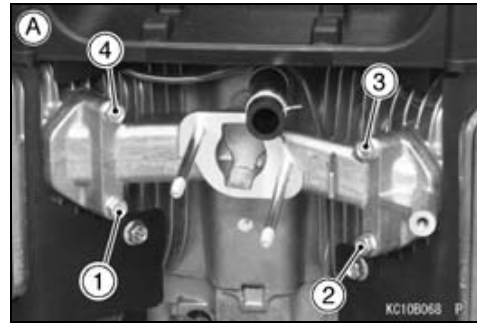

#### ***Intake Manifold Inspection***

- Inspect the intake manifold for cracks or porous casting.
- Cracks not visible to the eye may be detected by using a metal crack detection system (Visual color check: commonly found at automotive parts store.)
- ★ If a crack is present in the intake manifold, replace it.
- Inspect the gasket surfaces for burrs and nicks.

## Fuel Pump, Fuel Filter

The diaphragm in the fuel pump operates by the pulse generated in the crankcase, and the fuel pump supplies fuel to the carburetor.

The fuel pump disassembly is not recommended, if any damage for the pump is noticed replace it with a new one.

### Fuel Pump Removal

- Remove:
  - Fuel Tubes [A]
  - Pulse Tube [B]
  - Screws [C]
  - Fuel Pump [D]

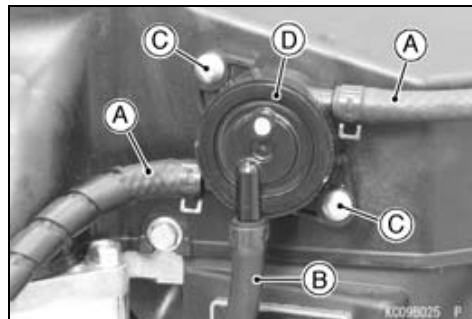

### Fuel Pump Installation

- Connect the fuel tubes [A] and pulse tube [B] fully.
- Tighten the fuel pump mounting screws [C].

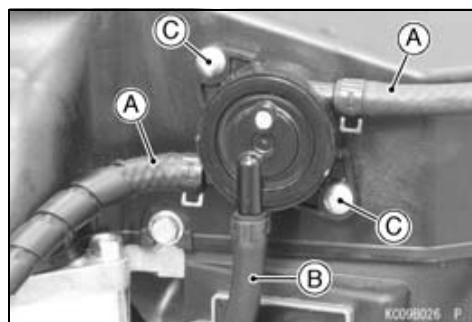

### Fuel Pump Inspection

- Check the vent holes [A] and filter [B] for plugging or clogging.
- ★ If vent hole and filter are plugged or clogged, remove the foreign material from them.

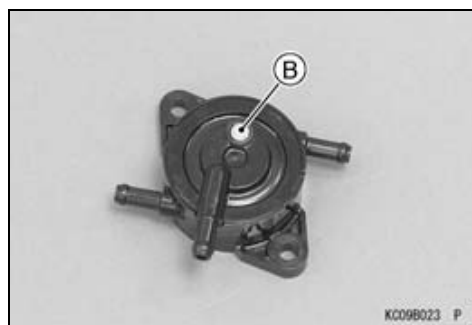
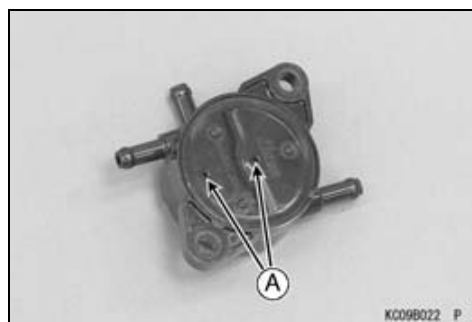

## 3-30 FUEL SYSTEM

### Fuel Pump, Fuel Filter

#### Fuel Flow Test

#### **⚠ WARNING**

Gasoline is extremely flammable and can be explosive under certain conditions. Turn the engine switch off. Do not smoke. Make sure the area is well ventilated and free from any source of flame or sparks; this includes any appliance with a pilot light.

- Disconnect the fuel pump outlet nozzle from the tube.
- Connect a suitable hose [A] to the outlet nozzle.
- Run the lower end of the hose into a container.
- Start the engine, check the fuel flow.
- ★ If fuel flow is none or little, replace the fuel pump with a new one.
- ★ Check for clogged or damaged tubes and fuel filter. Replace the faulty parts.

#### **Fuel Filter Removal/Installation**

- Remove:
  - Clamp [A]
  - Fuel Filter [B]
- When install the fuel filter, arrow mark [C] faces fuel pump side.

#### **Fuel Filter Inspection**

- Visually inspect the fuel filter [A].
- ★ If the filter is clear with no signs of dirt or other contamination, replacement of the fuel filter is not necessary.
- ★ If the filter is dark or looks dirty, replace it with a new one. Also check the rest of the fuel system for contamination.

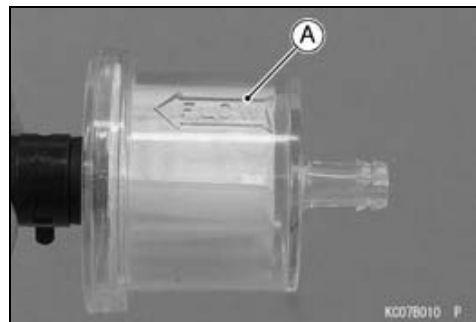
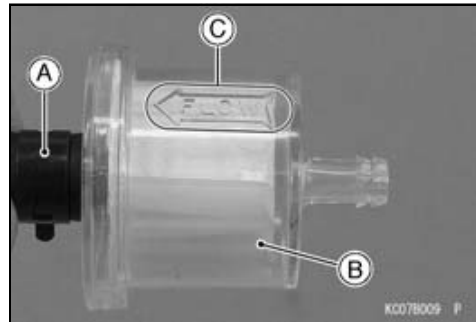

**Air Cleaner**

**Element Removal**

**FX Models**

- Unhook the two retaining clamps [A] and remove the cap [B] from the air cleaner body.

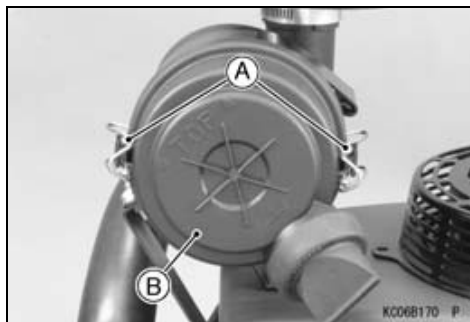

- Remove the primary element [A].



**FS Models**

- Turn the fasteners [A] clockwise.
- Remove the air cleaner cover [B].

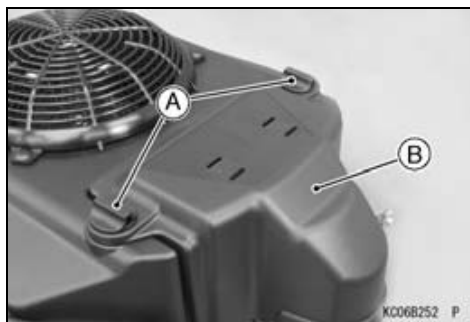

- Loosen the clamp [A].
- Remove the intake hose [B] together with the element assembly [C].

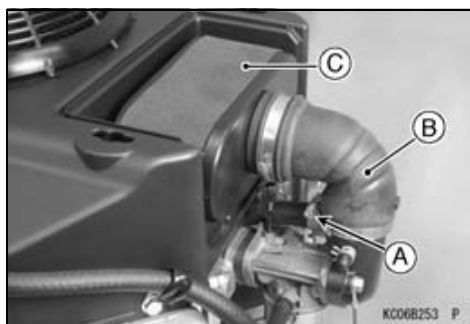

- Loosen the clamp [A].
- Remove:
  - Intake Hose [B]
  - Foam Element [C]

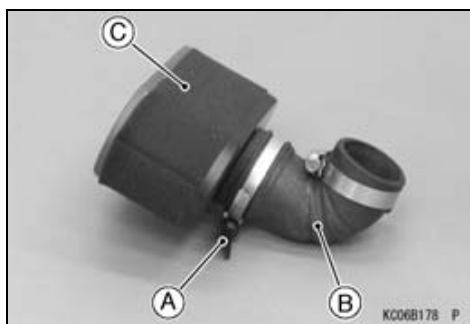

## 3-32 FUEL SYSTEM

### Air Cleaner

#### FR Models

- Open the air cleaner cover [A].
- Loosen the clamp [B].
- Remove the intake hose [C] together with the element assembly [D].

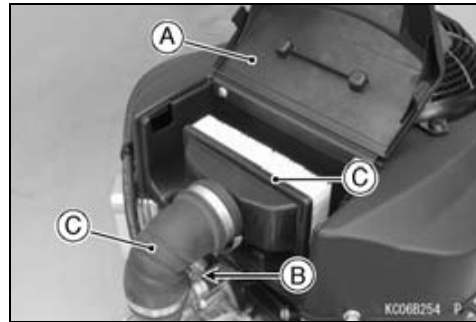

- Loosen the clamp [A].
- Remove the intake hose [B].

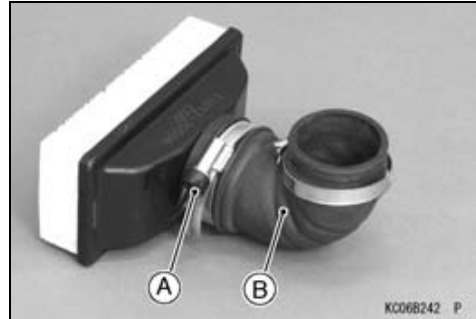

#### Element Installation

##### FX Models

- Slide the primary element into place in the air cleaner body.
- Install the cap direction as shown in the figure.  
Upside [A]  
45° [B]
- Fasten the two retaining clamps [C].

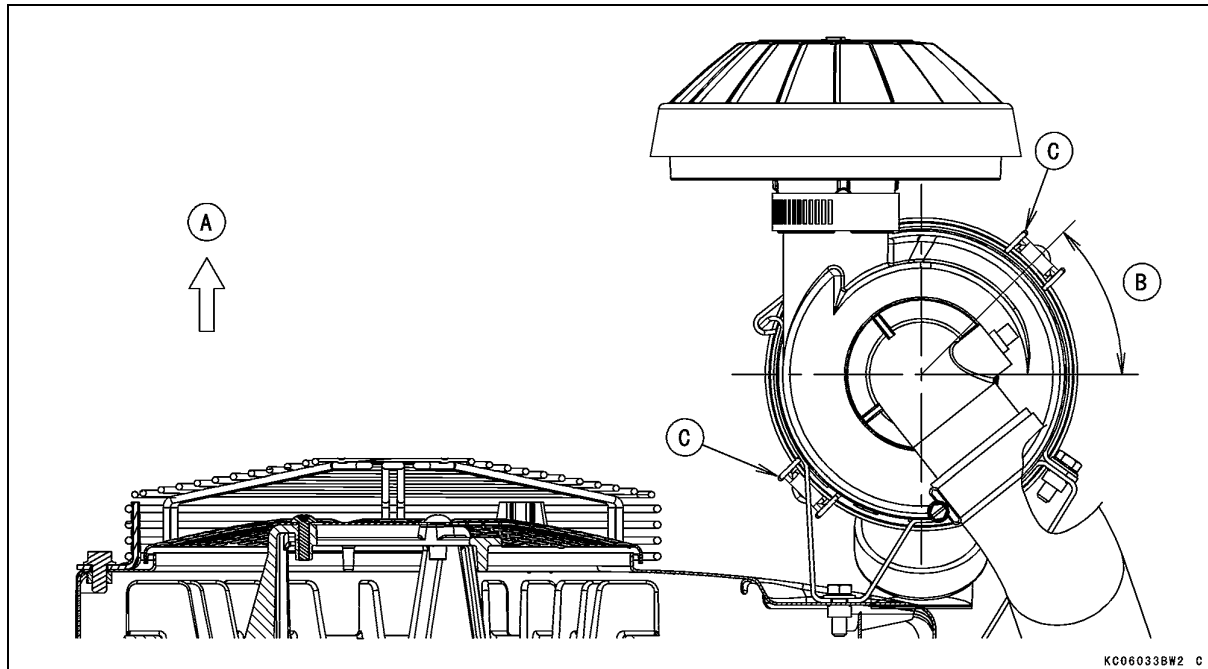

**Air Cleaner**

**FS Models**

- Install the foam element [A] to the paper element [B].

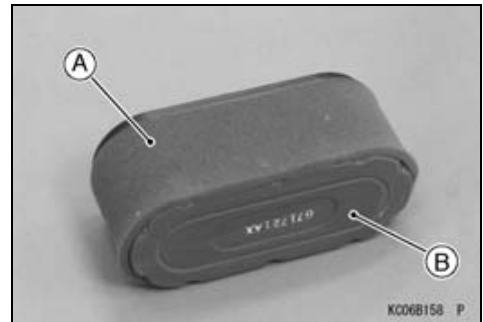

- Install the intake hose [A], and tighten the clamp [B].
- Check that the element [C] is horizontally installed.

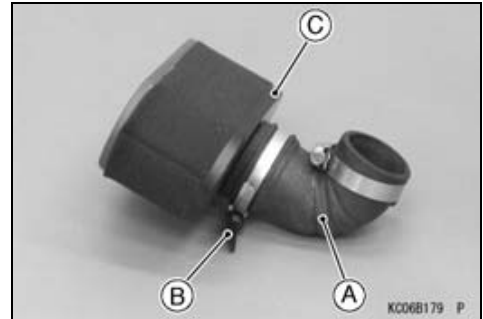

- Install the intake hose [A], and tighten the clamp [B].

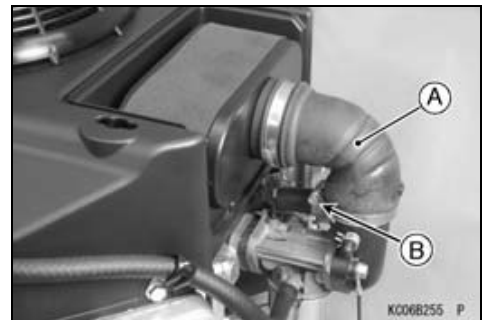

- Install the air cleaner cover [A].
- Turn the fasteners [B] counterclockwise.

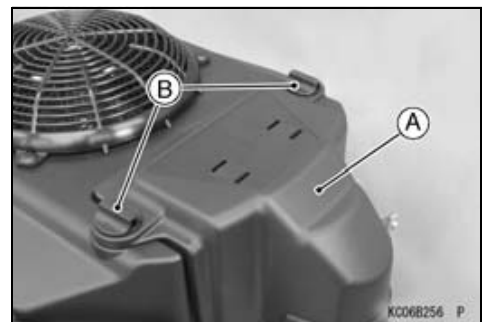

**FR Models**

- Install the intake hose [A], and tighten the clamp [B].
- Check that the element [C] is horizontally installed.

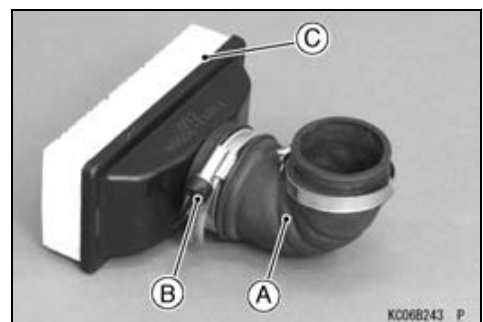

## 3-34 FUEL SYSTEM

### Air Cleaner

- Install the intake hose [A], and tighten the clamp [B].
- Close the air cleaner cover [C].

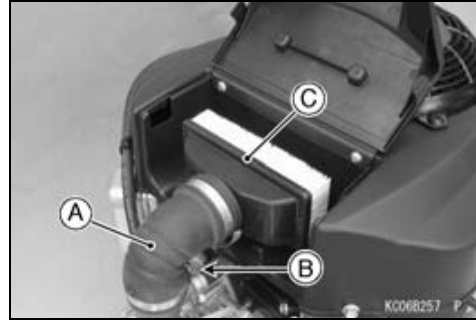

### **Element Cleaning and Inspection**

Air cleaner elements are not recommended to be cleaned, and each air cleaner element should be replaced with new ones.

- Refer to the Element Cleaning and Inspection in the Periodic Maintenance chapter.

### **Air Cleaner Body and Bracket Removal**

#### **FX Models**

- Remove the air cleaner elements, if necessary (see Element Removal).
- Loosen the clamp [A].
- Remove:
  - Bolt [B]
  - Holder Bracket [C]
- Take out the air cleaner body [D] together with the intake hose [E].
- Remove:
  - Bolts [A]
  - Bracket [B]

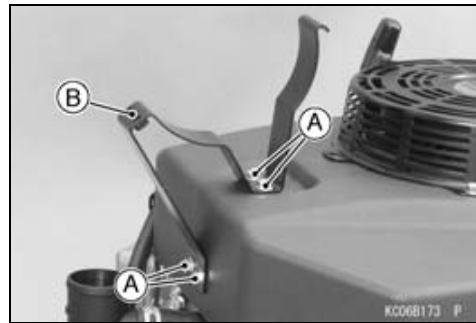
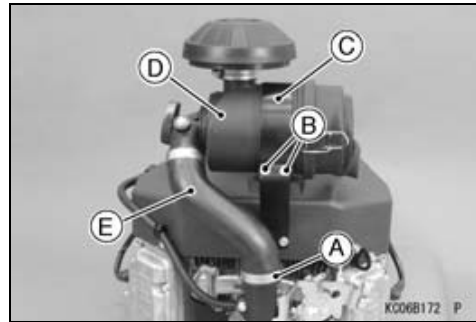

### **Air Cleaner Body and Bracket Installation**

#### **FX Models**

- Install the air cleaner bracket [A].
- Tighten:
  - Torque - Air Cleaner Bracket Mounting Bolts [B]: 5.9 N·m (0.60 kgf·m, 52 in·lb)

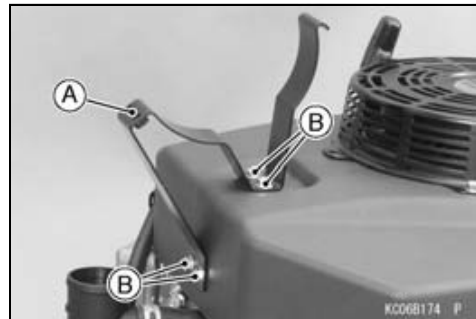

## Air Cleaner

- Set the air cleaner body [A] onto the lower bracket so that the air intake duct [B] is facing upward.
- Install the intake hose [C], and tighten the clamp [D].
- Install the upper bracket [E].
- Tighten:

**Torque - Air Cleaner Holder Bracket Bolts [F]: 5.9 N·m (0.60 kgf·m, 52 in·lb)**

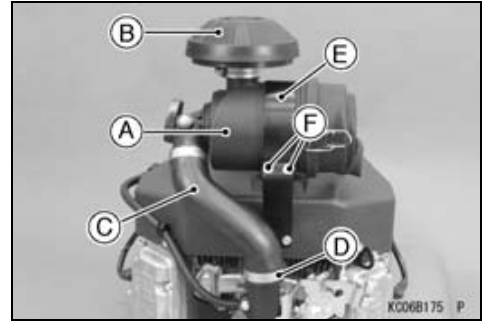

### *Air Cleaner Housing (Cap and Body) Inspection*

#### **FX Models**

- Refer to the Air Cleaner Housing (Cap and Body) Inspection in the Periodic Maintenance chapter.



# Cooling System

## Table of Contents

Exploded View.....	4-2
Cooling Fan .....	4-10
Cooling Fan Removal .....	4-10
Cooling Fan Installation .....	4-10
Cooling Fan Inspection .....	4-10
Engine Shroud.....	4-11
Engine Shroud Removal.....	4-11
Engine Shroud Installation.....	4-13

# 4-2 COOLING SYSTEM

## Exploded View

### Electric Starter Model (FX Models)

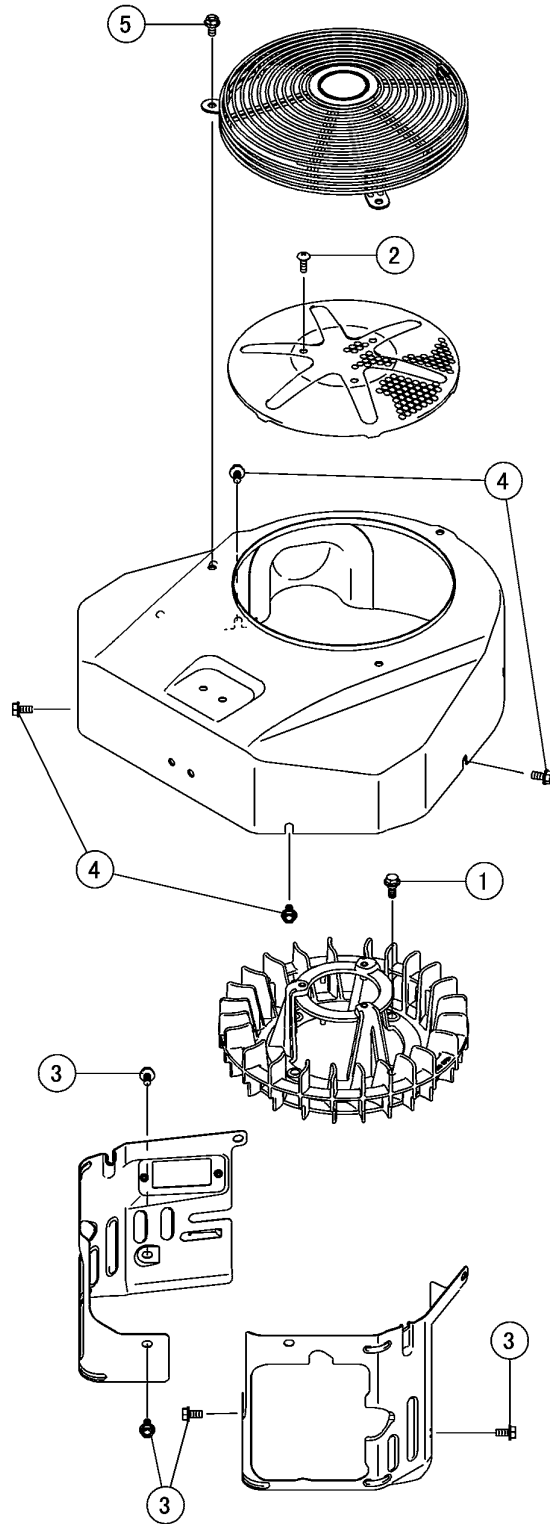

**Exploded View**

<b>No.</b>	<b>Fastener</b>	<b>Torque</b>			<b>Remarks</b>
		<b>N·m</b>	<b>kgf·m</b>	<b>ft·lb</b>	
1	Cooling Fan Mounting Bolts	8.8	0.90	78 in·lb	
2	Cooling Fan Screen Screws	3.0	0.31	27 in·lb	
3	Engine Shroud Bolts	5.9	0.60	52 in·lb	
4	Fan Housing Bolts	5.9	0.60	52 in·lb	
5	Guard Mounting Bolts	5.9	0.60	52 in·lb	

# 4-4 COOLING SYSTEM

## Exploded View

### Electric Starter Model (FS Models)

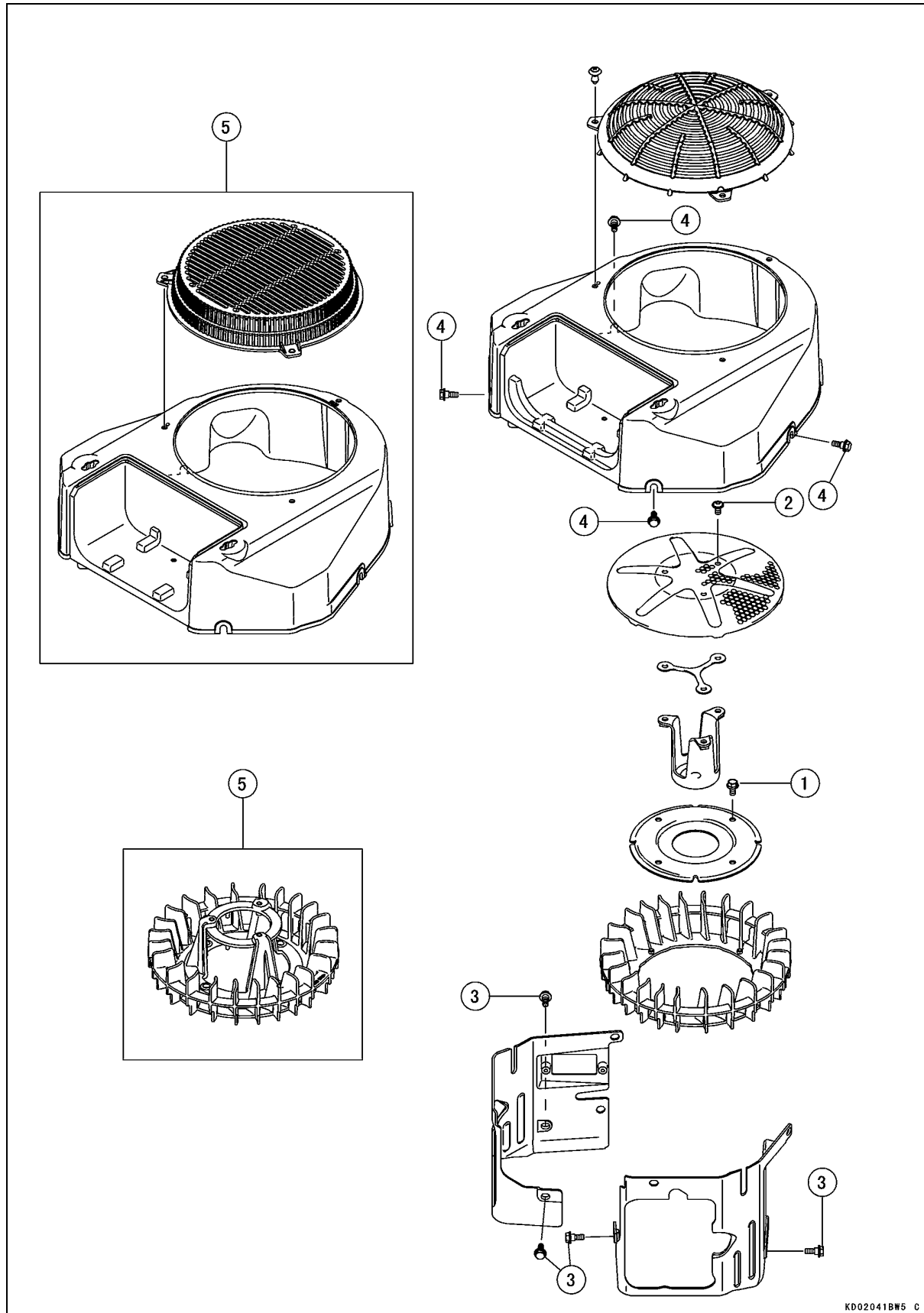

## COOLING SYSTEM 4-5

### Exploded View

No.	Fastener	Torque			Remarks
		N·m	kgf·m	ft·lb	
1	Cooling Fan Mounting Bolts	8.8	0.90	78 in·lb	
2	Cooling Fan Screen Screws	3.0	0.31	27 in·lb	
3	Engine Shroud Bolts	8.8	0.90	78 in·lb	
4	Fan Housing Bolts	8.8	0.90	78 in·lb	

5. FS481/541/600V-AS00 ~ DS00 Models

# 4-6 COOLING SYSTEM

## Exploded View

### Electric Starter Model (FR Models)

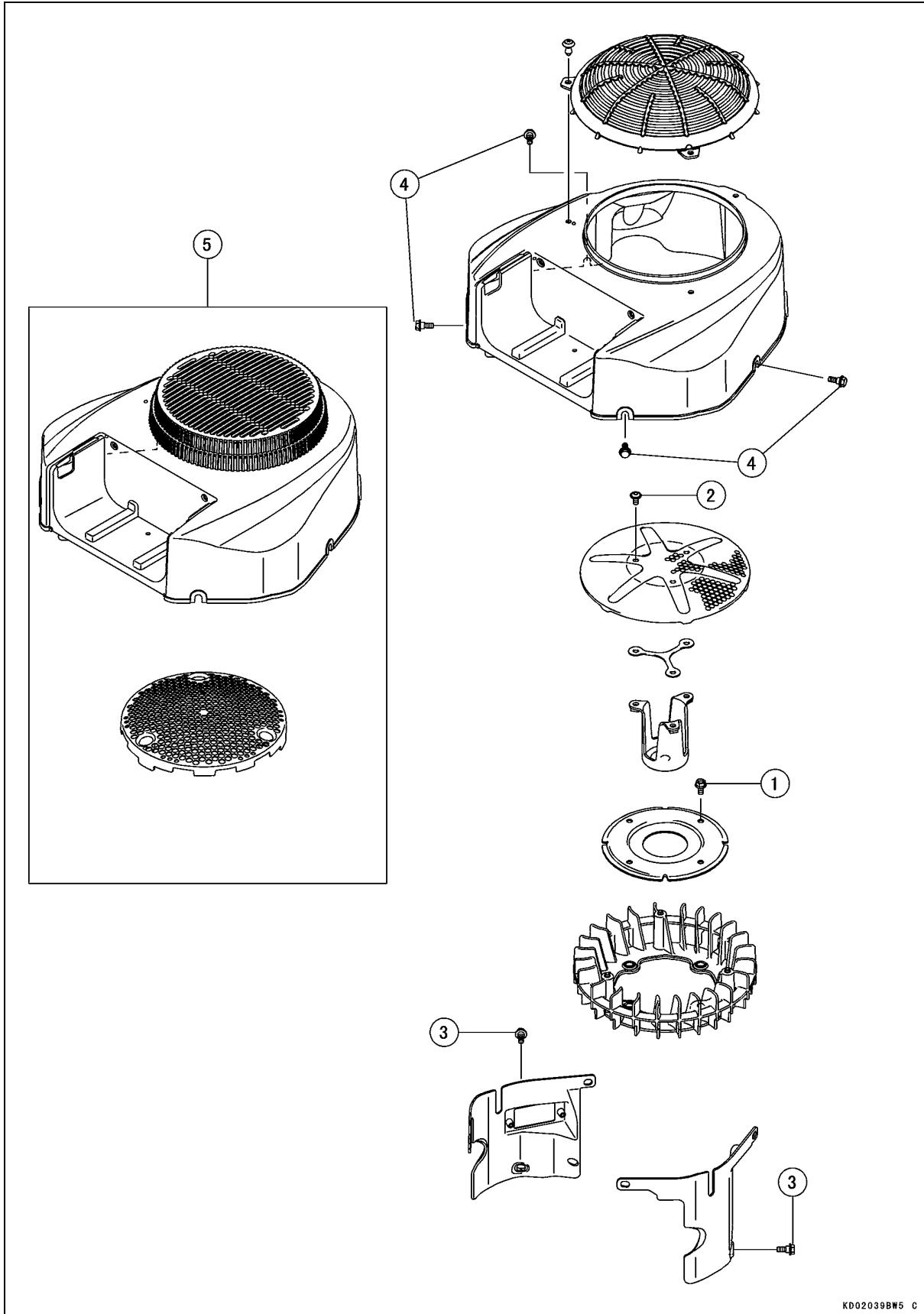

## COOLING SYSTEM 4-7

### Exploded View

No.	Fastener	Torque			Remarks
		N·m	kgf·m	ft·lb	
1	Cooling Fan Mounting Bolts	8.8	0.90	78 in·lb	
2	Cooling Fan Screen Screws	3.0	0.31	27 in·lb	
3	Engine Shroud Bolts	8.8	0.90	78 in·lb	
4	Fan Housing Bolts	8.8	0.90	78 in·lb	

5. FR541/600V-AS00 ~ CS00 Models

# 4-8 COOLING SYSTEM

## Exploded View

### Recoil Starter Model

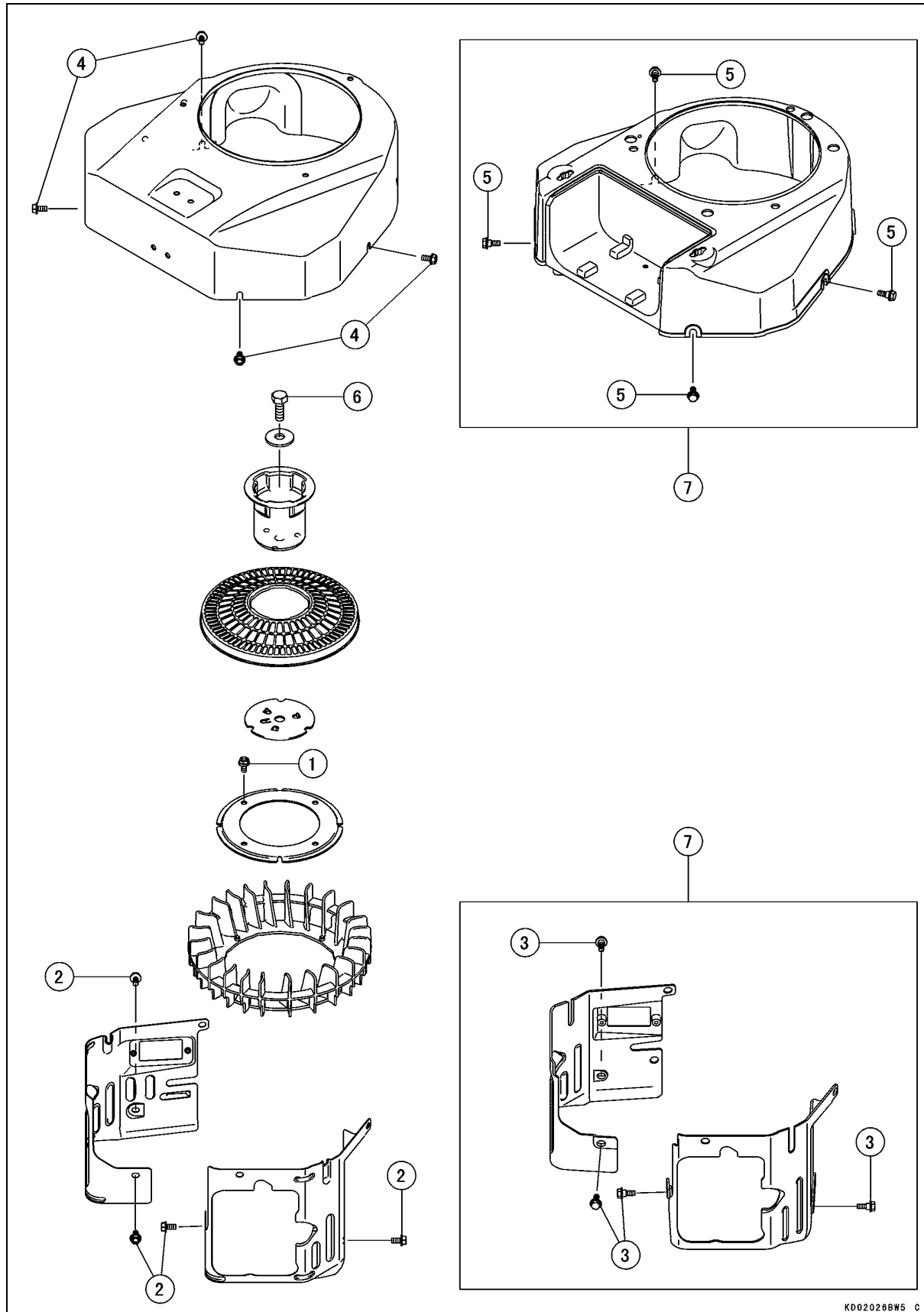

**Exploded View**

No.	Fastener	Torque			Remarks
		N·m	kgf·m	ft·lb	
1	Cooling Fan Plate Mounting Bolts	5.9	0.60	52 in·lb	
2	Engine Shroud Bolts (FX Models)	5.9	0.60	52 in·lb	
3	Engine Shroud Bolts (FS Models)	8.8	0.90	78 in·lb	
4	Fan Housing Bolts (FX Models)	5.9	0.60	52 in·lb	
5	Fan Housing Bolts (FS Models)	8.8	0.90	78 in·lb	
6	Flywheel Bolts	56	5.7	41	

7. FS Models

## 4-10 COOLING SYSTEM

### Cooling Fan

#### **Cooling Fan Removal**

- Refer to the Flywheel and Stator Coil Removal in the Electrical System chapter.

#### **Cooling Fan Installation**

- Refer to the Flywheel and Stator Coil Installation in the Electrical System chapter.

#### **Cooling Fan Inspection**

- Remove the fan housing (see Flywheel and Stator Coil Removal in the Electrical System chapter).
- Visually inspect the blades [A] in the cooling fan.
- ★ If they have any crack, warp or damage, replace the cooling fan with a new one.
- ★ If any mud or dust have stuck to the cooling fan, clean it.
- Wash the cooling fan in detergent and water.

#### **NOTICE**

**Do not clean the cooling fan in oil solvent. It may be damage by oil solvent.**

Electric Starter Model (FX Models) [B]

Electric Starter Model (FS and FR Models) [C]

Recoil Starter Model (FX Models) [D]

Recoil Starter Model (FS Models) [E]

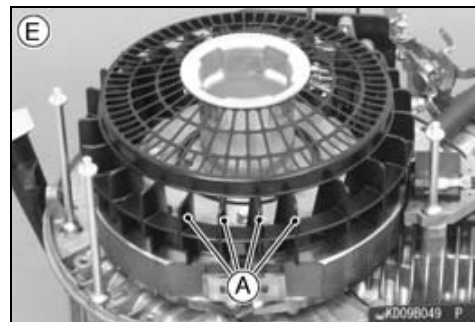
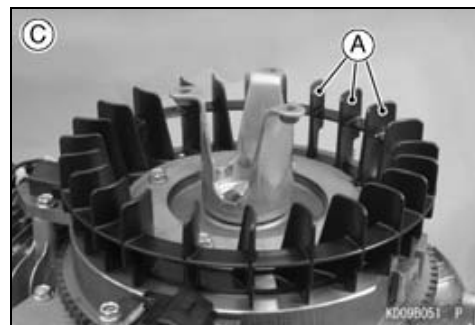
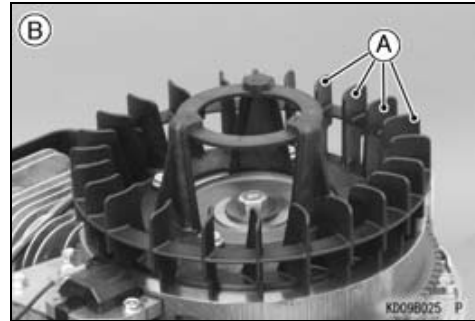

## Engine Shroud

### Engine Shroud Removal

#### Electric Starter Model

- Remove:
  - Fan Housing (see Flywheel and Stator Coil Removal in the Electrical System chapter)
  - Lift Hook (see Cylinder Head Assembly Removal in the Engine Top End chapter) (FS and FX Models)
  - Stator Coil Lead Connector (see Regulator Removal in the Electrical System chapter)
  - Spark Plug Caps [A]
  - Engine Shroud Bolts [B]
  - Engine Shrouds [C]
  - FS and FX Models [D]
  - FR Models [E]

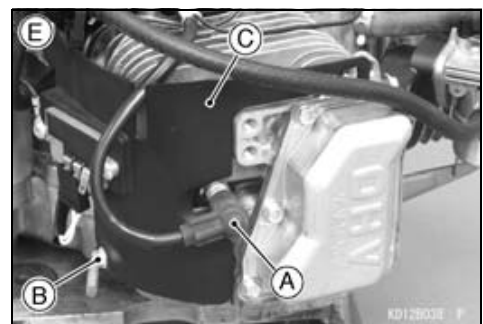
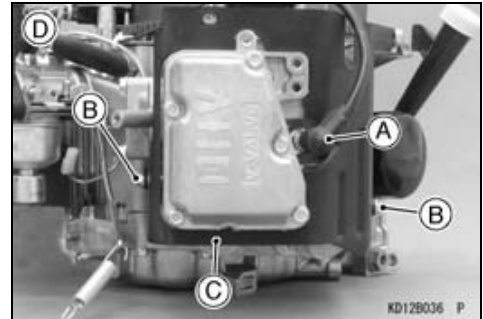
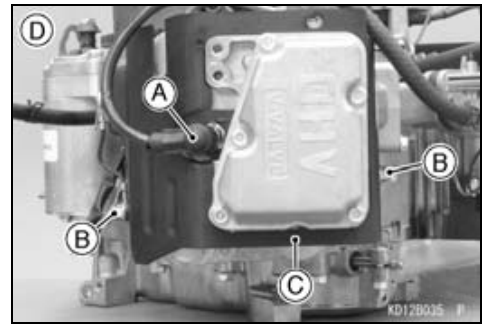

#### FX Models

- Free the stator coil lead [A], stop switch lead [B] and solenoid valve connector lead [C] from the engine shroud clamp [D].

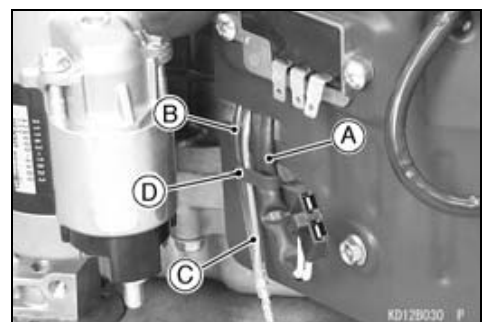

## 4-12 COOLING SYSTEM

### Engine Shroud

#### FS and FR Models

- Cut off the band [A].

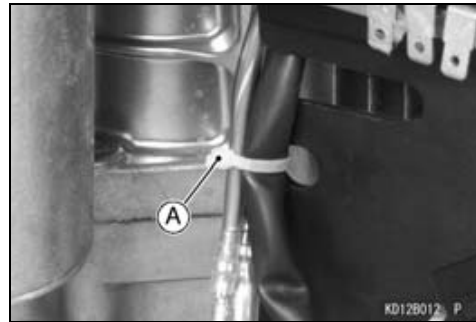

#### Recoil Starter Model

- Remove:
  - Fan Housing (see Flywheel and Stator Coil Removal in the Electrical System chapter)
  - Lift Hook (see Cylinder Head Assembly Removal in the Engine Top End chapter)
  - Spark Plug Caps [A]
  - Engine Shroud Bolts [B]
  - Engine Shrouds [C]

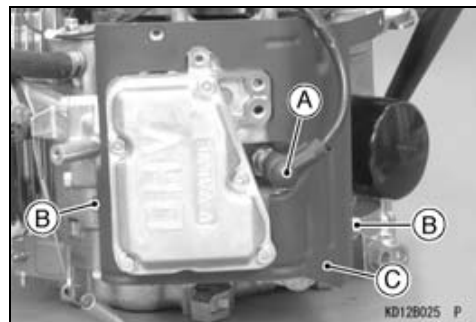
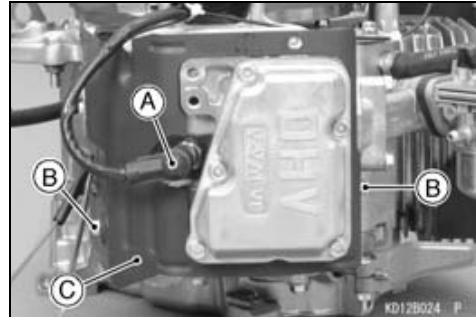

#### FX Models

- Free the stator coil lead [A] and stop switch lead [B] from the engine shroud clamp [C].

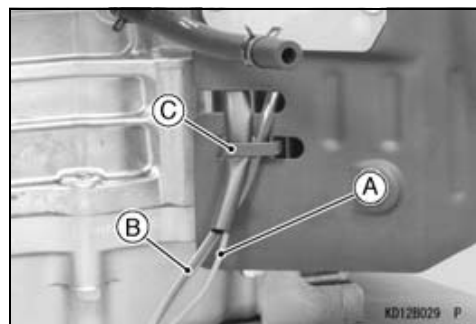

#### FS Models

- Cut off the band [A].

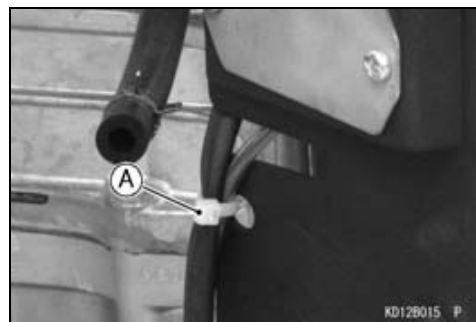

## Engine Shroud

### Engine Shroud Installation

#### Electric Starter Model

- Install the engine shrouds [A].
- Tighten the engine shroud bolts [B].

Torque - Engine Shroud Bolts: 5.9 N·m (0.60 kgf·m, 52 in·lb)  
(FX Models)

Engine Shroud Bolts: 8.8 N·m (0.90 kgf·m, 78 in·lb)  
(FS and FR Models)

- Install the spark plug caps [C].  
FS and FX Models [D]  
FR Models [E]

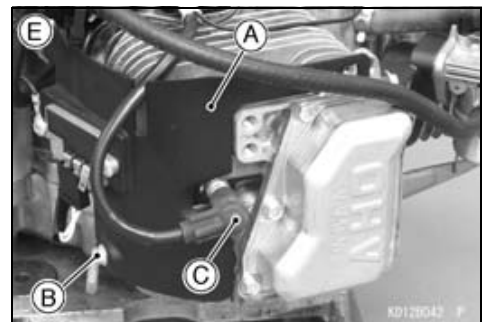
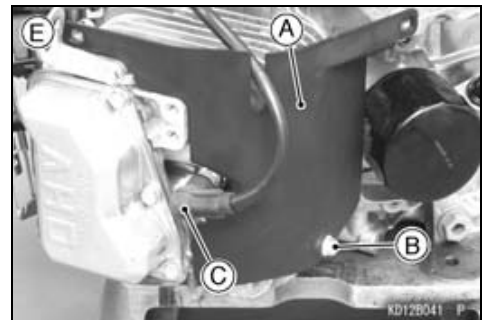
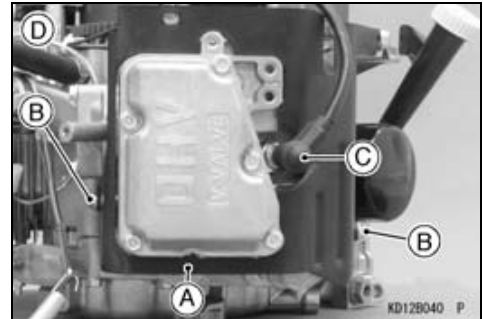
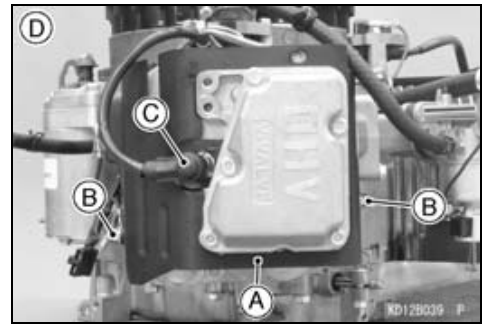

#### FX Models

- Attach the stator coil lead [A], stop switch lead [B] and solenoid valve connector lead [C] to the engine shroud clamp [D] as shown in the figure.

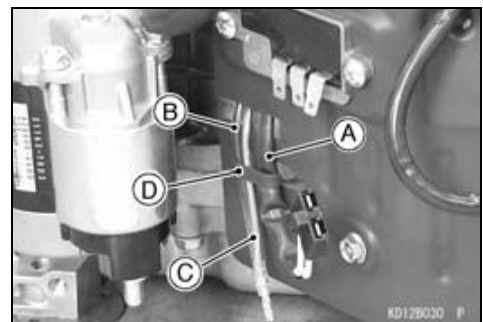

## 4-14 COOLING SYSTEM

### Engine Shroud

#### FS and FR Models

- Attach the stator coil lead [A], stop switch lead and solenoid valve connector lead to the engine shroud with the band [B].

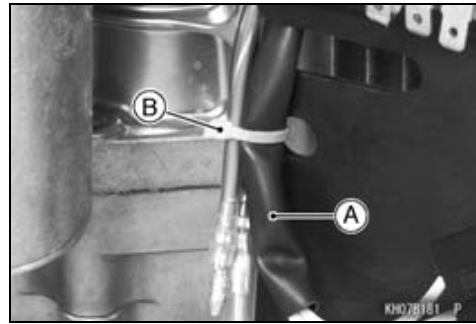

- Install the removed parts (see appropriate chapters).

#### Recoil Starter Model

- Install the engine shrouds [A].
- Tighten the engine shroud bolts [B].

**Torque - Engine Shroud Bolts: 5.9 N·m (0.60 kgf·m, 52 in·lb)  
(FX Models)**

**Engine Shroud Bolts: 8.8 N·m (0.90 kgf·m, 78 in·lb)  
(FS Models)**

- Install the spark plug caps [C].

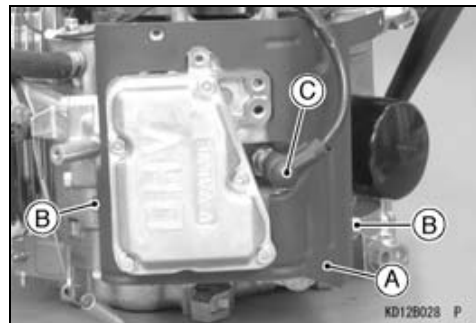
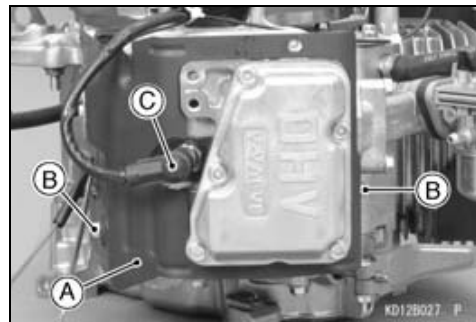

#### FX Models

- Attach the stator coil lead [A] and stop switch lead [B] to the engine shroud clamp [C] as shown in the figure.

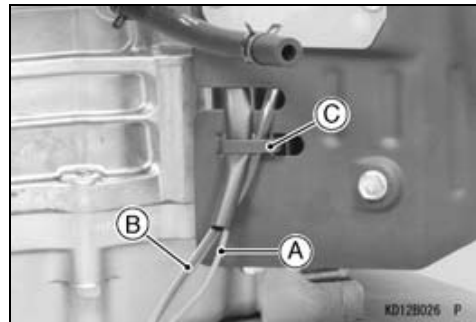

#### FS Models

- Attach the stator coil lead [A] and stop switch lead [B] to the engine shroud with the band [C].

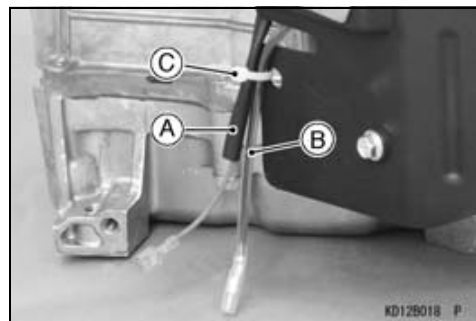

- Install the removed parts (see appropriate chapters).

# Engine Top End

## Table of Contents

Exploded View.....	5-2
Specifications .....	5-4
Special Tools .....	5-6
Cylinder Head.....	5-7
Compression Measurement.....	5-7
Cylinder Head Assembly Removal .....	5-8
Cylinder Head Assembly Installation .....	5-9
Push Rod Removal.....	5-10
Push Rod Installation.....	5-11
Push Rod Inspection.....	5-11
Valve Mechanism Removal/Installation .....	5-11
Cylinder Head Cleaning.....	5-13
Cylinder Head Inspection.....	5-14
Rocker Arm Inspection.....	5-14
Valves .....	5-15
Valve Clearance Inspection .....	5-15
Valve Clearance Adjustment.....	5-15
Valve Seat Inspection .....	5-15
Valve Seat Repair .....	5-15
Valve Head Thickness .....	5-15
Valve Stem Runout .....	5-15
Valve Stem Diameter .....	5-15
Valve Guide Inside Diameter .....	5-16
Valve Spring Inspection .....	5-16
Cylinder, Piston.....	5-17
Piston Removal.....	5-17
Piston Installation.....	5-18
Piston/Cylinder Seizure.....	5-20
Piston Cleaning.....	5-20
Piston Ring and Ring Groove Wear.....	5-21
Piston Ring End Gap .....	5-22
Piston Pin, Piston Pin Hole, and Connecting Rod Wear.....	5-22
Piston Diameter .....	5-23
Cylinder Inside Diameter.....	5-23
Cylinder Boring and Honing.....	5-23



**Exploded View**

No.	Fastener	Torque			Remarks
		N·m	kgf·m	ft·lb	
1	Connecting Rod Big End Cap Bolts	9.8	1.0	87 in·lb	EO
2	Cylinder Head Bolts (L = 50 mm)	27.4	2.8	20	S
3	Cylinder Head Bolts (L = 70 mm)	27.4	2.8	20	S
4	Lift Hook Bolt	5.9	0.60	52 in·lb	
5	Rocker Arm Bracket Bolts	14.7	1.5	11	L
6	Rocker Cover Bolts	5.9	0.60	52 in·lb	S
7	Spark Plugs	22	2.2	16	
8	Valve Clearance Adjusting Locknuts	11	1.1	97 in·lb	

9. FR Models

EO: Apply engine oil.

L: Apply a non-permanent locking agent.

ME: Apply molybdenum disulfide oil.

(mixture of the engine oil and molybdenum disulfide grease in a volume ratio 1:1)

MO: Apply molybdenum disulfide oil.

(mixture of the engine oil and molybdenum disulfide grease in a weight ratio 10:1)

R: Replacement Parts

S: Tighten the fasteners following the specified sequence.

## 5-4 ENGINE TOP END

### Specifications

Item	Service Limit
<b>Cylinder Head</b> Cylinder Compression (MIN)  Cylinder Head Warp	448 kPa (64 psi) @ Engine Oil Temperature 50 ~ 60°C (122 ~ 144°F), Cranking Speed 500 rpm/5 Seconds  0.05 mm (0.002 in.)
<b>Valves</b> Valve Head Thickness: Intake, Exhaust Valve Stem Runout: Intake, Exhaust Valve Stem Diameter: Intake Exhaust Valve Guide Inside Diameter: Intake, Exhaust Valve Spring Free Length: Intake, Exhaust Rocker Arm Push Rod Runout: Intake, Exhaust Rocker Arm Collar Outside Diameter: Intake, Exhaust Rocker Arm Inside Diameter: Intake, Exhaust	0.35 mm (0.0138 in.)  TIR 0.05 mm (0.002 in.)  5.95 mm (0.234 in.) 5.93 mm (0.233 in.)  6.08 mm (0.239 in.)  31.0 mm (1.22 in.)  TIR 0.5 mm (0.02 in.)  10.91 mm (0.430 in.)  11.13 mm (0.438 in.)
<b>Cylinder, Piston</b> Piston Diameter Piston Ring/Groove Clearance: Top Second Piston Ring Thickness: Top Second Piston Ring End Gap: Top Second Oil Piston Pin Outside Diameter Piston Pin Hole Inside Diameter Connecting Rod Small End Inside Diameter Cylinder Inside Diameter: Standard Cylinder 0.50 mm Oversize Cylinder Cylinder Inside Diameter Out Round:	72.79 mm (2.866 in.)  0.12 mm (0.0047 in.) 0.12 mm (0.0047 in.)  1.1 mm (0.043 in.) 1.1 mm (0.043 in.)  0.7 mm (0.028 in.) 0.9 mm (0.035 in.) 1.05 mm (0.041 in.)  15.96 mm (0.628 in.) 16.08 mm (0.633 in.) 16.05 mm (0.632 in.)  73.10 mm (2.878 in.) 73.60 mm (2.898 in.)  0.05 mm (0.002 in.)

## Specifications

Item	Standard
Valve Clearance: Intake, Exhaust	0.10 ~ 0.15 mm (0.0039 ~ 0.059 in.)
Valve Seating Surface Angle: Intake, Exhaust	45°
Valve Seating Surface Width: Intake Exhaust	0.8 ~ 1.4 mm (0.031 ~ 0.055 in.) 0.8 ~ 1.4 mm (0.031 ~ 0.055 in.)
Valves Guide Inside Diameter: Intake, Exhaust	6.000 ~ 6.012 mm (0.2362 ~ 0.2367 in.)
Cylinder Inside Diameter: Standard Cylinder 0.50 mm Oversize Cylinder	72.98 ~ 73.00 mm (2.873 ~ 2.874 in.) 73.48 ~ 73.50 mm (2.893 ~ 2894 in.)

# 5-6 ENGINE TOP END

## Special Tools

**Piston Ring Pliers:**  
**57001-115**

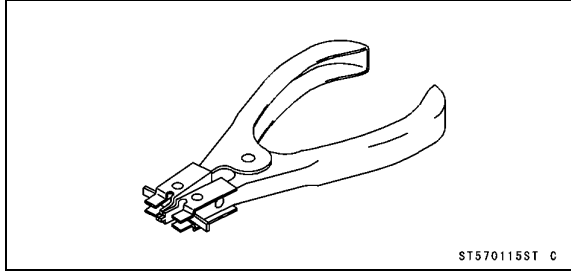

**Piston Ring Compressor Belt,  $\phi 67 \sim \phi 79$ :**  
**57001-1097**

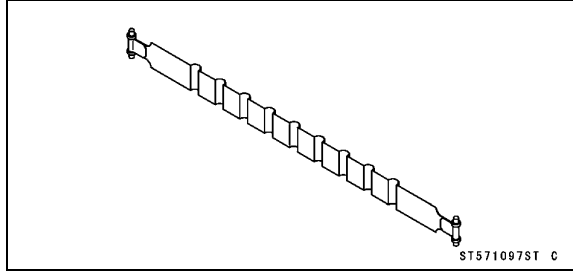

**Compression Gauge, 20 kgf/cm<sup>2</sup>:**  
**57001-221**

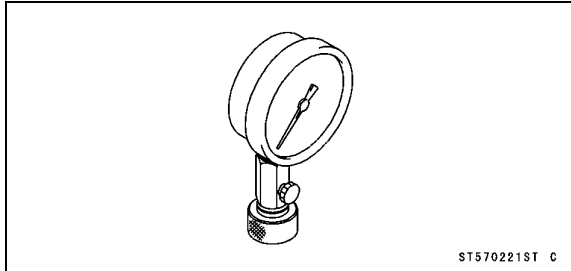

**Compression Gauge Adapter, M14 × 1.25:**  
**57001-1159**

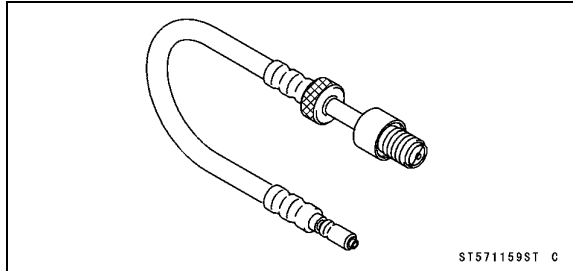

**Piston Ring Compressor Grip:**  
**57001-1095**

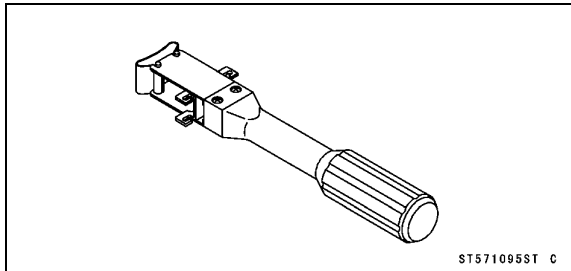

## Cylinder Head

### Compression Measurement

- Before measuring compression, do the following.
  - Be sure the battery is fully charged.
  - Thoroughly warm up the engine so that engine oil between the piston and cylinder wall will help sealing the compression as it does during normal running.
  - Stop the engine.
- Disconnect the spark plug caps of each cylinder and remove the spark plugs.
- Attach the compression gauge assembly firmly into one plug hole.

**Special Tools - Compression Gauge,**  
 20 kgf/cm<sup>2</sup> [A]: 57001-221  
**Compression Gauge Adapter,**  
 M14 × 1.25 [B]: 57001-1159

- Ground the spark plugs to the engine.

### **⚠ WARNING**

**To avoid fire, do not ground the spark plugs in proximity to the plug holes. Keep the plugs as far away as possible from the plug holes.**

- Open the throttle fully. Run the engine by turning the engine switch key several times until the compression gauge stops rising. Read the highest compression value.

**Cylinder Compression (MIN) 448 kPa (64 psi) @ Engine Oil Temperature 50 ~ 60°C (122 ~ 140°F), Cranking Speed 500 rpm/5 Seconds**

- Repeat the measurement on the other cylinder.
- ★ If the compression is higher than the specified value, the piston rings, cylinder and valves are probably in good condition.
- ★ If the compression is too high, check the following.
  1. Carbon build-up on the piston crown and cylinder head - clean off any carbon on the piston crown and cylinder head.
  2. Cylinder head gasket - use only the proper gasket. The use of a gasket of incorrect thickness will change the compression.
  3. Valve guides and piston rings - rapid carbon accumulation in the combustion chamber may be caused by worn valve guides and/or worn piston oil rings. This may be indicated by white exhaust smoke.
- ★ If the cylinder compression is lower than the (MIN), check the following.
  1. Gas leakage around the cylinder head - replace the damaged gasket with a new one and check the cylinder head warp.
  2. Condition of the valve seating.
  3. Valve clearance.
  4. Piston/cylinder wear, piston seizure.
  5. Piston ring, piston ring groove.

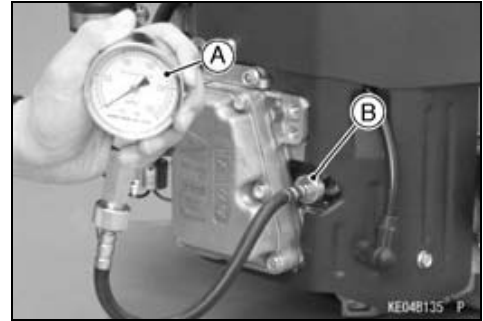

## 5-8 ENGINE TOP END

### Cylinder Head

#### Cylinder Head Assembly Removal

- Remove:
  - Fan Housing (see Flywheel and Stator Coil Removal in the Electrical System chapter)
  - Bolt [A]
  - Lift Hook [B]
  
- Remove:
  - Intake Manifold (see Intake Manifold Removal in the Fuel System chapter)
  - Engine Shroud (see Engine Shroud Removal in the Cooling System chapter)
  - Spark Plugs (see Spark Plug Removal in the Electrical System chapter)
- Unscrew the rocker cover bolts in the order shown [1 to 5].
- Remove the cover [A] and the gasket.
  - FS and FX Models [B]
  - FR Models [C]
  
- When removing the #1, #2 cylinder head, set each piston at the top dead center (T.D.C) [A] of the compression stroke.

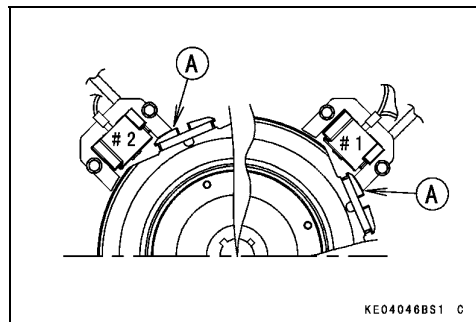
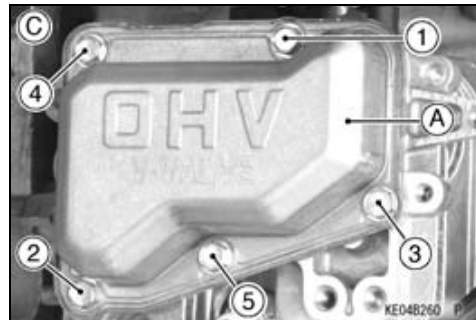
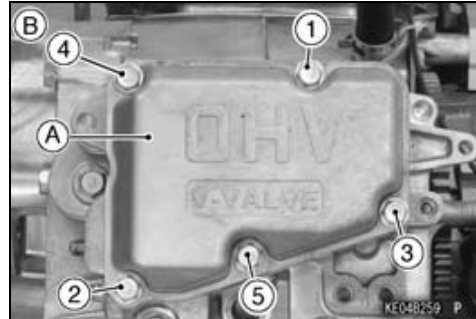
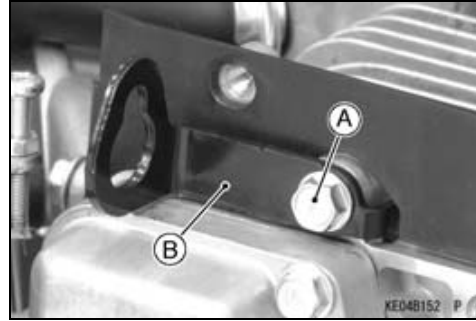

## Cylinder Head

- Remove:
  - Rocker Arm (see Valve Mechanism Removal/Installation)
  - Push Rod (see Push Rod Removal)
  - Rocker Arm Bracket (see Valve Mechanism Removal/Installation)
- Loosen the cylinder head bolts 1/4 turn in the sequence as shown in the figure.

**NOTICE**

**If the above procedure is not followed, the cylinder head may be warped during removal.**

- Repeat the sequence until all bolts are removed and lift off the cylinder head assembly.

**NOTE**

○Mark the push rods and rocker arms so they can be installed in their original position during assembly.

### Cylinder Head Assembly Installation

- Clean the mating surfaces of the cylinder heads and cylinders.
- Replace the gaskets with new ones.
- Install the dowel pins [A].

- Set each piston at the T.D.C [A] of the compression stroke.
- Put new gaskets and the cylinder head assemblies on each cylinder.

**NOTE**

○As the head gaskets are coated with sealing agents, be careful not to damage the surfaces.

- Tighten the cylinder head bolts following the tightening sequence as shown in the figure.

**Torque - Cylinder Head Bolts: 27.4 N·m (2.8 kgf·m, 20 ft·lb)**

**NOTICE**

**A torque wrench must be used to assure proper torque. Improper tightening of the head bolts may result in warping of the cylinder head.**

- Install:
  - Rocker Arm Bracket (see Valve Mechanism Removal/Installation)
  - Push Rod (see Push Rod Installation)
  - Rocker Arm (see Valve Mechanism Removal/Installation)

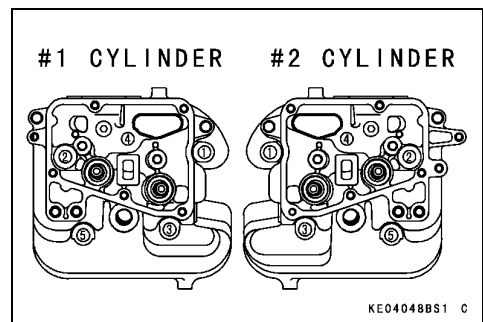
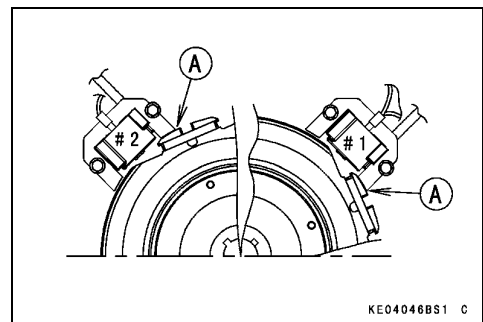
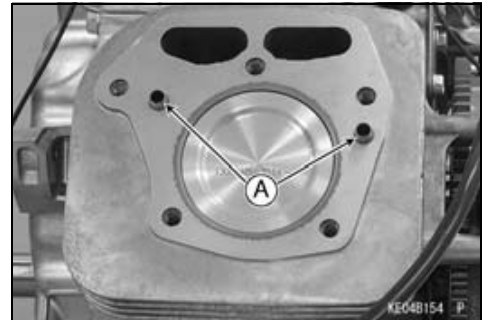
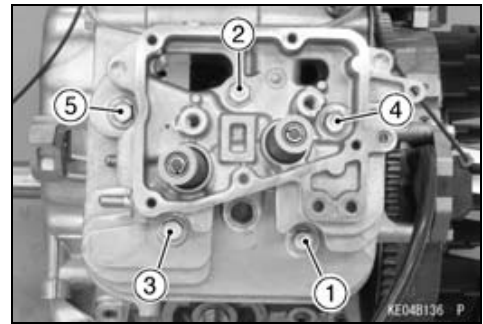

## 5-10 ENGINE TOP END

### Cylinder Head

- Install the new gaskets and rocker covers.
- Tighten the rocker cover bolts following the tightening sequence as shown in the figure.

**Torque - Rocker Cover Bolts: 5.9 N·m (0.60 kgf·m, 52 in·lb)**

FS and FX Models [A]

FR Models [B]

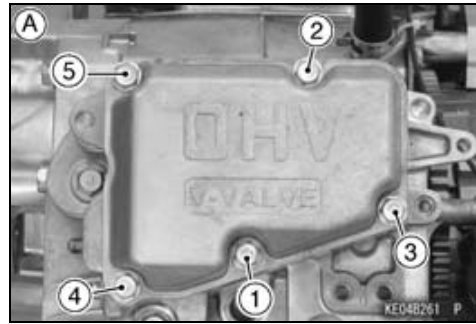

- Install:
  - Spark Plugs (see Spark Plug Installation in the Electrical System chapter)
  - Engine Shroud (see Engine Shroud Installation in the Cooling System chapter)
  - Lift Hook [A]
- Tighten:
  - Torque - Lift Hook Bolt [B]: 5.9 N·m (0.60 kgf·m, 52 in·lb)**
- Install the removed parts (see appropriate chapter).

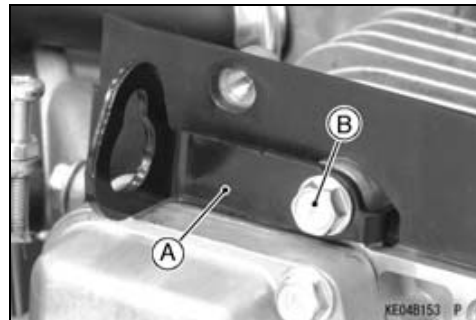

### **Push Rod Removal**

- Set each piston at the T.D.C of the compression stroke.
- Remove the rocker arm (see Valve Mechanism Removal/Installation).
- Remove the push rods [A].

#### **NOTE**

○Mark the push rods and rocker arms so they can be installed in their original position during assembly.

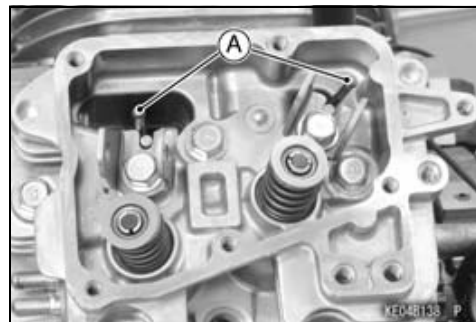

## Cylinder Head

### Push Rod Installation

- Set each piston at the T.D.C of the compression stroke.
- Apply engine oil to the both ends and shaft of the push rod.
- Install the push rods in their original positions of the tappet hollow [A].
- Check that both intake and exhaust push rods on each cylinder are at lowest position on the cam lobes. If the piston is not at the T.D.C of the compression stroke, turn the flywheel clockwise one turn (360°) and reset each piston at the T.D.C of the compression stroke.
- Be sure the end of the push rods are correctly seated on the tappets.
- Install the rocker arm (see Valve Mechanism Removal/Installation).
- Check and adjust the valve clearance (see Valve Clearance Inspection in the Periodic Maintenance chapter).

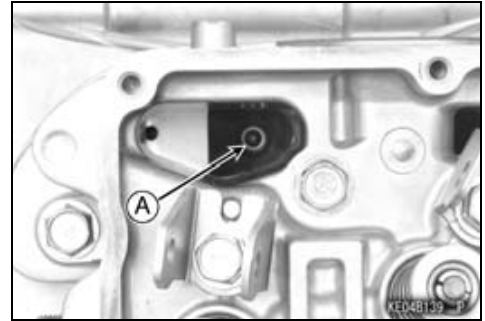

### Push Rod Inspection

- Place the push rod on V blocks as far apart as possible, and set a dial gauge [A] on the rod at a halfway point between the blocks. Turn the rod to measure the runout. The difference between the highest and the lowest dial readings is the amount of runout.
- ★ If the runout exceeds the service limit, replace the rod with a new one.

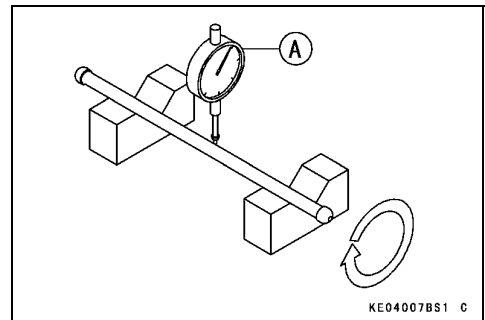

**Rocker Arm Push Rod Runout**  
**Service Limit: TIR 0.5 mm (0.02 in.)**

### Valve Mechanism Removal/Installation

#### NOTE

- When removing the valve mechanism parts, note their position so that they may be reinstalled in their original position during assembly.

- Remove:
  - Valve Clearance Adjusting Locknuts [A]
  - Valve Clearance Adjusting Bolts [B] and Washer Collar
  - Rocker Arm [C]

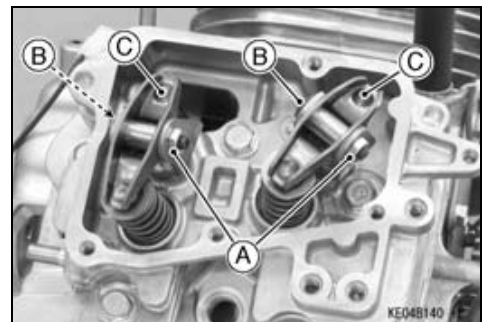

## 5-12 ENGINE TOP END

### Cylinder Head

- Remove:
  - Push Rod (see Push Rod Removal)
  - Rocker Arm Bracket Bolts [A]
  - Rocker Arm Brackets [B]

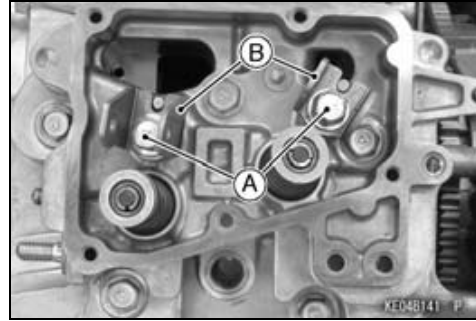

- Remove the cylinder head assembly (see Cylinder Head Assembly Removal).
- Support the valve head in the combustion chamber with a suitable block.
- To remove the collets [A], push down the valve retainer [B] with suitable tool and remove the collets.
- Remove the valve retainer, spring [C] and valve [D] .

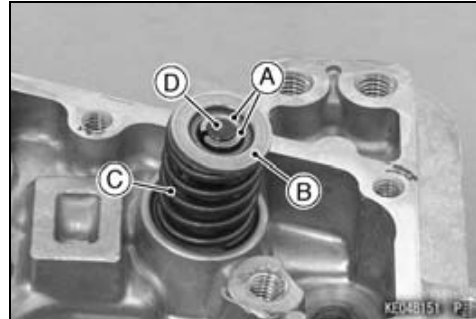

- Remove the stem seals [A].

#### NOTE

- *It is not necessary to remove the stem seal unless it is being replaced.*
- *Valve guide [B] is not replaceable, do no remove it.*

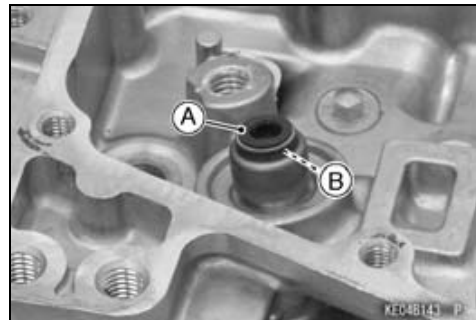

- Apply engine oil to the valve stem to avoid damaging the stem seal.
- Check to see that the valve moves smoothly up and down in the guide.
- Check to see that the valve seats properly in the valve seat [A]. If it does not, repair the valve seat (see Valve Seat Repair in the Periodic Maintenance chapter).
- Valve installation is the reverse of removal.
- Install the cylinder head assembly (see Cylinder Head Assembly Installation).
- Set the each piston at T.D.C of the compression stroke (see Cylinder Head Assembly Installation).

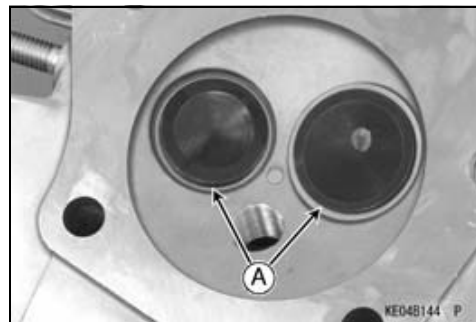

## Cylinder Head

- Install the rocker arm brackets [A] so that bracket hollows [B] fit to the cylinder head projections [C].
- Apply a non-permanent locking agent to the rocker arm bracket bolts, and tighten them.

**Torque - Rocker Arm Bracket Bolts: 14.7 N·m (1.5 kgf·m, 11 ft·lb)**

- Install the push rods (see Push Rod Installation).
- Position the rocker arm [A] so that the hollow side [B] faces push rod.

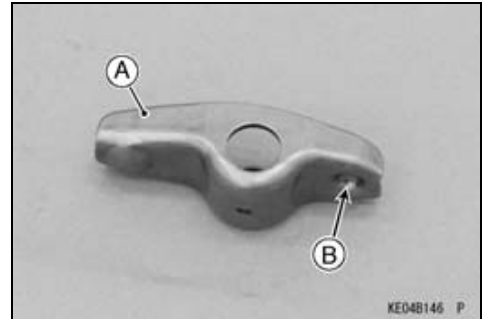
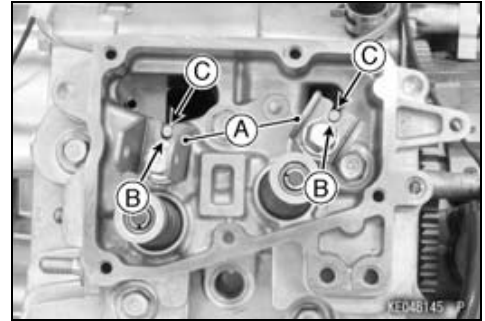

- Apply engine oil to the collars [A].
- For #1 cylinder, insert the collars in to the rocker arm hole so that the flatten side [B] faces PTO side.
- Insert the washers [C] onto the valve clearance adjusting bolts [D], and install them from the flywheel side hole of the rocker arms.
- Align the flatten surface of the collars with the flatten surface [E] of the valve clearance adjusting bolts.
- For #2 cylinder, insert the collars in to the rocker arm hole so that the flatten side faces flywheel side.
- Insert the washers onto the valve clearance adjusting bolts, and install them from the PTO side hole of the rocker arms.
- Align the flatten surface of the collars with the flatten surface of the valve clearance adjusting bolts.
- Tighten the valve clearance adjusting locknuts temporarily.
- Position the push rod end on to the rocker arm hollow.
- Adjust the valve clearance (see Valve Clearance Adjustment in the Periodic Maintenance chapter).

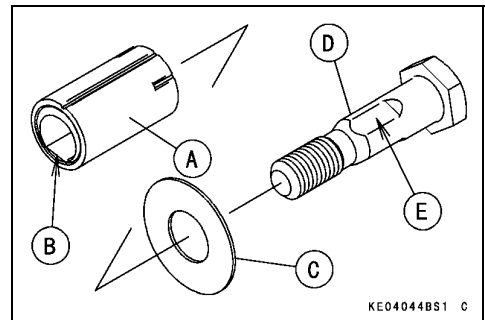

### Cylinder Head Cleaning

- Refer to the Cylinder Head Cleaning in the Periodic Maintenance chapter.

## 5-14 ENGINE TOP END

### Cylinder Head

#### **Cylinder Head Inspection**

- Lay a straightedge [A] across the mating surface of the head at several different points, and measure warp by inserting a thickness gauge [B] between the straightedge and head.
- ★ If warp exceeds the service limit, repair the head by lapping the mating surface with emery paper secured to a surface plate (first No. 200, than No. 400). If the mating surface is badly damaged, replace the cylinder head.

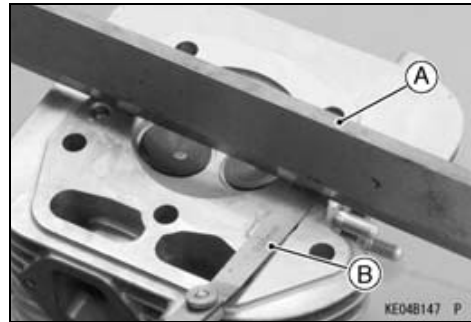

#### **Cylinder Head Warp**

**Service Limit: 0.05 mm (0.002 in.)**

- Check the cylinder head for cracks or other damage.
- Cracks not visible to the eye may be detected by coating the suspected area with mixture of 25% kerosene and 75% light engine oil.
- Wipe the area dry and immediately apply a coating of zinc oxide dissolved in wood alcohol. If a crack is present, the coating will become discolored at the defective area.
- If a crack is present in the cylinder head, replace it.
- Inspect the mating surface for burrs and nicks.

#### **Rocker Arm Inspection**

- Measure the diameter [A] of the rocker arm collar with a micrometer at several points.
- ★ If the outside diameter is less than the service limit, replace the rocker arm collar.

#### **Rocker Arm Collar Outside Diameter**

**Service Limit:**

**Intake, Exhaust                      10.91 mm (0.430 in.)**

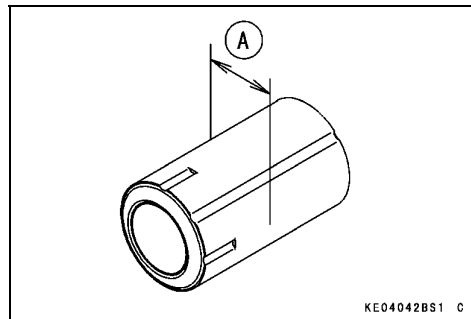

- Clean and inspect the rocker arm where it touches the push rod and valve stem.
- ★ If the contact points [A] are worn or damaged, replace the rocker arm.
- Measure the inside diameter [B] of the rocker arm at several points using a dial bore gauge or inside micrometer.
- ★ If the inside diameter is more than the service limit, replace the rocker arm.

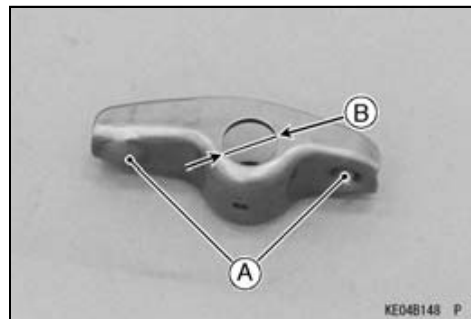

#### **Rocker Arm Inside Diameter**

**Service Limit:**

**Intake, Exhaust                      11.13 mm (0.438 in.)**

## Valves

### Valve Clearance Inspection

- Refer to the Valve Clearance Inspection in the Periodic Maintenance chapter.

### Valve Clearance Adjustment

- Refer to the Valve Clearance Adjustment in the Periodic Maintenance chapter.

### Valve Seat Inspection

- Refer to the Valve Seat Inspection in the Periodic Maintenance chapter.

### Valve Seat Repair

- Refer to the Valve Seat Repair in the Periodic Maintenance chapter.

### Valve Head Thickness

- Remove the valve (see Valve Mechanism Removal/Installation).
- Measure the valve head thickness.
- ★ If the valve head thickness (valve margin) [A] is less than the service limit, replace the valve with a new one.

#### Valve Head Thickness

##### Service Limit:

Intake, Exhaust                      **0.35 mm (0.0138 in)**

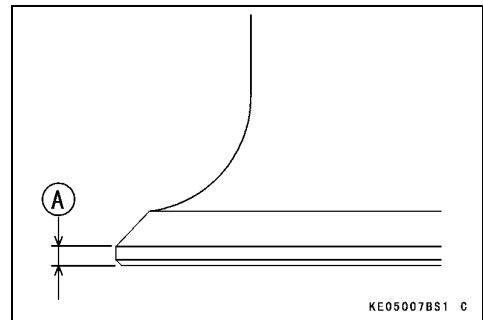

KE05007BS1 C

### Valve Stem Runout

- Support the valve on V blocks at each end of the stem.
- Position a dial gauge perpendicular to the stem.
- Turn the valve and read the variation on the dial gauge.
- ★ If the stem runout is greater than service limit, replace the valve.

#### Valve Stem Runout

##### Service Limit:

Intake, Exhaust                      **TIR 0.05 mm (0.002 in.)**

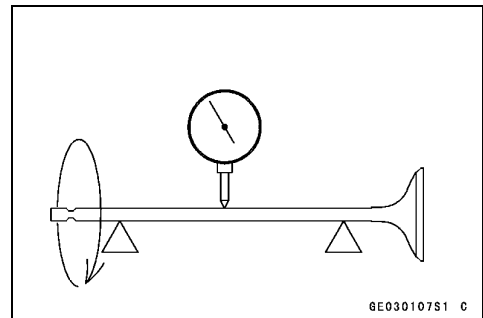

GE030107S1 C

### Valve Stem Diameter

- Measure the diameter of the valve stem [A] in two directions at right angles, at four different positions on the stem.
- ★ If any single measurement is less than the service limit, replace the valve with a new one.

#### Valve Stem Diameter

##### Service Limit:

Intake                      **5.95 mm (0.234 in.)**

Exhaust                      **5.93 mm (0.233 in.)**

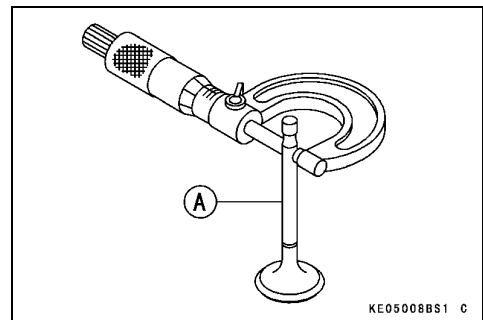

KE05008BS1 C

## 5-16 ENGINE TOP END

### Valves

#### **Valve Guide Inside Diameter**

- Use a small bore gauge or a micrometer to measure the inside diameter [A] of the valve guide [B] at three positions down the guide length.
- ★ If the measurement is more than the service limit, replace the cylinder head with a new one.

#### **Valve Guide Inside Diameter**

##### **Service Limit:**

**Intake, Exhaust 6.08 mm (0.239 in.)**

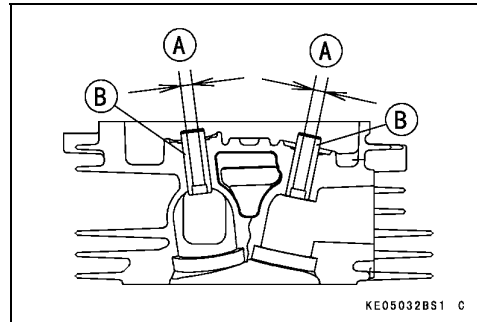

#### **Valve Spring Inspection**

- Inspect the valve spring for pitting, cracks, rusting, and burns. Replace the spring with a new one if necessary.
- Measure the free length [A] of the spring.
- ★ If the measurement is less than the service limit, replace the spring with a new one.

#### **Valve Spring Free Length**

##### **Service Limit:**

**Intake, Exhaust 31.0 mm (1.22 in.)**

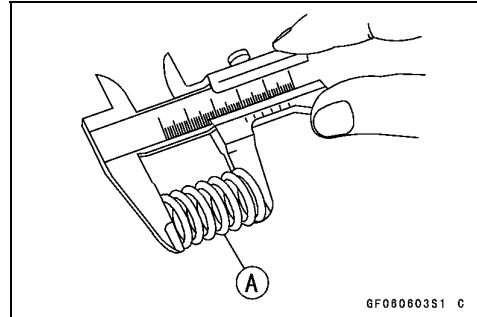

## Cylinder, Piston

### Piston Removal

- Remove:
  - Cylinder Head Assembly (see Cylinder Head Assembly Removal)
  - Crankcase Cover (see Crankcase Cover Removal in the Camshaft/Crankshaft chapter)
  - Camshaft (see Camshaft, Tappet Removal in the Camshaft/Crankshaft chapter)
- Turn the crankshaft to expose the connecting rod cap bolts [A].
- Remove the bolts and take off the connecting rod caps [B].

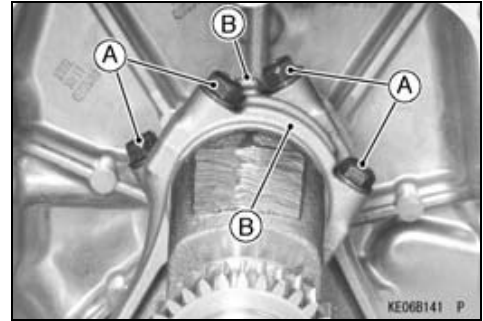

### NOTE

○ Note the positions of the connecting rod caps for re-installing the caps.

- Scrape the carbon deposits from the cylinder head with a suitable tool before the piston and connecting rod are pulled out.
- Push the connecting rod end into the cylinder, and pull the piston and connecting rod out of the cylinder.

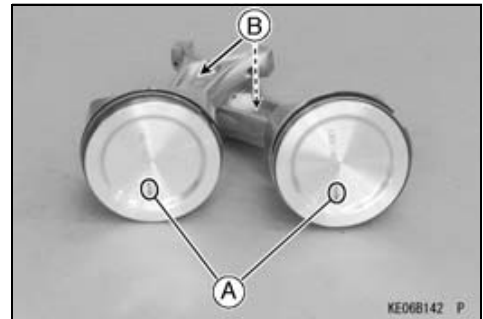

### NOTICE

**Note the location of the arrow match mark [A] on the piston head in relation to "K" Mark [B] on the connecting rod.**

**No.1 cylinder "K" Mark on the connecting rod is face to face with No.2 cylinder "K" Mark on the connecting rod. Keep parts together as a set.**

- Remove one of the piston pin snap rings [A] with needle nose pliers [B].

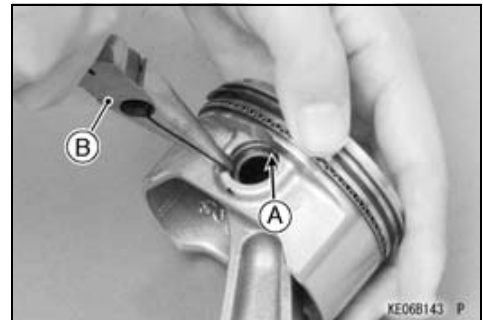

- Remove the piston by pushing the piston pin [A] to the direction from which the snap ring was removed.
- Remove the piston from the connecting rod.



## 5-18 ENGINE TOP END

### Cylinder, Piston

- Remove the top and second rings with piston ring pliers.  
**Special Tool - Piston Ring Pliers: 57001-115**
- If the special tool is not available, carefully spread the ring opening with your thumbs, then push up to the opposite side of the ring [A] to remove it.
- Remove the 3-piece oil ring with your thumbs in the same manner.

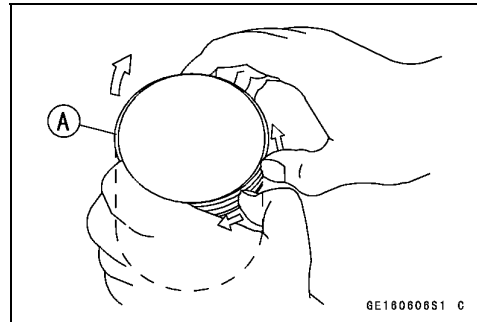

### Piston Installation

- Install the expander [A] in the piston oil ring groove so that the expander ends [B] touch together, never overlap them.
- Install the upper and lower steel rails. There is no UP or Down to the rails. They can be installed either way.

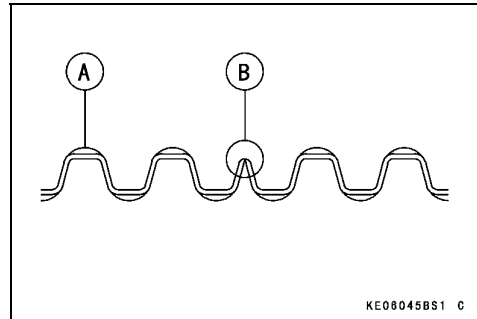

- Do not mix up the top and second rings.
- Install the second ring as follows.  
Replacing with new one:
  - Install the second ring so that the white stripe [A] is on the right side of the end gap.Reassembling the ring in use:
  - Install the second ring so that the notched edge [B] faces upward.
- Install the top ring.
- The rings should turn freely in the grooves.  
Piston Head [C]  
Top Ring [D]  
Second Ring [E]

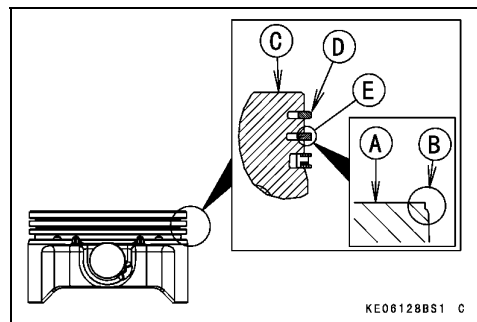

- Align the piston and rings with the piston ring end gap as shown in the figure.  
Arrow Match Marks [A]  
Top Ring End Gap, Upper Steel Rail End Gap [B]  
45° [C]  
Second Ring End Gap, Lower Steel Rail End Gap [D]

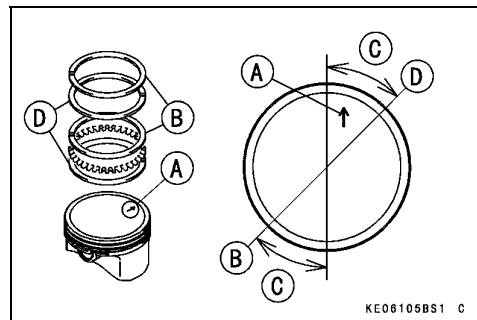

## Cylinder, Piston

- Apply engine oil to the piston pins.
- Assemble the pistons onto the connecting rods as follow.
- No.1 Cylinder Piston; align the arrow mark on the piston head with opposite "K" Mark on the connecting rod to face the flywheel side.
- No.2 Cylinder Piston; align the arrow mark on the piston crown with the "K" mark on the connecting rod.
- Both marks must face the flywheel side.
  - No.1 cylinder Piston [A]
  - No.2 cylinder Piston [B]
  - Arrow Marks [C]
  - "K" Mark [D]
  - Opposite "K" Mark [E]

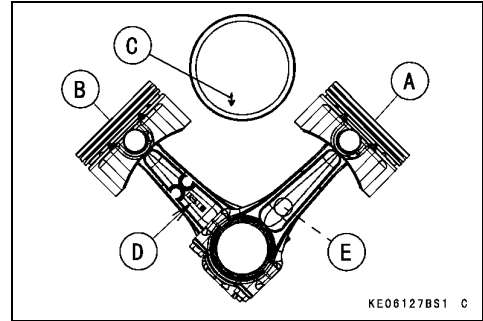

- Fit a new piston pin snap ring into the side of the piston so that the ring opening [A] does not coincide with the notch [B] in the edge of the piston pin hole.
- When installing a piston pin snap ring, compress it only enough to install it and no more.

### NOTICE

**Do not reuse the snap rings, as removal weakens and deforms them. They could fall out and score the cylinder wall.**

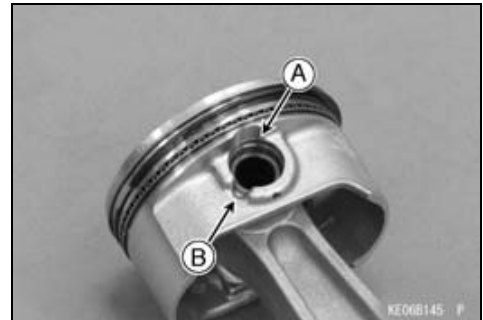

- Apply molybdenum disulfide oil solution to the top [A] and bottom [B] of the inside of the cylinder in 30 mm depth each.
- The molybdenum disulfide oil solution is a mixture of engine oil and molybdenum disulfide grease with a volume ratio (1:1).

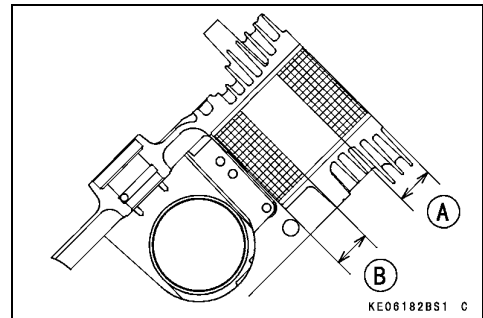

- Using the piston ring compressor grip [A] and the belt [B], lightly tap the top of the piston with a plastic mallet [C] to insert the piston and connecting rod into the cylinder.

**Special Tools - Piston Ring Compressor Grip: 57001-1095**  
**Piston Ring Compressor Belt,  $\phi 67 \sim \phi 79$ : 57001-1097**

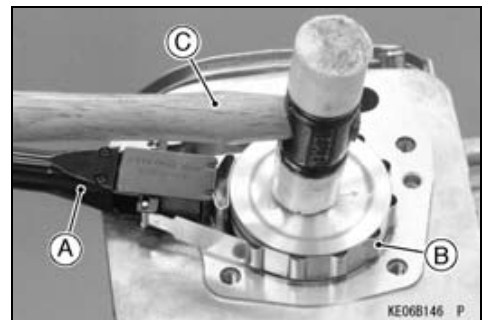

## 5-20 ENGINE TOP END

### Cylinder, Piston

- Insert the piston and connecting rod so that the arrow mark [A] on the top of the piston is facing the flywheel side.

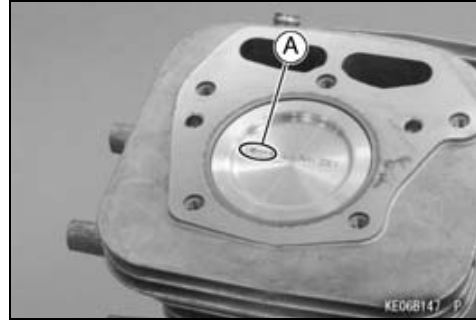

#### NOTICE

The connecting rod and the connecting rod big end cap are machined at the factory in the assembled state, so they must be replaced together as a set.

- Apply molybdenum disulfide oil solution to the inner surface [A] of the connecting rod big end [B] and caps [C].
- The molybdenum disulfide oil solution is a mixture of engine oil and molybdenum disulfide grease with a weight ratio (10:1).
- Install the connecting rod big end caps on their original position on each connecting rod big ends.
- Apply a thin layer of engine oil to the thread [D] and seating surface [E] of the cap bolts.
- Tighten:  
**Torque - Connecting Rod Big End Cap Bolts: 9.8 N·m (1.0 kgf·m, 87 in·lb)**
- Install the removed parts (see appropriate chapters).

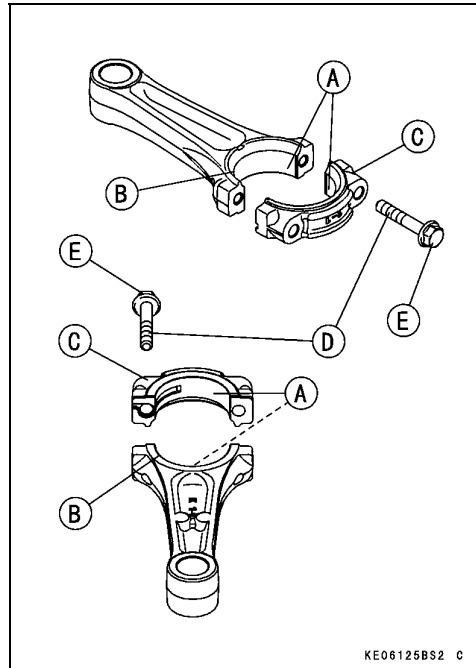

#### Piston/Cylinder Seizure

- In case of seizure, remove the pistons (see Piston Removal).
- Visually inspect the cylinder and pistons for damage.
- ★ If there is only light damage, repair the damaged piston surface with #400 emery cloth. Remove the small aluminum deposits from the cylinder with #400 emery cloth or light honing.
- ★ If the damage is severe, replace the crankcase and pistons.

#### Piston Cleaning

- Remove the piston and piston rings (see Piston Removal).

#### NOTICE

Never clean the piston head with the engine assembled. Carbon particles will fall between the piston and cylinder, and damage the crankshaft bearings.

- Scrape the carbon off the piston head.
- Use the scraping tools [A] carefully. Do not gouge the piston head. To avoid gouging, use scrapers that are made of a material that will not cause damage.

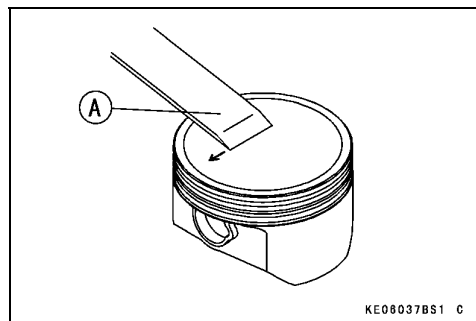

## Cylinder, Piston

- Clean the piston ring grooves [A] with a broken piston ring or other suitable tools.

### NOTICE

**Be careful not to widen the ring grooves. Damaged ring grooves will require piston replacement.**

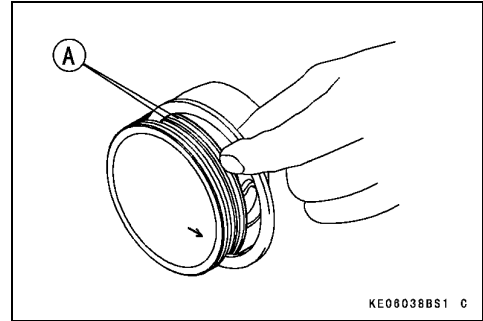

### Piston Ring and Ring Groove Wear

- Clean the piston (see Piston Cleaning).
- Visually inspect the piston rings and ring grooves.
- ★ If the piston rings are worn unevenly or damaged, replace them with new ones.
- ★ If the ring grooves are worn unevenly or damaged, replace both the piston and the piston rings with new ones.
- Measure the clearance between the top and second rings and their grooves using a thickness gauge [A] as shown.
- ★ If the piston ring/groove clearance is greater than the service limit, replace the piston with a new one.

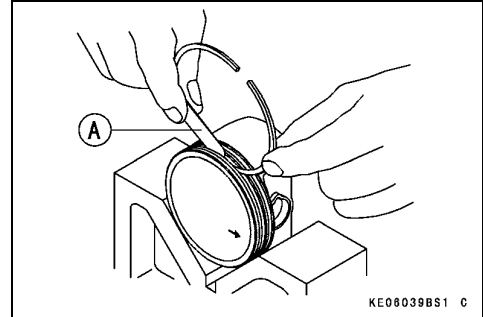

### Piston Ring/Groove Clearance

#### Service Limit:

Top	0.12 mm (0.0047 in.)
Second	0.12 mm (0.0047 in.)

### NOTE

○ The oil ring is a three piece assembled ring. It is difficult to measure the ring groove clearance and thickness, visually inspect only.

- Measure the piston ring thickness [A].
- Use a micrometer to measure at several points around the rings.
- ★ If any of the measurement are less than the service limit, replace the entire set of rings with new ones.

### Piston Ring Thickness

#### Service Limit:

Top	1.1 mm (0.043 in.)
Second	1.1 mm (0.043 in.)

### NOTE

○ When using new rings in a used piston, check for uneven groove wear. The rings should fit perfectly parallel to the groove sides. If not, replace the piston with a new one.

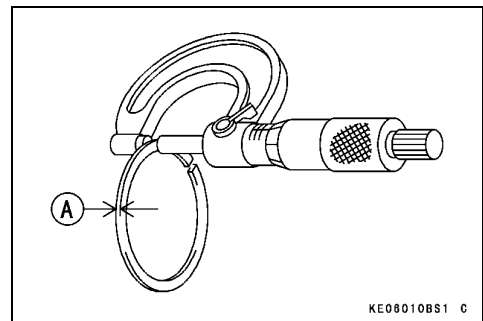

## 5-22 ENGINE TOP END

### Cylinder, Piston

#### **Piston Ring End Gap**

- Remove the piston rings (see Piston Removal).
- Push each ring (one at a time) in the cylinder bore to a point close to the bottom of the cylinder bore.
- Use the piston to push it in to be sure it is square.
- Measure the gap [A] between the ends of the ring [B] with a thickness gauge.
- ★ If the end gap of any ring is greater than the service limit, replace the entire set of rings with new ones.

#### **Piston Ring End Gap**

##### **Service Limit:**

Top	0.7 mm (0.028 in.)
Second	0.9 mm (0.035 in.)
Oil	1.05 mm (0.041 in.)

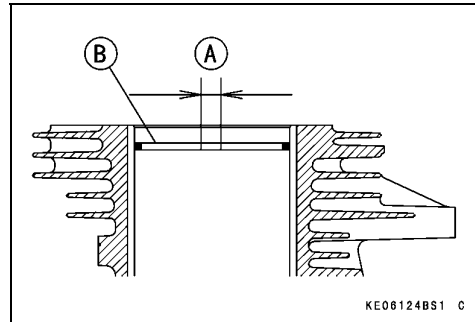

#### **Piston Pin, Piston Pin Hole, and Connecting Rod Wear**

- Remove the piston pin (see Piston Removal).
- Measure the outside diameter of the piston pin with a micrometer at several points.
- ★ If the outside diameter is less than service limit, replace the piston pin with a new one.

#### **Piston Pin Outside Diameter**

**Service Limit: 15.96 mm (0.628 in.)**

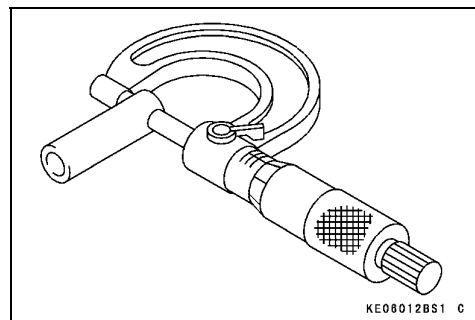

- Measure the inside diameter [A] of the piston pin hole at several points on both side. Use a dial bore gauge.
- ★ If the inside diameter is greater than the service limit, replace the piston with a new one.

#### **Piston Pin Hole Inside Diameter**

**Service Limit: 16.08 mm (0.633 in.)**

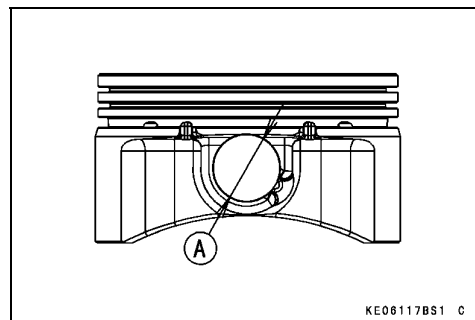

- Measure the inside diameter [A] of the connecting rod small end at several points. Use a dial bore gauge.
- ★ If the inside diameter is more than the service limit, replace the connecting rod with a new one.

#### **Connecting Rod Small End Inside Diameter**

**Service Limit: 16.05 mm (0.632 in.)**

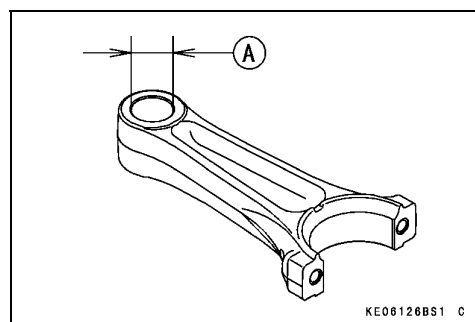

## Cylinder, Piston

### Piston Diameter

- Measure the outside diameter [A] of the piston 11 mm (0.43 in.) [B] up from the bottom of the piston at a right angle to the direction of the piston pin hole.
- ★ If the measurement is less than the service limit, replace the piston with a new one.

#### Piston Diameter

Service Limit: 72.79 mm (2.866 in.)

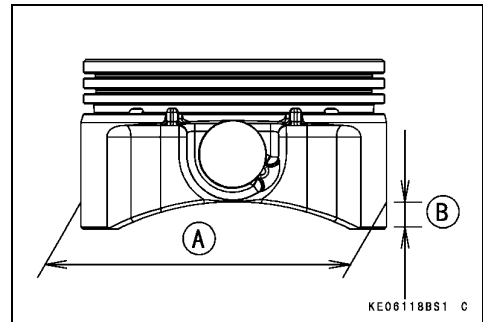

### Cylinder Inside Diameter

- Clean and measure the cylinder inside diameter.
- Use a cylinder gauge to measure front-to-back and side-to-side at the points as shown in the figure.
- ★ If any of the cylinder inside diameter measured value is greater than the service limit, the cylinder must be bored to the next oversize and then hored (see Cylinder Boring and Honing).
  - 10 mm (0.39 in.) [A]
  - 40 mm (1.6 in.) [B]
  - 25 mm (0.98 in.) [C]

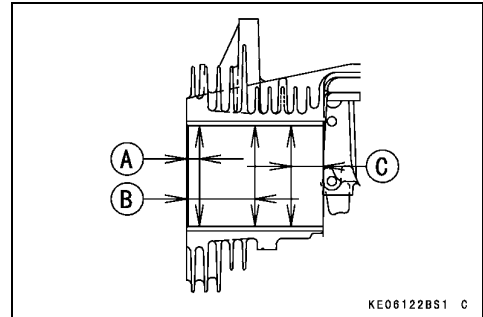

#### Cylinder Inside Diameter

##### Standard:

Standard Cylinder	72.98 ~ 73.00 mm (2.873 ~ 2.874 in.)
0.50 mm Oversize	73.48 ~ 73.50 mm (2.893 ~ 2.894 in.)

##### Service Limit:

Standard Cylinder	73.10 mm (2.878 in.)
0.50 mm Oversize	73.60 mm (2.898 in.)

#### Cylinder Bore Out Round

Service Limit: 0.05 mm (0.002 in.)

### Cylinder Boring and Honing

Always resize to exactly 0.5 mm (0.02 in.) over the standard bore size. If this is done accurately, the stock oversize rings and piston will fit perfectly and proper clearance will be maintained. Resizing the cylinder bore can be done by reliable repair shop or by using a drill press and honing tool. Use the stone recommended by the hone manufacturer to produce correct cylinder wall finish. Machine-bore first, the bore diameters should be shown in the table.

#### Boring Inside Diameter

Oversize	Inside Bore Diameter
0.50 mm	73.46 ~ 73.48 mm (2.892 ~ 2.893 in.)

#### Honing Inside Diameter

Oversize	Inside Diameter
0.50 mm	73.48 ~ 73.50 mm (2.893 ~ 2.894 in.)

## 5-24 ENGINE TOP END

---

### Cylinder, Piston

---

Change to a honing stone for finishing, the final bore diameter should be as shown in the table. Be sure the correct stone is used and the stone is not worn.

- Clean the cylinder at the top and bottom of the cylinder to remove burrs and pieces of the base and head gasket.
- Anchor the cylinder (block) on the drill press table before honing.
- Align the center of the cylinder bore to the press center. Set the press to operate from 200 ~ 250 rpm.
- Connect the drive shaft to the hone and set the stop on the drill press so the hone can only extend 20 ~ 25 mm (0.8 ~ 1.0 in.) above the top or below the bottom of the cylinder liner.
- Rotate the adjusting nut (knob) on the hone until the stones contact snugly against the cylinder wall at the narrowest point. Do not force.
- Turn the stone by hand. If you cannot turn it, the stone is too tight. Loosen the hone until it can be turned by hand.
- Be sure that the cylinder and hone are centered and aligned with the drive shaft and drill spindle.
- Pour honing oil inside of the cylinder during the honing operation. Start the drill press. Move the hone up and down in the cylinder approximately 20 cycles-per-minute.
- Check the diameter of the cylinder bore regularly during honing, using an inside micrometer.

# Lubrication System

## Table of Contents

- Exploded View ..... 6-2
- Engine Oil Flow Chart..... 6-4
- Specifications ..... 6-5
- Special Tools ..... 6-6
- Engine Oil and Oil Filter..... 6-7
  - Engine Oil Level Inspection ..... 6-7
  - Engine Oil Change..... 6-7
  - Oil Filter Removal ..... 6-7
  - Oil Filter Installation ..... 6-7
- Pressurized Lubrication System ..... 6-8
  - Oil Pressure Measurement ..... 6-8
- Oil Pump, Relief Valve ..... 6-9
  - Oil Pump, Relief Valve Removal ..... 6-9
  - Oil Pump, Relief Valve Installation ..... 6-9
  - Oil Pump, Relief Valve Inspection ..... 6-9
- Oil Screen..... 6-11
  - Oil Screen Removal ..... 6-11
  - Oil Screen Installation ..... 6-11
  - Cleaning and Inspection ..... 6-11



# 6-2 LUBRICATION SYSTEM

## Exploded View

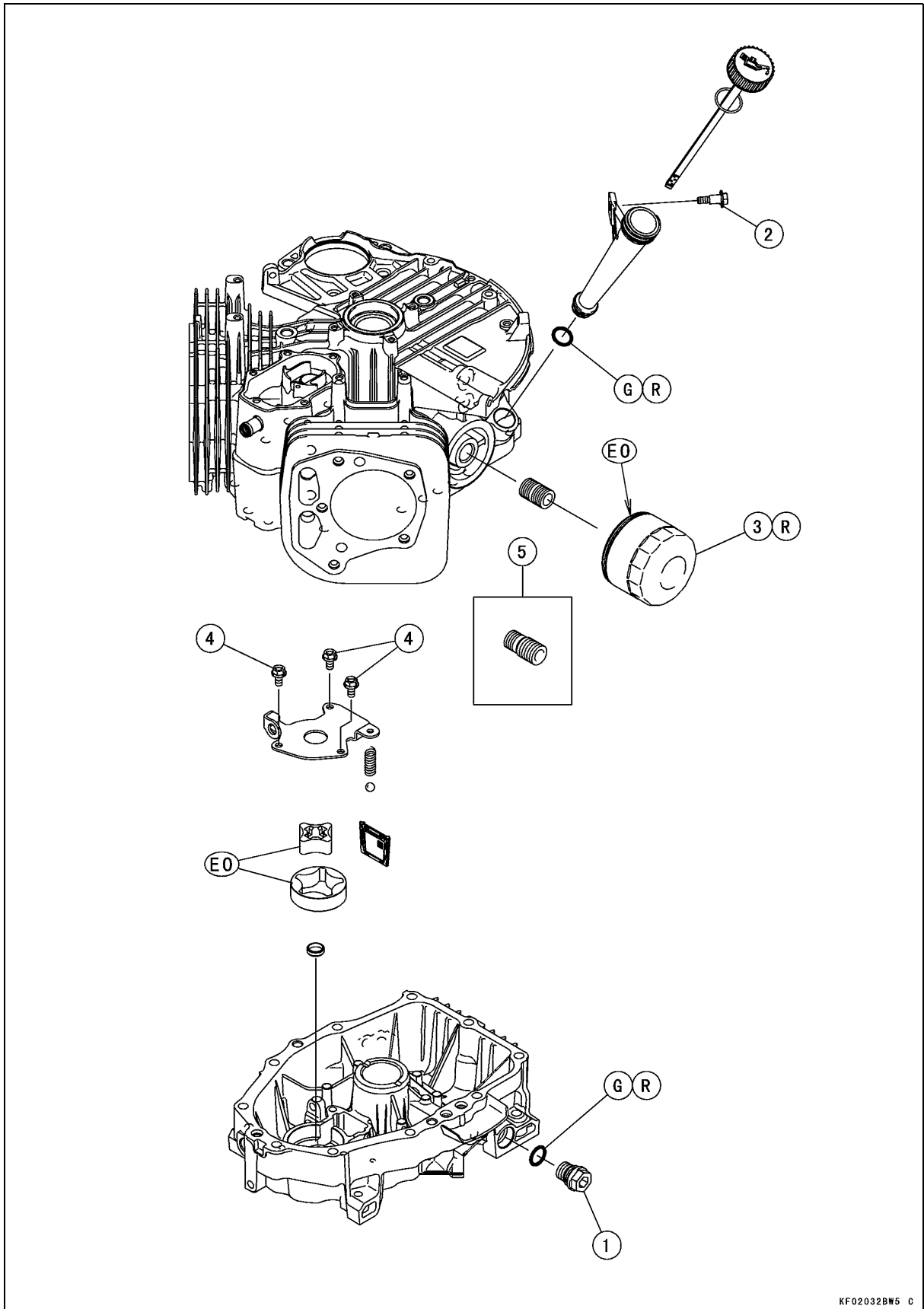

**LUBRICATION SYSTEM 6-3**

**Exploded View**

No.	Fastener	Torque			Remarks
		N·m	kgf·m	ft·lb	
1	Engine Oil Drain Plug	6.9	0.70	61 in·lb	
2	Oil Filler Mounting Bolt	8.8	0.90	78 in·lb	
3	Oil Filter	11.8	1.2	104 in·lb	R
4	Oil Pump Cover Plate Bolts	5.9	0.60	52 in·lb	

5. FX481/541/600V-AS00 and FS481/541/600V-AS00 ~ BS00 Models  
EO: Apply engine oil.  
G: Apply grease.  
R: Replacement Parts

# 6-4 LUBRICATION SYSTEM

## Engine Oil Flow Chart

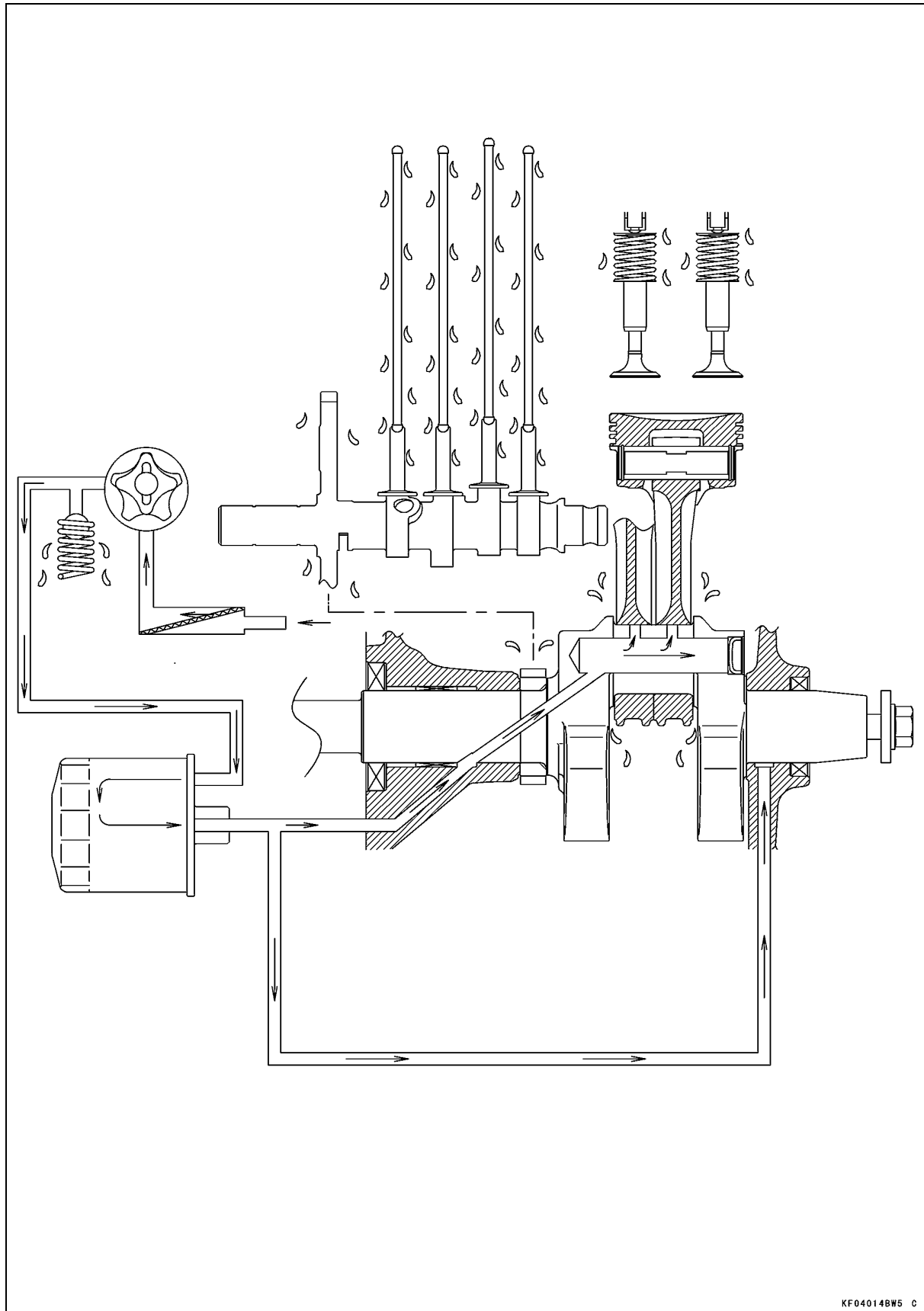

**Specifications**

Item	Standard
<b>Engine Oil</b> Grade Viscosity Capacity: When the oil filter is not removed When the oil filter is removed Level	SJ or higher class SAE40, SAE30, SAE10W-30/SAE10W-40, or SAE5W-20 1.5 L (1.6 US qt) 1.7 L (1.8 US qt) Operating range (grid area (ADD and FULL)) on dipstick
<b>Oil Pressure</b>	294 to 686 kPa (43 to 99 psi): Engine oil temperature 50°C to 60°C (122 ~ 144°F) @3 200 r/min (rpm)

Item	Service Limit
<b>Oil Pump</b> Inner and Outer Rotor Clearance Outer Rotor Outside Diameter Outer Rotor Thickness Pump Housing Inside Diameter Pump Housing Depth Relief Valve Spring Free Length	0.2 mm (0.008 in.) 52.31 mm (2.059 in.) 14.91 mm (0.5870 in.) 52.72 mm (2.076 in.) 15.16 mm (0.5968 in.) 20.4 mm (0.803 in.)

## 6-6 LUBRICATION SYSTEM

### Special Tools

Oil Pressure Gauge, 10 kgf/cm<sup>2</sup>:  
57001-164

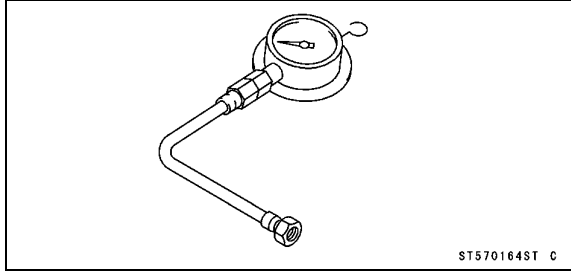

Oil Pressure Gauge Adapter, PT 1/8:  
57001-1033

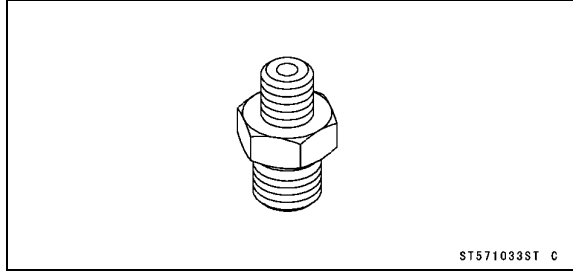

---

### Engine Oil and Oil Filter

---

<b><i>NOTICE</i></b>
----------------------

<b>Engine operation with insufficient, deteriorated, or contaminated engine oil will cause accelerated wear and may result in engine seizure and accident.</b>
--

#### ***Engine Oil Level Inspection***

- Refer to the Engine Oil Level Inspection in the Periodic Maintenance chapter.

#### ***Engine Oil Change***

- Refer to the Engine Oil Change in the Periodic Maintenance chapter.

#### ***Oil Filter Removal***

- Refer to the Oil Filter Replacement in the Periodic Maintenance chapter.

#### ***Oil Filter Installation***

- Refer to the Oil Filter Replacement in the Periodic Maintenance chapter.

## 6-8 LUBRICATION SYSTEM

### Pressurized Lubrication System

The engine lubrication circuit is a pressurized system consisting of a positive displacement pump which picks up oil through a filter screen from the crankcase. The oil is pumped to a replaceable oil filter cartridge, through the engine's oil passages to lubricate internal components, and return to the crankcase. A pressure relief valve is used between the oil pump and oil filter to relieve excessive oil pressure by returning excess oil to the crankcase (see Oil Flow Chart).

#### **Oil Pressure Measurement**

- Remove the oil passage plug [A] from the crankcase.

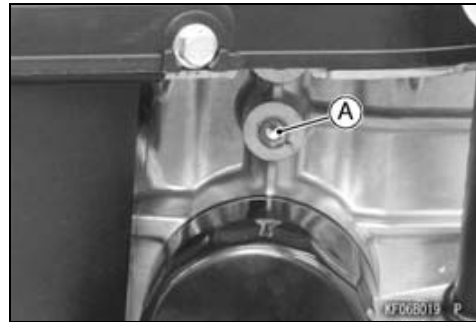

- Install the oil pressure gauge adapter [A] and oil pressure gauge [B].

**Special Tools - Oil Pressure Gauge, 10 kgf/cm<sup>2</sup>: 57001-164**  
**Oil Pressure Gauge Adapter, PT 1/8: 57001-1033**

- Run the engine and warm up thoroughly.
- Run the engine at 3 200 r/min (rpm) and read the oil pressure gauge.
- ★ If the oil pressure is below the specification, inspect the oil pump and relief valve (see Oil Pump, Relief Valve Inspection).
- ★ If the oil pump and relief valve are not at fault, inspect the rest of the lubrication system.

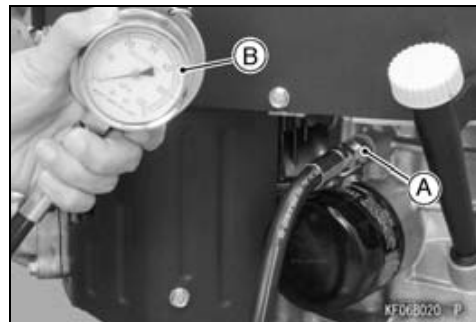

#### **Oil Pressure**

**294 to 686 kPa (43 to 99 psi)**

#### **Measurement Condition**

**Engine Oil Temperature: 50 ~ 60°C (122 ~ 144°F)**

**Engine Speed: 3 200 r/min (rpm)**

- Stop the engine.
- Remove the oil pressure gauge and adapter.

#### **⚠ WARNING**

**Hot oil can cause severe burns. Beware of hot engine oil that will drain through the oil passage when the gauge adapter is removed.**

- Apply a non-permanent locking agent to the oil passage plug, and tighten it.

**Torque - Oil Passage Plug: 3.9 N·m (0.40 kgf·m, 35 in·lb)**

## Oil Pump, Relief Valve

### Oil Pump, Relief Valve Removal

- Remove:
  - Crankcase Cover (see Crankcase Cover Removal in the Camshaft/Crankshaft chapter)
  - Governor Shaft (see Governor Shaft Removal in the Fuel System chapter)
  - Bolts [A]
  - Pump Cover Plate [B]

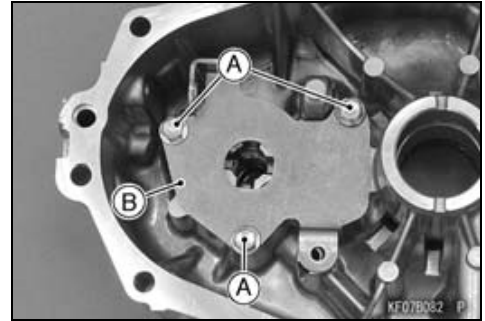

- Remove:
  - Inner Rotor [A]
  - Outer Rotor [B]
  - Spring [C]
  - Relief Valve Ball [D]

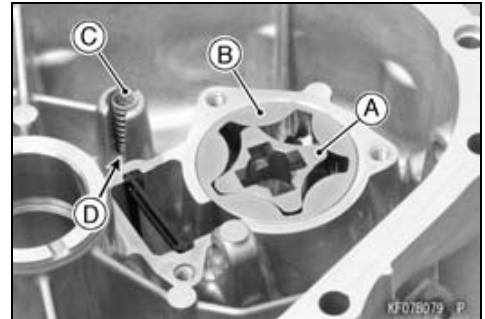

### Oil Pump, Relief Valve Installation

- Fill the rotor housing with engine oil for initial lubrication.
- Install the outer [A] and inner rotor [B].
- Align the inner rotor groove [C] to the center of the crankcase cover as shown in the figure.
- Install the relief valve ball and spring in position.
- Install the pump cover plate.
- Tighten:

**Torque - Oil Pump Cover Plate Bolts: 5.9 N·m (0.60 kgf·m, 52 in·lb)**

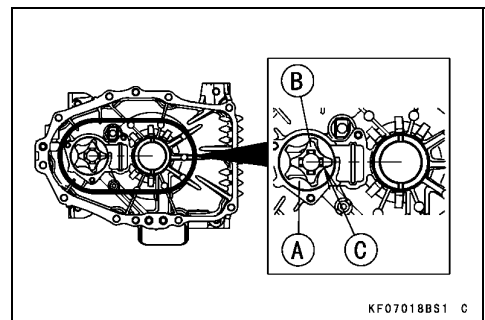

### Oil Pump, Relief Valve Inspection

- Remove the pump cover plate (see Oil Pump, Relief Valve Removal).
- Visually inspect the pump gear, outer and inner rotor, and cover plate.
- ★ If there is any damage or uneven wear, replace them with new ones.
- Check the clearance [A] between the inner and outer rotor with a feeler gauge. Measure the clearance between the high point of the inner rotor and the high point of the outer rotor.
- ★ If the measurement exceed the service limit, replace the rotors as a set with new ones.

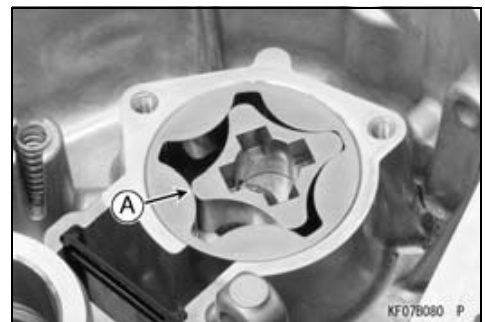

#### Inner and Outer Rotor Clearance

**Service Limit: 0.2 mm (0.008 in.)**

## 6-10 LUBRICATION SYSTEM

### Oil Pump, Relief Valve

- Measure the outside diameter [A] of the outer rotor with a micrometer at several points.
- ★ If the rotor diameter is less than the service limit, replace both the inner and outer rotor with new ones.

#### Outer Rotor Outside Diameter

**Service Limit: 52.31 mm (2.059 in.)**

- Measure the thickness [B] of the outer rotor with a micrometer at several points.
- ★ If the rotor thickness is less than the service limit, replace both the inner and outer rotor with new ones.

#### Outer Rotor Thickness

**Service Limit: 14.91 mm (0.5870 in.)**

- Measure the inside diameter [A] of the pump housing with an inside micrometer at several points.
- ★ If the inside diameter is more than the service limit, replace the crankcase cover with a new one.

#### Pump Housing Inside Diameter

**Service Limit: 52.72 mm (2.076 in.)**

- Measure the depth [B] of the pump housing with a depth micrometer at several points.
- ★ If any of measurement is more than the service limit, replace the crankcase cover with a new one.

#### Pump Housing Depth

**Service Limit: 15.16 mm (0.5968 in.)**

- Visually inspect the relief valve spring, steel ball and valve seat in the crankcase cover.
- ★ If any rough spot is found during above inspection, wash the valve clean with a high flash-point solvent and blow out any foreign particles on the valve with compressed air.

### **⚠ WARNING**

**Gasoline and low flash-point solvents can be flammable and/or explosive and cause severe burns. Clean the parts in a well-ventilated area, and take care that there is no spark or flame anywhere near the working areas. Do not use gasoline or low flash-point solvents to clean parts.**

- ★ If cleaning does not solve the problem, replace the relief valve parts with new ones.
- ★ If necessary, put the ball in position and lightly tap the ball with a suitable tool to form a perfect seat.
- Measure the free length [A] of the spring with a vernier caliper.
- ★ If the free length of the spring is less than the service limit, replace the spring with a new one.

#### Relief Valve Spring Free Length

**Service Limit: 20.4 mm (0.803 in.)**

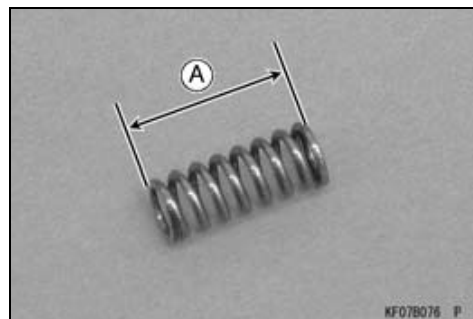
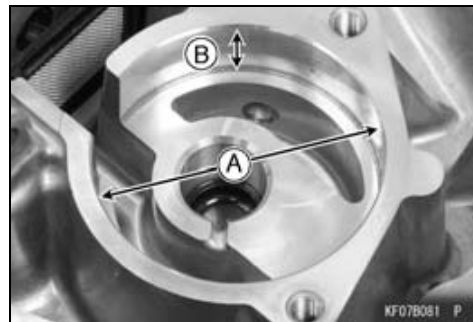
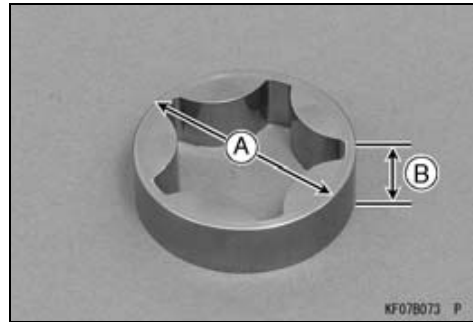

## Oil Screen

### Oil Screen Removal

- Remove the oil pump cover plate (see Oil Pump, Relief Valve Removal).
- Remove the oil screen [A].



### Oil Screen Installation

- Clean the oil screen thoroughly whenever it is removed for any reason (see Cleaning and Inspection).
- Insert the oil screen [A] in position.
- Install the oil pump cover plate (see Oil Pump, Relief Valve Installation).



### Cleaning and Inspection

- Clean the oil screen [A] with high flash-point solvent and remove any particles stuck to it.

#### **⚠ WARNING**

**Gasoline and low flash-point solvents can be flammable and/or explosive and cause severe burns. Clean the parts in a well-ventilated area, and take care that there is no spark or flame anywhere near the working areas. Do not use gasoline or low flash-point solvents to clean parts.**

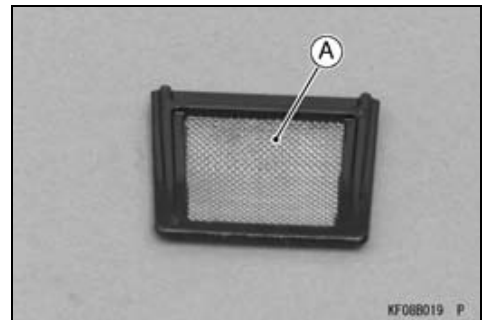

#### **NOTE**

- *While cleaning the screen, check for any metal particles that might indicate internal engine damage.*
- Check the screen carefully for any damage: holes and broken wire.
- ★ If the screen is damaged, replace it with a new one.



# Camshaft/Crankshaft

## Table of Contents

Exploded View.....	7-2
Specifications .....	7-4
Special Tool .....	7-5
Crankcase .....	7-6
Crankcase Cover Removal.....	7-6
Crankcase Cover Disassembly.....	7-6
Crankcase Cover Assembly.....	7-7
Crankcase Cover Installation.....	7-7
Crankcase Cover Inspection.....	7-8
Crankcase Disassembly .....	7-8
Crankcase Assembly .....	7-9
Crankcase Inspection .....	7-9
Crankcase and Crankcase Cover Cleaning.....	7-10
Breather.....	7-11
Breather Valve Removal .....	7-15
Breather Valve Installation .....	7-15
Breather Valve Inspection .....	7-16
Breather Pipe Removal.....	7-16
Breather Pipe Installation.....	7-16
Camshaft, Tappet .....	7-17
Camshaft, Tappet Removal.....	7-17
Camshaft, Tappet Installation.....	7-17
Camshaft Disassembly .....	7-17
Camshaft Assembly .....	7-18
Camshaft Inspection .....	7-18
Camshaft Bearing/Journal Wear .....	7-18
Crankshaft, Connecting Rod .....	7-20
Connecting Rod Removal.....	7-20
Connecting Rod Installation.....	7-20
Crankshaft Removal .....	7-20
Crankshaft Installation .....	7-20
Cleaning/Inspection .....	7-20
Connecting Rod Bend/Twist.....	7-21
Connecting Rod Big End/Crankpin Width Wear .....	7-21
Connecting Rod Big End Bearing/Crankpin Wear .....	7-22
Crankshaft Runout.....	7-22
Crankshaft Main Journal/Wear .....	7-23

# 7-2 CAMSHAFT/CRANKSHAFT

## Exploded View

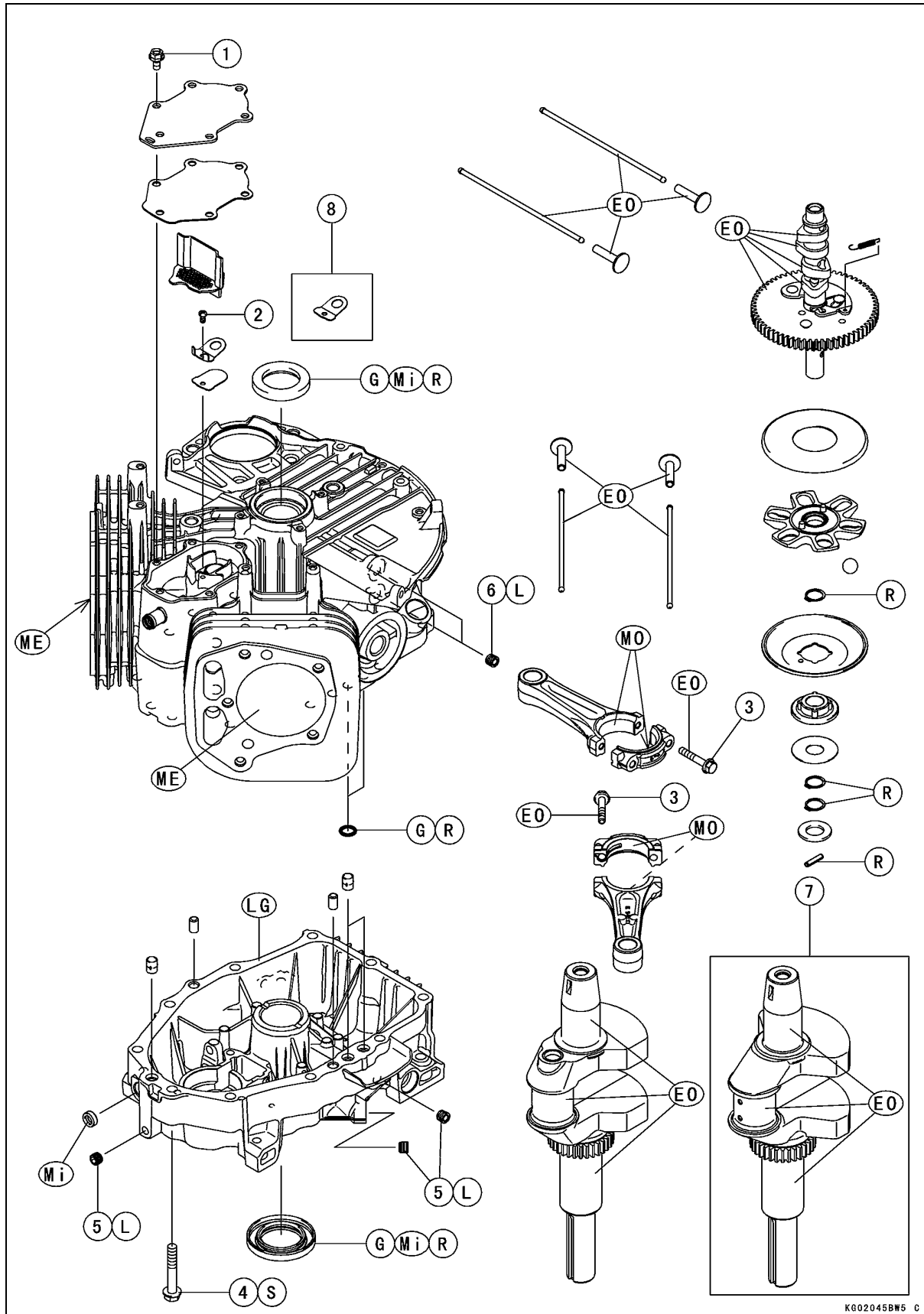

## Exploded View

No.	Fastener	Torque			Remarks
		N·m	kgf·m	ft·lb	
1	Breather Chamber Cover Bolts	5.9	0.60	52 in·lb	
2	Breather Valve Mounting Screw	2.0	0.20	18 in·lb	
3	Connecting Rod Big End Cap Bolts	9.8	1.0	87 in·lb	EO
4	Crankcase Cover Bolts	27.4	2.8	20	S
5	Crankcase Cover Oil Passage Plugs	3.9	0.40	35 in·lb	L
6	Crankcase Oil Passage Plugs	3.9	0.40	35 in·lb	L

7. FR Models

8. FR541/600V-AS00 ~ CS00 Models

EO: Apply engine oil.

G: Apply grease.

L: Apply a non-permanent locking agent.

Mi: Apply mineral oil.

ME: Apply molybdenum disulfide oil.

(mixture of the engine oil and molybdenum disulfide grease in a volume ratio 1:1)

MO: Apply molybdenum disulfide oil.

(mixture of the engine oil and molybdenum disulfide grease in a weight ratio 10:1)

R: Replacement Parts

S: Tighten the fasteners following the specified sequence.

## 7-4 CAMSHAFT/CRANKSHAFT

### Specifications

Item	Service Limit
<b>Camshaft, Tappet</b> Cam Lobe Height: Intake Exhaust Camshaft Journal Diameter: PTO Side Flywheel Side Camshaft Bearing Inside Diameter: Crankcase Crankcase Cover	   29.62 mm (1.166 in.) 29.62 mm (1.166 in.)  15.99 mm (0.630 in.) 15.99 mm (0.630 in.)  16.14 mm (0.635 in.) 16.14 mm (0.635 in.)
<b>Crankshaft, Connecting Rod</b> Connecting Rod Bend Connecting Rod Twist Connecting Rod Big End Width Crankpin Width Connecting Rod Big End Inside Diameter Crankpin Outside Diameter Crankshaft Runout Crankshaft Journal Diameter PTO Side Flywheel Side	TIR 0.15/100 mm (0.006/3.94 in.) TIR 0.15/100 mm (0.006/3.94 in.) 19.00 mm (0.748 in.) 40.0 mm (1.57 in.) 38.04 mm (1.498 in.) 37.94 mm (1.494 in.) TIR 0.05 mm (0.002 in.)  37.90 mm (1.492 in.) 34.90 mm (1.374 in.)
<b>Crankcase</b> Crankshaft Bearing Inside Diameter: Crankcase Crankshaft Journal Bearing Inside Diameter: Crankcase Cover	  35.10 mm (1.382 in.)  38.10 mm (1.500 in.)

**Special Tool**

**Bearing Driver Set:  
57001-1129**

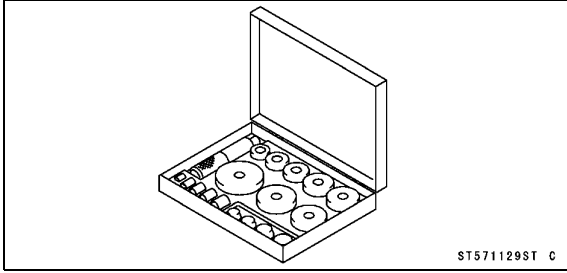

**Gasket-Liquid, TB1217H:  
92104-7001**

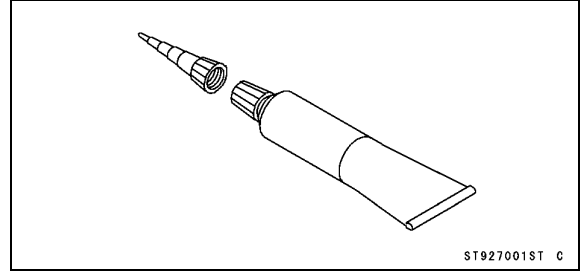

## 7-6 CAMSHAFT/CRANKSHAFT

### Crankcase

#### **Crankcase Cover Removal**

- Set the engine on a clean surface while parts are being removed.
- Drain the engine oil (see Engine Oil Change in the Periodic Maintenance chapter).
- Remove:
  - Oil Filter (see Oil Filter Replacement in the Periodic Maintenance chapter)
  - Intake Manifold (see Intake Manifold Removal in the Fuel System chapter)
  - Engine Shrouds (see Engine Shroud Removal in the Cooling System chapter)
  - Ignition Coils (see Ignition Coil Removal in the Electrical System chapter)
  - Flywheel and Stator Coil (see Flywheel and Stator Coil Removal in the Electrical System chapter)
  - Starter Motor (see Starter Motor Removal in the Starter System chapter) (Electric Starter Model only)
  - Governor Arm (see Governor Arm Removal in the Fuel System chapter)
- Unscrew the mounting bolts in the order shown [1 to 10] and remove the crankcase cover from the crankcase.
- There are two dowel pins on the crankcase mating surface. Using a wooden or plastic mallet, gently tap crankcase to loosen the crankcase cover.

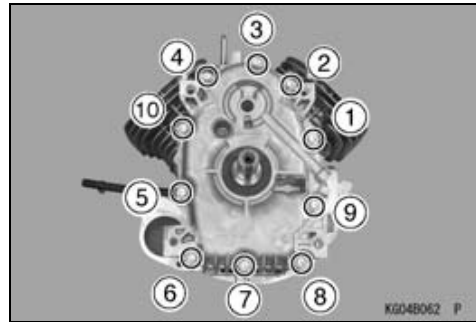

#### **Crankcase Cover Disassembly**

- Remove:
  - Crankcase Cover (see Crankcase Cover Removal)
  - Governor Shaft (see Governor Shaft Removal in the Fuel System chapter)
- Pry the governor shaft oil seal [A] with the suitable tool, and remove it.
- Pry the crankshaft oil seal [A] with the suitable tool, and remove it.

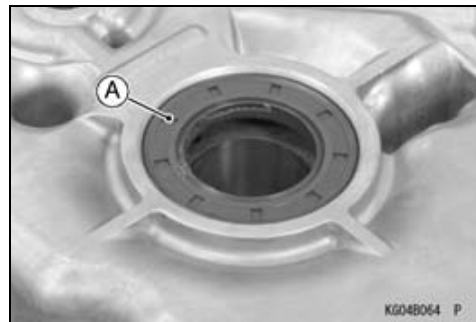
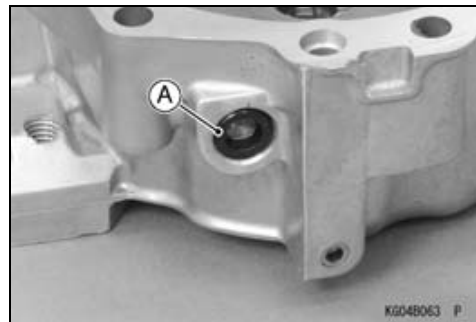

## Crankcase

### Crankcase Cover Assembly

- Chip the old gasket from the mating surfaces of the crankcase and cover.
- Using compressed air, blow out the oil passage in the crankcase cover.
- With a high flash-point solvent, clean off the mating surfaces of the crankcase and the cover, and wipe them dry.

#### **⚠ WARNING**

**Gasoline and low flash-point solvents can be flammable and/or explosive and cause severe burns. Clean the crankcase and cover in a well-ventilated area, and take care that there is no spark or flame anywhere near the working areas. Do not use gasoline or low flash-point solvents to clean parts.**

- Be sure to replace the oil seal with a new one if removed.
- Apply mineral oil to the crankshaft oil seal outside.
- Install the oil seal so that the marks [A] face out.
- Thoroughly pack high-temperature grease to 60% volume into the space [B] between the seal lip [C] and dust lip [D]. Press in the new oil seal using a press or suitable tools until it is flush with flange surface [E] or maximum 1 mm (0.04 in.) [F] lower than the flange surface. Do not damage the seal lip.

PTO Side [G]

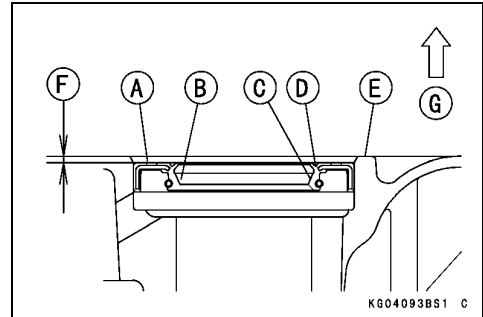

- When replacing the oil seal [A] of the governor shaft, note the following.
- Apply mineral oil to the lip surface of the governor shaft oil seal.
- Install the oil seal into the crankcase cover [B] with a suitable tool after inserted the governor shaft [C] in the crankcase cover, and so that the marks [D] face out. Do not damage the seal lip.
- The depth is 0 ~ 2 mm (0 ~ 0.08 in.) [E].
- Install the governor shaft and plate (see Governor Shaft Installation in the Fuel System chapter).
- Install the crankcase cover (see Crankcase Cover Installation).

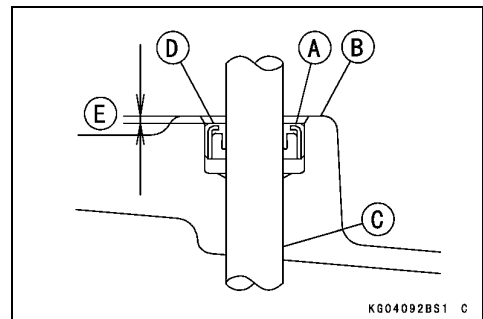

### Crankcase Cover Installation

- Align the inner rotor groove to the center of the crankcase cover (see Oil Pump, Relief Valve Installation in the Lubrication System chapter).
- Apply liquid gasket [A] to the mating surface of the crankcase cover.

**Sealant - Gasket-Liquid, TB1217H: 92104-7001**

#### **NOTE**

- Make the application finish within 5 minutes when the liquid gasket to the mating surface of the crankcase cover is applied.
- Moreover fit the case and tighten the cover bolts just after finishing the application of the liquid gasket.

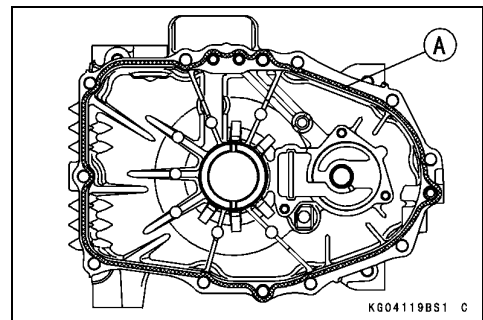

## 7-8 CAMSHAFT/CRANKSHAFT

### Crankcase

- Check to see that the dowel pins [A], O-rings [B] and plastic pipe [C] are in place on the crankcase.

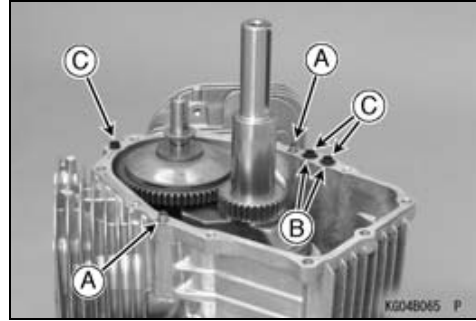

- Install the crankcase cover and tighten the crankcase cover bolts following the tightening sequence as shown in the figure.

**Torque - Crankcase Cover Bolts: 27.4 N·m (2.8 kgf·m, 20 ft·lb)**

- Do not turn one screw down completely before the others, as it may cause the crankcase cover to warp.
- Install the removed parts (see appropriate chapters).

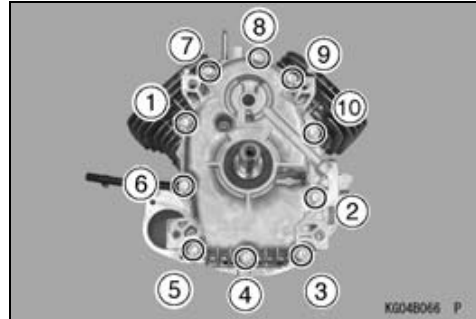

### ***Crankcase Cover Inspection***

- Measure the inside diameter [A] of the crankshaft journal bearing on the crankcase cover at several points. Replace the crankcase cover if the inside diameter is more than the service limit.

**Crankshaft Journal Bearing Inside Diameter**  
**Service Limit: 38.10 mm (1.500 in.)**



### ***Crankcase Disassembly***

- Remove:
  - Crankcase Cover (see Crankcase Cover Removal)
  - Camshaft and Tappets (see Camshaft, Tappet Removal)
  - Crankshaft (see Crankshaft Removal)
- Pry the crankshaft oil seal [A] with the suitable tool, and remove it.

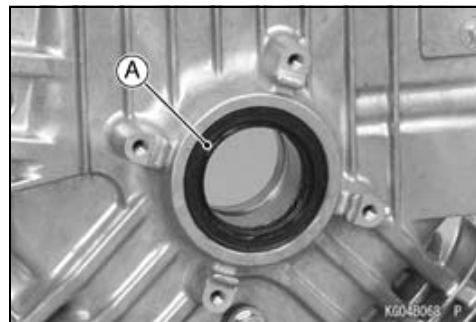

## Crankcase

### Crankcase Assembly

- Remove the old gasket from the mating surfaces of the crankcase and cover.
- Using compressed air, blow out the oil passage in the crankcase.
- With a high flash-point solvent, clean off the mating surfaces of the crankcase and the cover, and wipe them dry.

### **⚠ WARNING**

**Gasoline and low flash-point solvents can be flammable and/or explosive and cause severe burns. Clean the crankcase and cover in a well-ventilated area, and take care that there is no spark or flame anywhere near the working areas. Do not use gasoline or low flash-point solvents to clean parts.**

- Be sure to replace any oil seal with a new one if removed.
- Apply mineral oil to the crankshaft oil seal outside.
- Install the oil seal so that the marks [A] face out.
- Thoroughly pack high-temperature grease to 60% volume into the space [B] between the seal lip [C] and dust lip [D]. Press in the new oil seal using a press or suitable tools until it is flush with flange surface [E] or maximum 1 mm (0.04 in.) [F] lower than the flange surface. Do not damage the seal lip.
- Flywheel Side [G]
- Install the removed parts (see appropriate chapters).

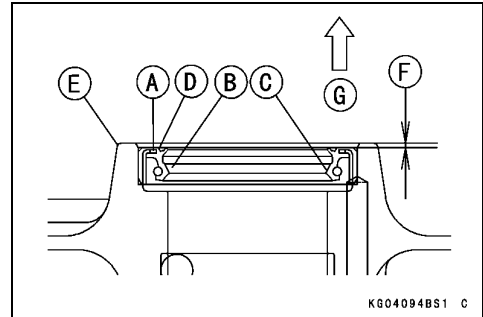

### Crankcase Inspection

- Measure the inside diameter [A] of the crankshaft insert on the crankcase at several points. Replace the crankcase if the inside diameter is more than the service limit.

#### Crankshaft Bearing Inside Diameter

**Service Limit: 35.10 mm (1.382 in.)**



## 7-10 CAMSHAFT/CRANKSHAFT

---

### Crankcase

---

#### ***Crankcase and Crankcase Cover Cleaning***

- Remove:
  - Oil Pump and Relief Valve (see Oil Pump, Relief Valve Removal in the Lubrication System chapter)
  - Camshaft and Tappets (see Camshaft, Tappet Removal)
  - Crankshaft (see Crankshaft Removal)
  - Breather Valve and Cover (see Breather Valve Removal)
- Clean up the crankcase and cover with a high flash-point solvent, and blow out any foreign particles that may be in the pockets inside of the crankcase with compressed air.

 <b>WARNING</b>
--

<p><b>Gasoline and low flash-point solvents can be flammable and/or explosive and cause severe burns. Clean the crankcase and cover in a well-ventilated area, and take care that there is no spark or flame anywhere near the working areas. Do not use gasoline or low flash-point solvents to clean parts.</b></p>
---

## Breather

The function of the breather is to create a negative pressure in the crankcase which prevents oil from being forced out of the engine through the piston rings, oil seals or gaskets. A sealed-type crankcase emission control system is used to prevent blow-by gases from emitting in the air. The blow-by gases are led to the breather chamber through the crankcase and camshaft. Then, it is drawn into the clean side of the air cleaner through the cylinder head and hose and mixed with the clean air flow, and subsequently comes into the combustion chamber through the carburetor and intake manifold.

Oil is primarily separated from the gases while passing through the inside of the rocker chamber from the crankcase, and secondly separated from the gases in the breather chamber, and then returned back to the crankcase cover.

### Electric Starter Model (FX Models)

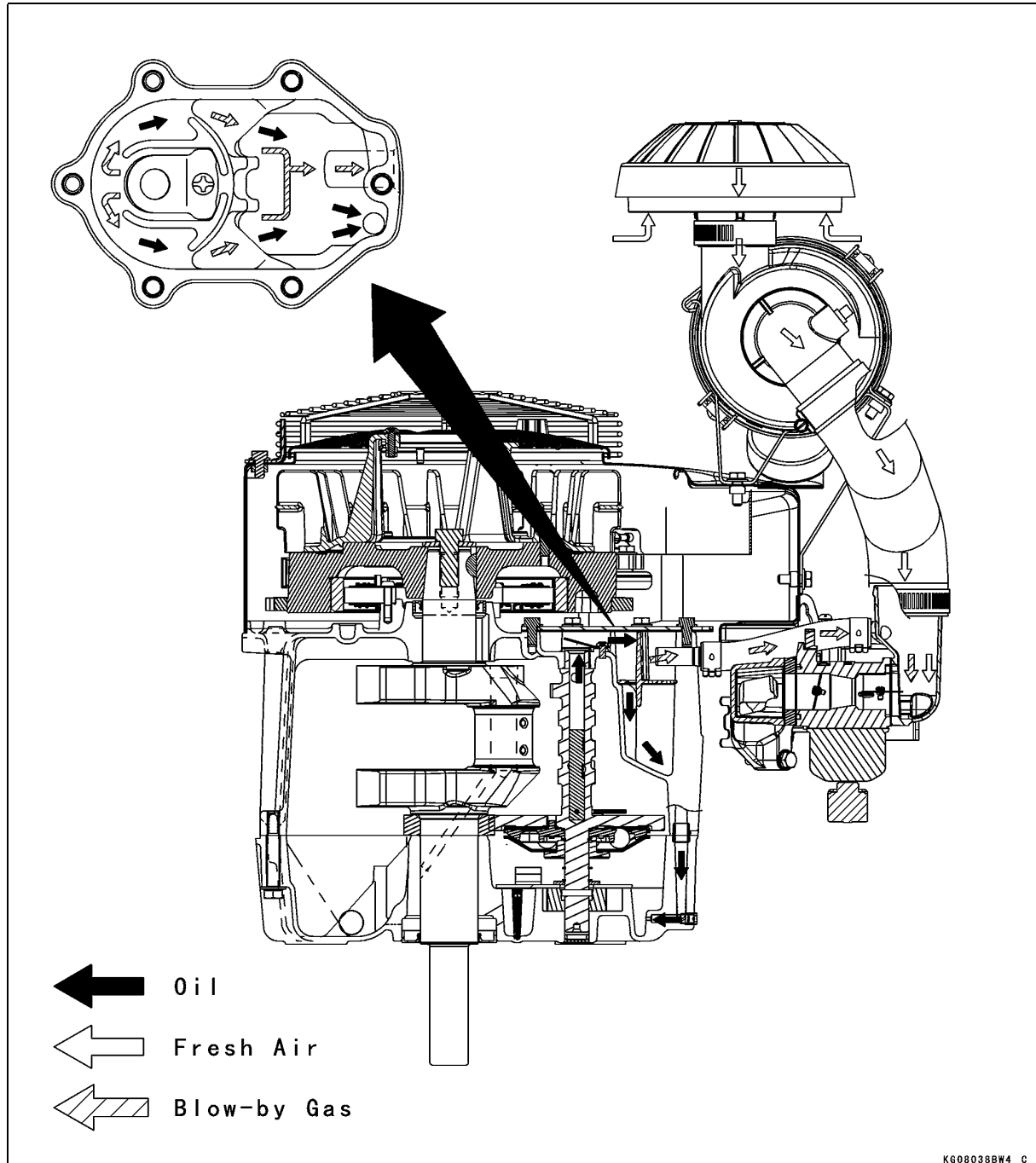

# 7-12 CAMSHAFT/CRANKSHAFT

## Breather

### Recoil Starter Model (FX Models)

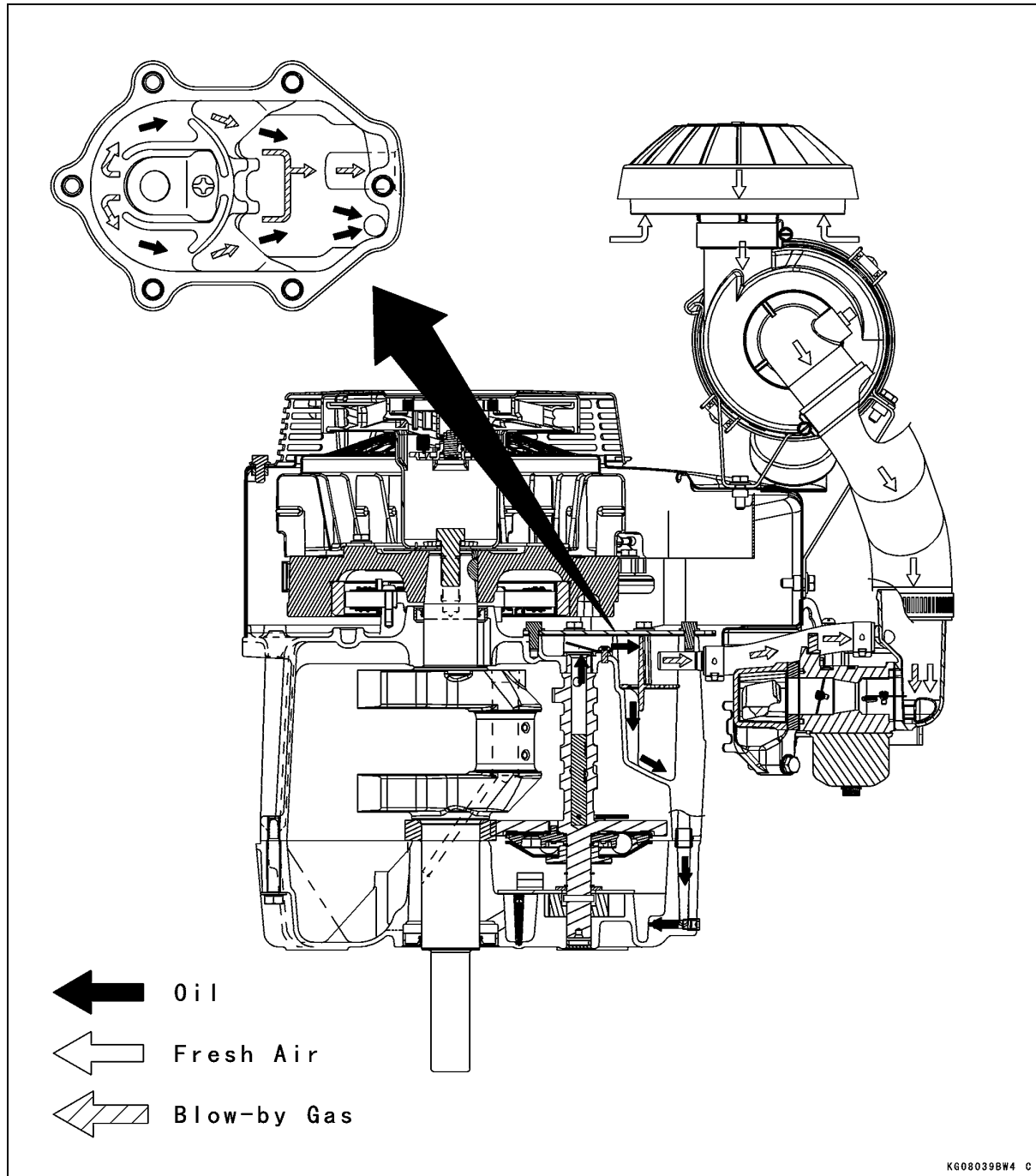

Breather

Electric Starter Model (FS and FR Models)

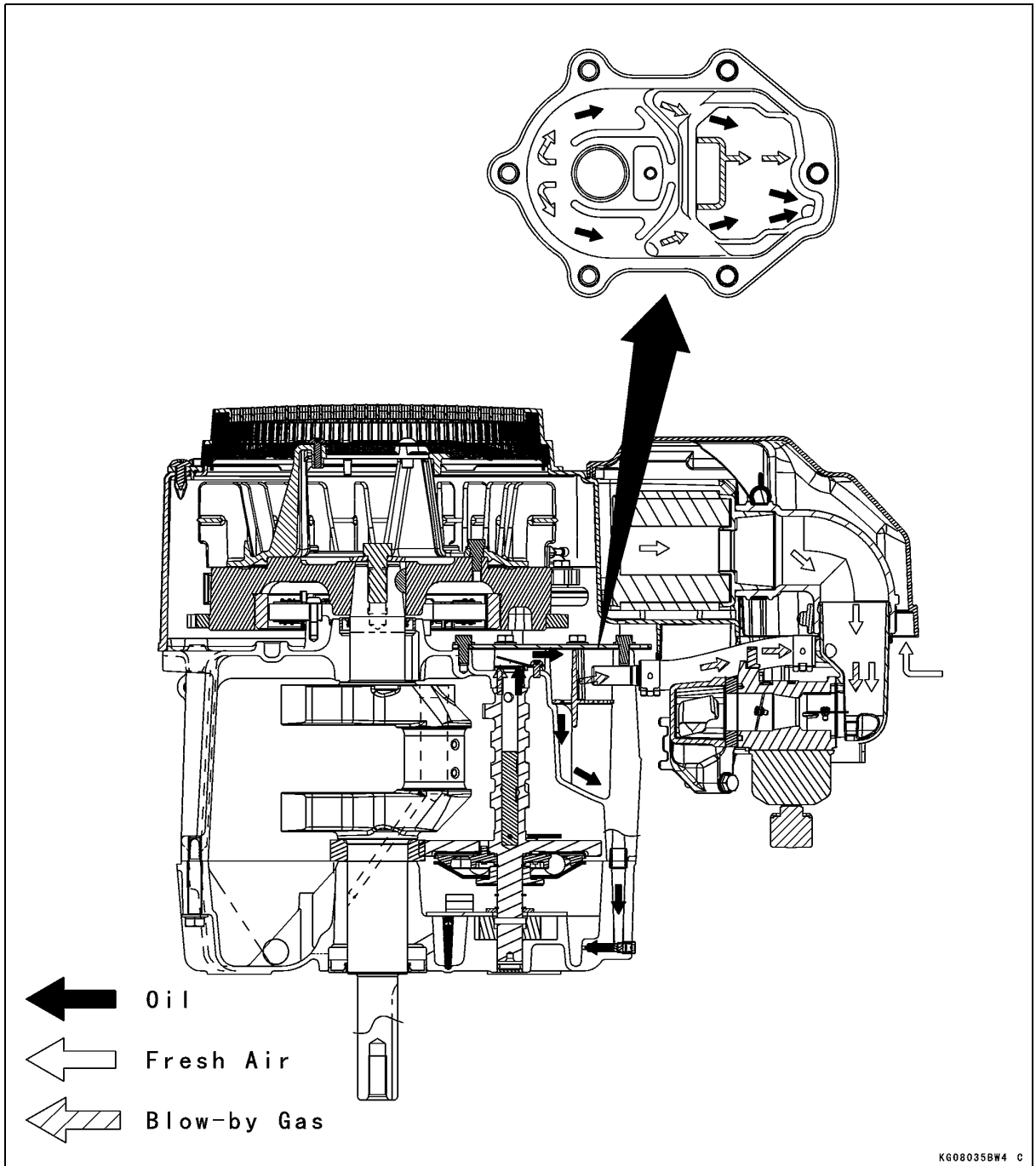

# 7-14 CAMSHAFT/CRANKSHAFT

## Breather

### Recoil Starter Model (FS Models)

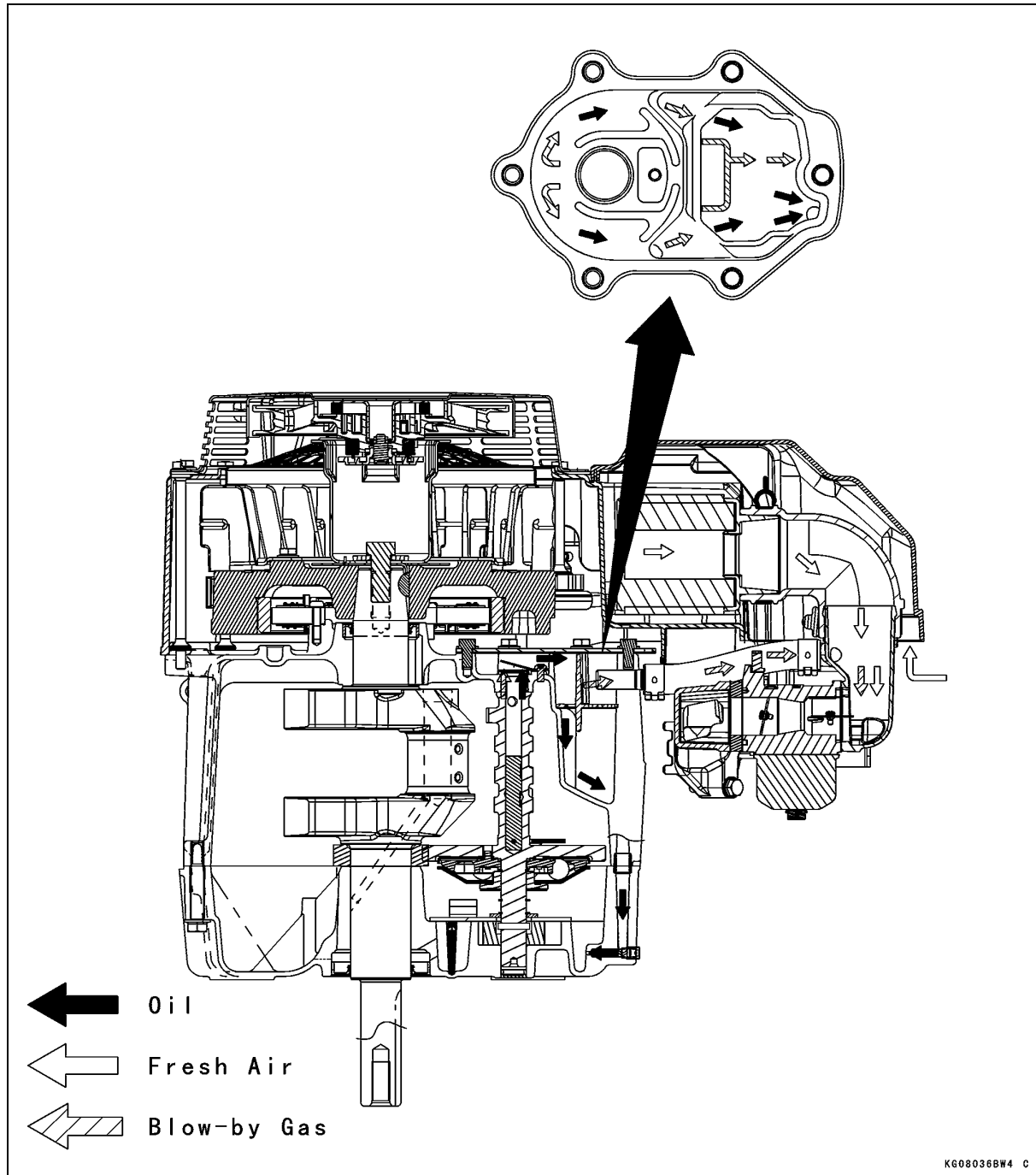

## Breather

### **Breather Valve Removal**

- Remove the stator coil (see Flywheel and Stator Coil Removal in the Electrical System chapter).
- Cut off the band [A].
- Remove:
  - Bolts [B]
  - Breather Chamber Cover [C]

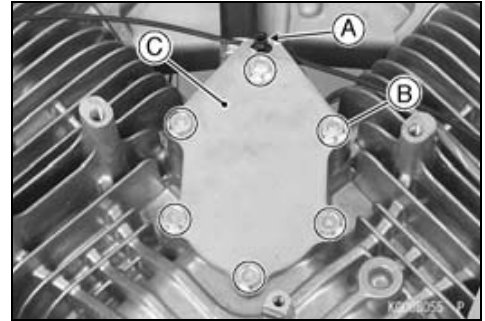

- Remove:
  - Breather Pipe [A] (see Breather Pipe Removal)
  - Breather Valve Mounting Screw [B]
  - Back Plate [C]
  - Reed Valve [D]

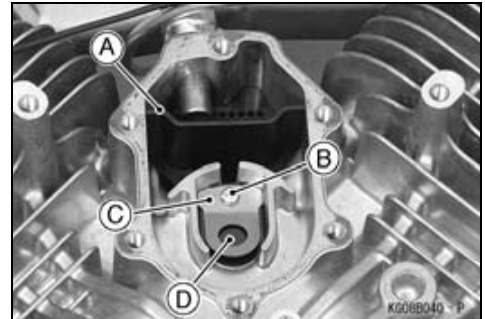

### **Breather Valve Installation**

- Align center of the valve seat with center of the reed valve and back plate.
- Tighten:
  - **Torque - Breather Valve Mounting Screw: 2.0 N·m (0.20 kgf·m, 18 in·lb)**
- Be sure the drain hole [A] on the breather chamber does not accumulate with slugs.



- Replace the breather chamber cover gasket with a new one.
- Install:
  - Breather Pipe (see Breather Pipe Installation)
  - Gasket
  - Breather Chamber Cover [A]
- Tighten:
  - **Torque - Breather Chamber Cover Bolts [B]: 5.9 N·m (0.60 kgf·m, 52 in·lb)**
- Attach the stop switch lead [C] to the breather chamber cover with the band [D].
- Install the removed parts (see appropriate chapters).

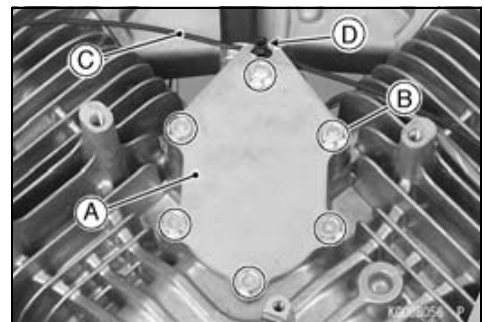

## 7-16 CAMSHAFT/CRANKSHAFT

### Breather

#### **Breather Valve Inspection**

- Inspect the reed valve [A] for breakage, crack or distortion, replace it with a new one if necessary.
- Inspect the plate [B] for damage or rough contact surface, replace it with a new one if necessary.
- Inspect the valve seating surface. The surface should be no nicks or burrs.

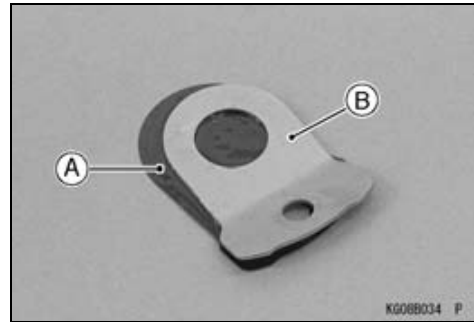

#### **Breather Pipe Removal**

- Remove:
  - Breather Chamber Cover (see Breather Valve Removal)
  - Breather Pipe [A]



#### **Breather Pipe Installation**

- Install the breather pipe [A].
- Install the removed parts (see appropriate chapters).



## Camshaft, Tappet

### Camshaft, Tappet Removal

- Set the engine on a clean surface while parts are removed.
- Drain the engine oil (see Engine Oil Change in the Periodic Maintenance chapter).
- Remove:
  - Crankcase Cover (see Crankcase Cover Removal)
  - Cylinder Head Assembly (see Cylinder Head Assembly Removal in the Engine Top End chapter)
- Turn the crankcase upside down so that the tappets will fall away from the cam lobes.
- Pull the camshaft [A] out of the crankcase.

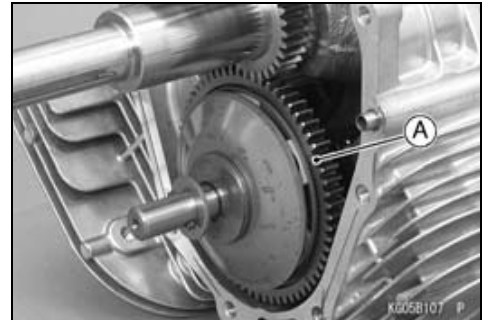

- Remove the tappets [A] and mark them so they can be installed in their original positions during assembly.

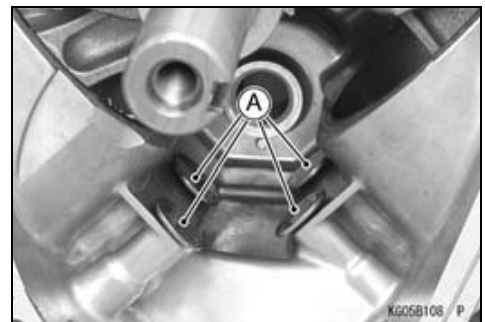

### Camshaft, Tappet Installation

- Apply engine oil to the followings.
  - Tappet Journal
  - Camshaft Journal
  - Cam Lobe Surface
  - Camshaft Gear
- Align the punch marks [A] on the crankshaft gear and camshaft gear.
- Install the removed parts (see appropriate chapters).



### Camshaft Disassembly

- Remove:
  - Governor Assembly (see Governor Assembly Removal in the Fuel System chapter)
  - Spring [A]
- Do not remove the ACR (automatic compression release) weight [B].

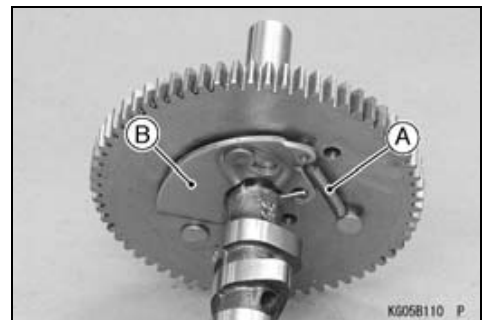

## 7-18 CAMSHAFT/CRANKSHAFT

### Camshaft, Tappet

#### Camshaft Assembly

- Install the governor assembly (see Governor Assembly Installation in the Fuel System chapter).
- After assembling the camshaft, check the following items.
  - The governor plate [A] must move freely.
  - While shaking the camshaft, check if the ACR weight [B] swings smoothly.

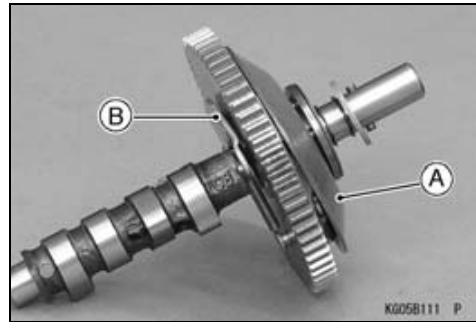

#### Camshaft Inspection

- Check the camshaft gear [A] for pitting, fatigue cracks, burrs or any evidence of improper tooth contact.
- ★ Replace the camshaft with a new one if necessary.
- Check the top of the cam lobes [B] for wear, burrs or uneven contact.
- ★ Replace the camshaft with a new one if necessary.

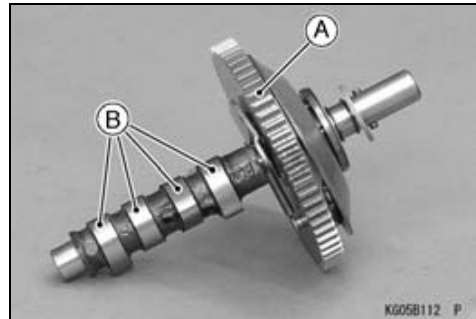

#### Camshaft Bearing/Journal Wear

- Measure the height [A] of each cam lobe.
- ★ If the cam height is less than the service limit for either lobe, replace the camshaft with a new one.

#### Cam Lobe Height

##### Service Limit:

Intake	29.62 mm (1.166 in.)
Exhaust	29.62 mm (1.166 in.)

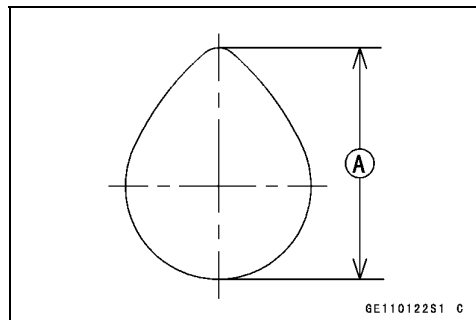

- Measure both camshaft journal diameter [A] at several points around the journal circumference.
- ★ If the journal diameter is less than the service limit, replace the camshaft with a new one.

#### Camshaft Journal Diameter

##### Service Limit:

PTO Side	15.99 mm (0.630 in.)
Flywheel Side	15.99 mm (0.630 in.)

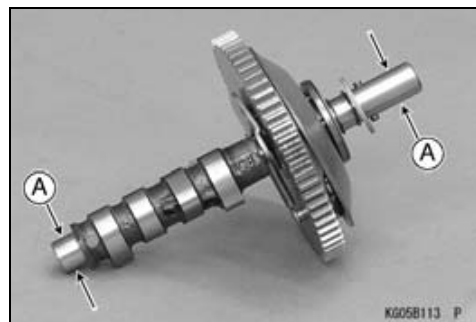

- Measure the inside diameter [A] of the camshaft insert on the crankcase at several points.
- ★ If the inside diameter is more than the service limit, replace the crankcase with a new one.

#### Camshaft Bearing Inside Diameter (Crankcase)

Service Limit: 16.14 mm (0.635 in.)



### Camshaft, Tappet

- Measure the inside diameter [A] of the camshaft insert on the crankcase cover at several points.
- ★ If the inside diameter is more than the service limit, replace the crankcase cover with a new one.

**Camshaft Bearing Inside Diameter (Crankcase Cover)**

**Service Limit: 16.14 mm (0.635 in.)**



## 7-20 CAMSHAFT/CRANKSHAFT

### Crankshaft, Connecting Rod

#### **Connecting Rod Removal**

- Remove the piston (see Piston Removal in the Engine Top End chapter).

#### **Connecting Rod Installation**

- Install the piston (see Piston Installation in the Engine Top End chapter).

#### **Crankshaft Removal**

- Remove:
  - Camshaft (see Camshaft, Tappet Removal)
  - Connecting Rod and Pistons (see Piston Removal in the Engine Top End chapter)
- Pull the crankshaft [A] out of the crankcase. Tap gently with a wooden or plastic mallet if necessary to loosen the crankshaft.

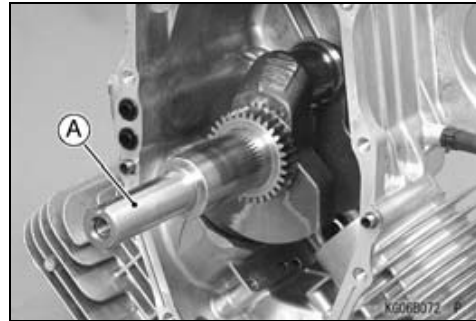

#### **Crankshaft Installation**

- Clean up the crankshaft and crankcase thoroughly, especially at the bearing contact surfaces.
- Pack some amount of high-temperature grease into the oil seals on the crankcase.
- Apply engine oil to the crankshaft journal.
- Apply molybdenum disulfide oil solution to the crankpin.
- The molybdenum disulfide oil solution is a mixture of engine oil and molybdenum disulfide grease with a weight ratio (10:1).
- Carefully insert the crankshaft end into the main bearing in the crankcase.

#### **Cleaning/Inspection**

- After removing, clean the crankshaft and the connecting rods with a high flash-point solvent and dry them with compressed air.
- Inspect the teeth of the crankshaft gear for pitting, fatigue cracks, burrs and any evidence of improper tooth contact.
- ★ Replace the crankshaft with a new one if necessary.
- Inspect the crankshaft and connecting rods especially at the bearing surfaces for wear, scratches, any evidence of improper contact or other damages.
- ★ Replace them with new ones if necessary.

## Crankshaft, Connecting Rod

### Connecting Rod Bend/Twist

- Measure the connecting rod bend.
- Select an arbor [A] of the same diameter as the connecting rod big end, and insert the arbor through the connecting rod big end.
- Select an arbor of the same diameter as the piston pin and at least 100 mm (3.94 in.) long, and insert the arbor through the connecting rod small end.
- On a surface plate, set the big-end arbor on V blocks.
- With the connecting rod held vertically, use a height gauge to measure the height difference of the small end arbor on the surface plate. Using a dial gauge, measure the height at two different positions and the distance of the two positions is 100 mm (3.94 in.) [B]. Then determine the connecting rod bent from the measured height differences [C].
- ★ If connecting rod bend exceeds the service limit, replace the connecting rod with a new one.

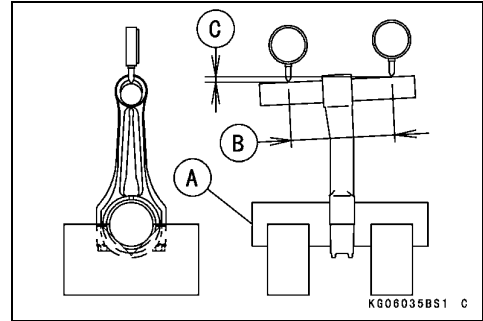

### Connecting Rod Bend

**Service Limit: TIR 0.15/100 mm (0.006/3.94 in.)**

- Measure the connecting rod twist.
- With the big-end arbor still on the V blocks, hold the connection rod horizontally and measure the amount that the small end arbor difference. Using a dial gauge, measure the height at tow different positions and the distance of the two positions is 100 mm (3.94 in.) [A]. Then determine the connecting rod twist from the measured height differences [B].
- ★ If connection rod twist exceeds the service limit, replace the connecting rod with a new one.

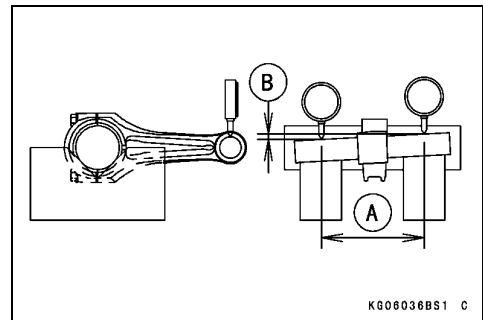

### Connecting Rod Twist

**Service Limit: TIR 0.15/100 mm (0.006/3.94 in.)**

### Connecting Rod Big End/Crankpin Width Wear

- Measure the connecting rod big end width [A] with a micrometer or a dial caliper.
- ★ If the measurement is less than the service limit, replace the connecting rod with a new one.

### Connecting Rod Big End Width

**Service Limit: 19.00 mm (0.748 in.)**



## 7-22 CAMSHAFT/CRANKSHAFT

### Crankshaft, Connecting Rod

- Measure the crankpin width [A] with a dial caliper.
- ★ If the crankpin width is more than the service limit, replace the crankshaft with a new one.

#### Crankpin Width

Service Limit: 40.0 mm (1.57 in.)

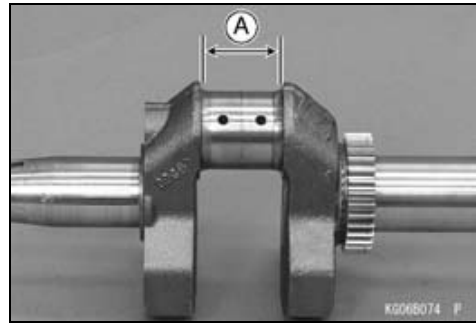

#### Connecting Rod Big End Bearing/Crankpin Wear

- Apply a light film of engine oil on the threads of the cap bolts.
- Install the cap bolts and tighten the bolts to the specified torque (see Piston Installation in the Engine Top End chapter).
- Measure the inside diameter [A] of big end at several points with a telescoping gauge or inside micrometer.
- ★ If the inside diameter is more than the service limit, replace the connecting rod with a new one.



#### Connecting Rod Big End Inside Diameter

Service Limit: 38.04 mm (1.498 in.)

- Measure the crankpin outside diameter [A].
- Use a micrometer to measure several points around the crankpin circumference.
- ★ If the crankpin diameter is less than the service limit, replace the crankshaft with a new one.

#### Crankpin Outside Diameter

Service Limit: 37.94 mm (1.494 in.)



#### Crankshaft Runout

- Measure the crankshaft runout.
- Set the crankshaft in a flywheel alignment jig [A] or on V blocks gauge.
- Set a dial gauge [B] against both bearing journals.
- Turn the crankshaft slowly to measure the runout. The difference between the highest and lowest dial gauge readings (TIR) is the amount of runout.
- ★ If the measurement exceeds the service limit, replace the crankshaft with a new one.

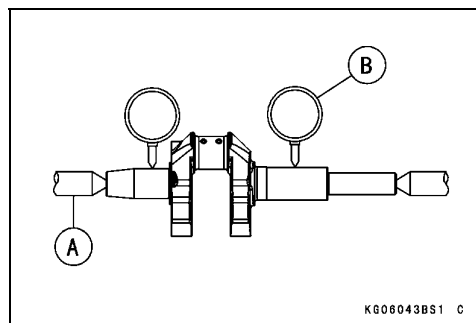

#### Crankshaft Runout

Service Limit: TIR 0.05 mm (0.002 in.)

---

**Crankshaft, Connecting Rod**

---

***Crankshaft Main Journal/Wear***

- Measure both main journals at several points around the journal circumference.
- ★ If the journal diameter is less than the service limit, replace the crankshaft with a new one.

**Crankshaft Journal Diameter****Service Limit:**

PTO Side [A]      37.90 mm (1.492 in.)

Flywheel Side [B]    34.90 mm (1.374 in.)

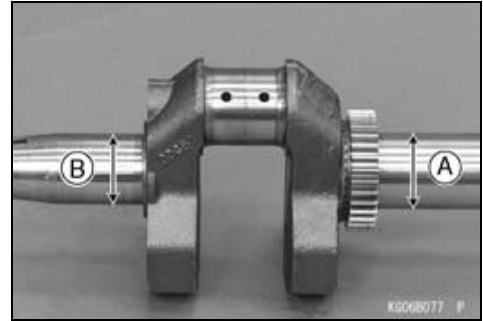



# Starter System

## Table of Contents

Exploded View.....	8-2
Specifications .....	8-8
Electric Starter System.....	8-9
Starter Motor Removal.....	8-9
Starter Motor Installation.....	8-9
Starter Solenoid and Circuit Test .....	8-9
Starter Motor Test .....	8-10
Starter Motor Disassembly.....	8-11
Starter Motor Assembly .....	8-14
Starter Motor Brush Inspection .....	8-19
Brush Spring Inspection.....	8-19
Armature Inspection.....	8-20
Yoke Assembly Inspection .....	8-23
Pinion Clutch Inspection .....	8-24
Recoil Starter Removal.....	8-25
Recoil Starter Installation.....	8-25
Recoil Starter Disassembly.....	8-25
Recoil Starter Assembly.....	8-26

# 8-2 STARTER SYSTEM

## Exploded View

FS and FX, FR541/600V-DS00 Model

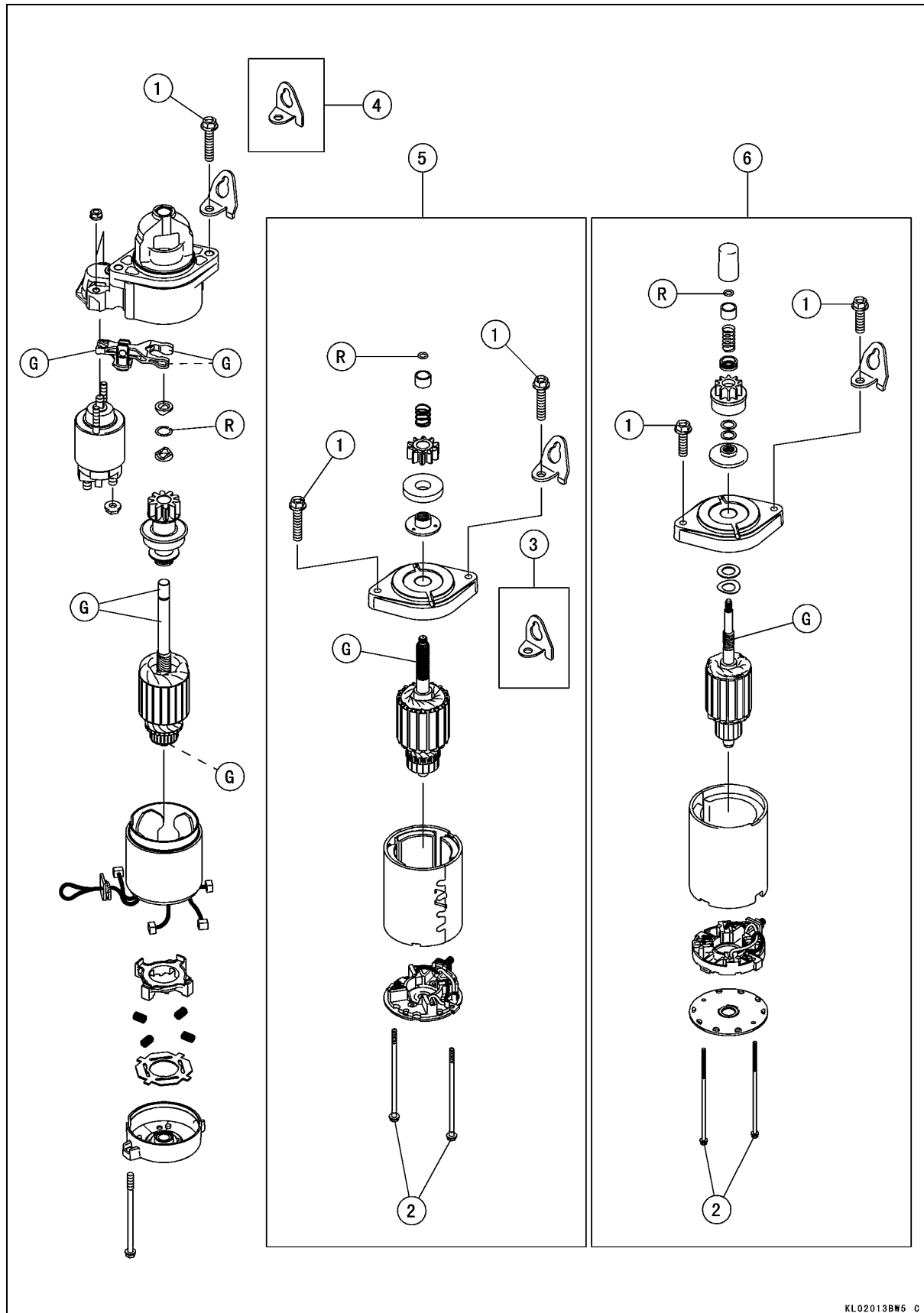

**Exploded View**

No.	Fastener	Torque			Remarks
		N·m	kgf·m	ft·lb	
1	Starter Motor Mounting Bolts	19.6	2.0	14	
2	Starter Motor Through Bolts	3.95	0.40	35 in·lb	

3. FS481/541/600V-AS00 Models

4. FX481/541/600V-AS00 Models

5. FS481/541/600V-AS00 ~ DS00 Models

6. FS481/541/600V-ES00 and FR541/600V-ES00 Models

G: Apply grease.

R: Replacement Parts

# 8-4 STARTER SYSTEM

## Exploded View

FR541/600V-AS00 ~ CS00 Models

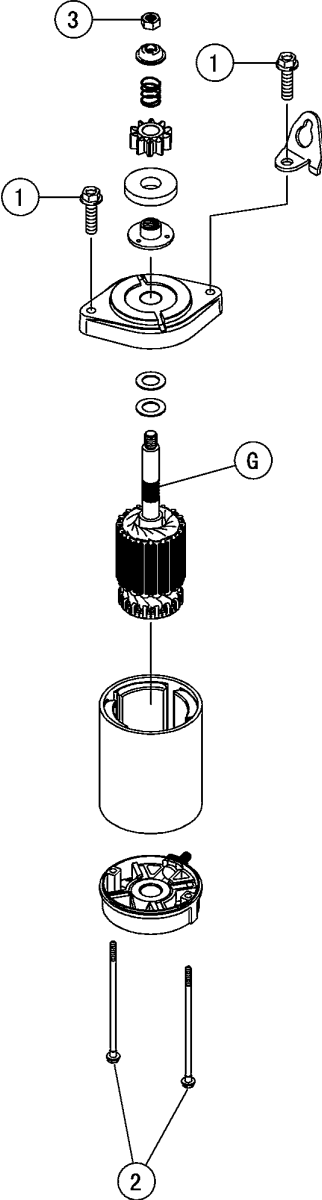

## STARTER SYSTEM 8-5

### Exploded View

No.	Fastener	Torque			Remarks
		N·m	kgf·m	ft·lb	
1	Starter Motor Mounting Bolts	19.6	2.0	14	
2	Starter Motor Through Bolts	5.88	0.60	52 in·lb	
3	Armature Shaft Nut	10.3	1.05	91 in·lb	

G: Apply grease.

R: Replacement Parts

# 8-6 STARTER SYSTEM

## Exploded View

### Recoil Starter Model

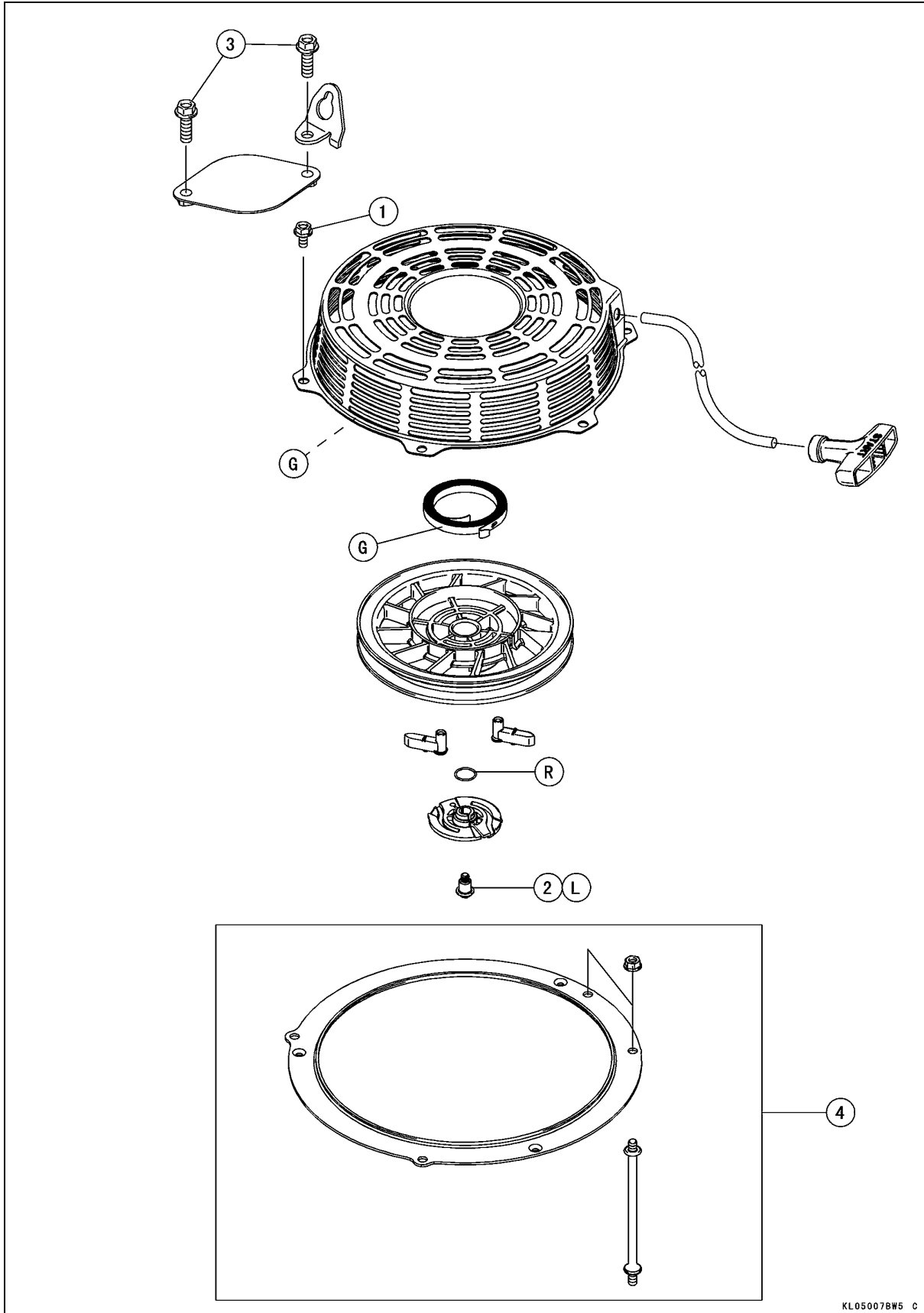

## STARTER SYSTEM 8-7

### Exploded View

No.	Fastener	Torque			Remarks
		N·m	kgf·m	ft·lb	
1	Recoil Starter Mounting Bolts	5.9	0.60	52 in·lb	
2	Recoil Starter Retainer Screw	5.9	0.60	52 in·lb	L
3	Starter Motor Plate Mounting Bolts	19.6	2.0	14	

4. FS Models

G: Apply grease.

R: Replacement Parts

## 8-8 STARTER SYSTEM

### Specifications

Item	Standard	Service Limit
<b>Electric Starter System</b>		
Starter Motor:		
Carbon Brush Length:		
FX Models	10.0 mm (0.39 in.)	6.0 mm (0.24 in.)
FS Models	---	10.16 mm (0.4 in.)
FR Models	12.8 mm (0.50 in.)	6.4 mm (0.25 in.)
Commutator Groove Depth:		
FX Models	0.6 mm (0.02 in.)	0.2 mm (0.008 in.)
FS Models	---	1.27 mm (0.05 in.)
Commutator Diameter:		
FX Models	28.0 mm (1.10 in.)	27.0 mm (1.06 in.)
FS Models	---	31.369 mm (1.235 in.)
Commutator Runout:		
FX Models	---	0.4 mm (0.016 in.)
FS Models	---	0.043 mm (0.0017 in.)

## Electric Starter System

### Starter Motor Removal

- Disconnect the wire.
- Remove the mounting bolts [A] and pull the starter motor [B] from the engine with the switch lead attached.

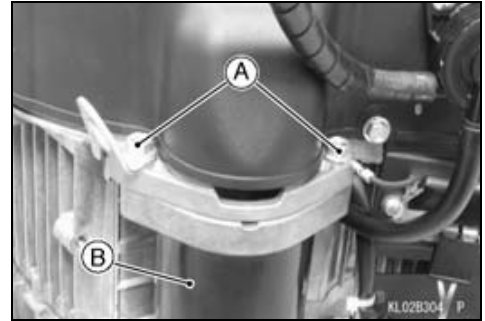

### Starter Motor Installation

- Clean the starter motor and engine mounting flanges to ensure good electrical contact and tighten the mounting bolts.
- Install the hook [A] so that the stopper [B] of the hook contacts the crankcase.

**Torque - Starter Motor Mounting Bolts: 19.6 N·m (2.00 kgf·m, 14.4 ft·lb)**

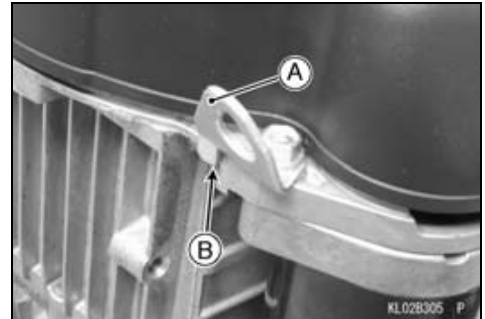

### Starter Solenoid and Circuit Test

#### NOTE

- Before this test, be sure the battery is fully charged.
- Disconnect the starter motor lead [A] from the solenoid terminal as shown and keep the lead away from the solenoid terminal.
- Measure the continuity of the solenoid when activated.
- Set the hand tester selector switch to the  $R \times 1 \Omega$  position and connect the leads across the large terminals [A] as shown in the figure.
- Turn the engine switch to the START position and read the tester.
- ★ If the solenoid does not click or if the tester reads more than  $0 \Omega$  the solenoid is faulty. Replace it.
- ★ If the solenoid makes a single clicking sound, the tester reads  $0 \Omega$  and the rest of the starter circuit is good.
- ★ If solenoid clicks once but the tester does not read  $0 \Omega$ , the solenoid is faulty. Replace it.
- ★ If the solenoid does not click at all, proceed with the following.



## 8-10 STARTER SYSTEM

### Electric Starter System

- Disconnect the switch lead [A].

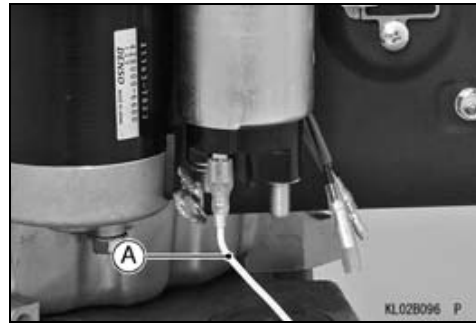

- Set the hand tester to the  $R \times 1 \Omega$  position and connect the leads as shown in the figure.

Switch Terminal [A]  
To Ground [B]

- ★ If the tester does not read close to  $0 \Omega$ , the solenoid is faulty. Replace it.
- ★ If the tester reads close to  $0 \Omega$ , the solenoid may be good.

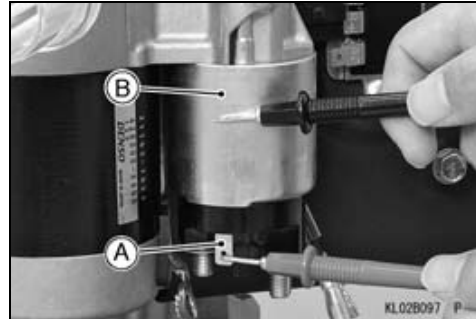

- Check the voltage to the solenoid from the engine switch.
- Set the hand tester selector switch to the 25 V DC position and connect it as shown in the figure.

Switch Lead Connector [A]  
To Ground [B]

- Turn the engine switch to the START position and read the tester.
- ★ If the tester reads battery voltage, the circuit is good.
- ★ If the tester reads much less than battery voltage or no voltage at all, either the wiring or the engine switch is bad. Check the engine switch or the wiring for damaged or broken wires and replace as required.



### Starter Motor Test

#### NOTE

○ Always inspect the Starter Solenoid and Circuit Test section before starting following procedures.

- Remove the starter motor (see Starter Motor Removal).
- Hold the starter motor with a vice.

#### NOTICE

**Be careful not to deform the starter motor body when holding it with a vice.**

- Connect the first jumper cable to the battery (+) terminal and the large terminal on the solenoid as shown in the figure.
- Connect a suitable switch between the battery (+) terminal and the switch terminal on the solenoid as shown in the figure.
- Connect the second jumper cable to the battery (-) terminal and the starter motor body.
- Turn on the switch intermittently for one second intervals.
- The pinion should rotate freely.
- ★ If the pinion does not rotate freely, replace the starter motor.

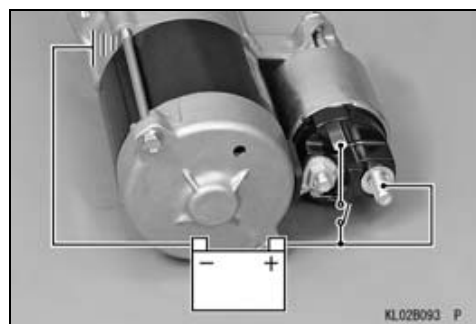

## Electric Starter System

### Starter Motor Disassembly

#### FX Models

- Loosen the terminal nut [A].
- Remove the lead [B] from the starter motor to the solenoid.

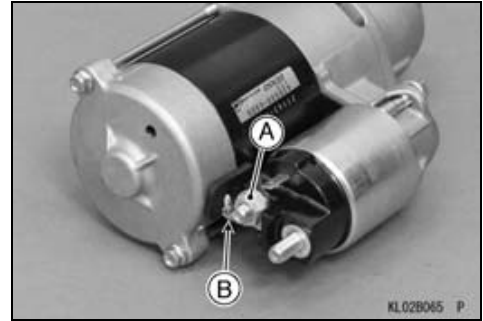

- Unscrew the mounting nuts [A] and remove the solenoid assembly [B].

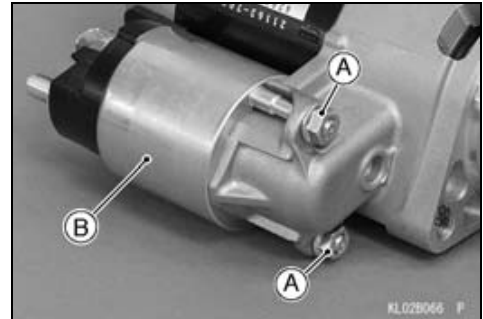

- Remove the through bolts [A] and end cover [B].
- Slide the (-) lead grommet [C] to outside.

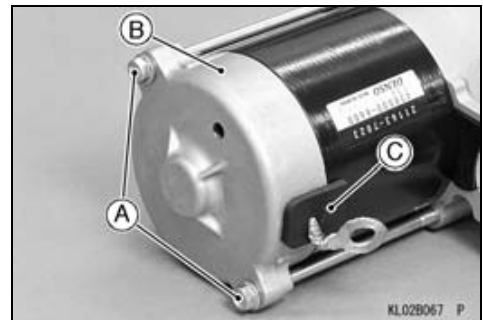

- Remove the insulator [A].

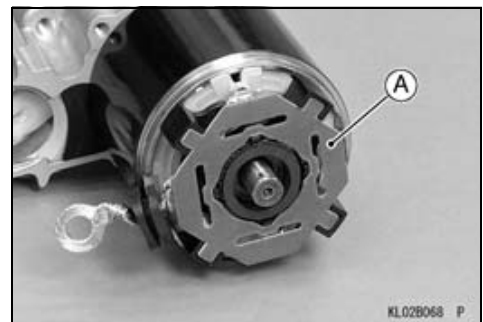

- Remove the springs [A].
- Free the brushes [B] from the brush holder [C].

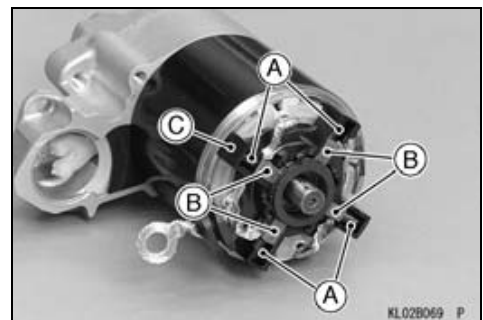

## 8-12 STARTER SYSTEM

### Electric Starter System

- Remove:  
Brush Holder [A]  
Yoke [B]

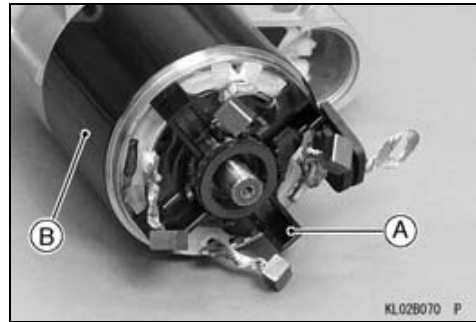

- Remove the armature assembly [A] with the pinion gear fork [B].

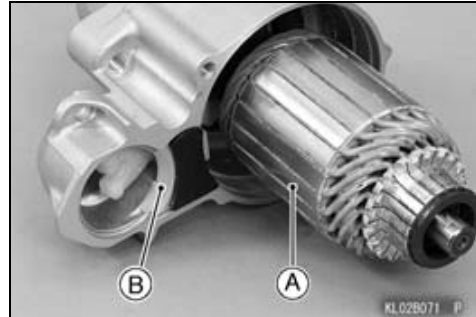

- Remove the front stopper [A].
- Push the rear stopper [B] downward and remove the snap ring [C].
- Pull the rear stopper and pinion clutch [D] from the armature shaft.

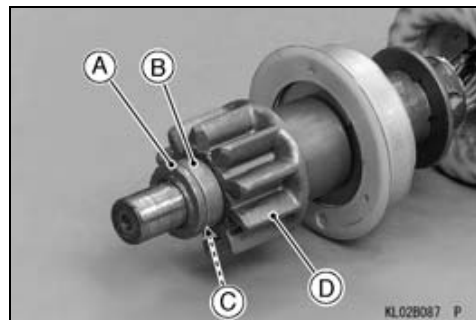

### FS Models

- Remove:  
Through Bolts [A]  
Brush Plate Assembly [B]

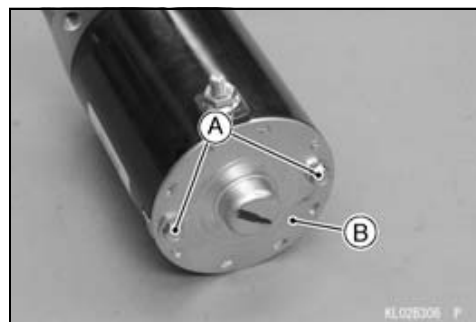

### FS481/541/600V-AS00 ~ DS00 Models

- Press the retainer [A] using a suitable tool.

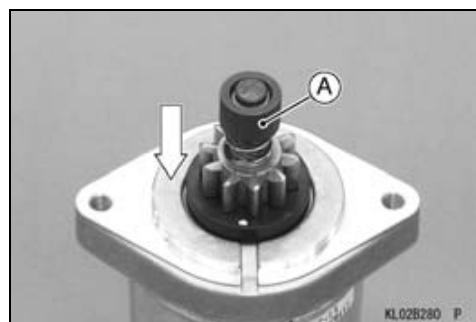

**Electric Starter System**

- Remove:
  - Snap Ring [A]
  - Retainer [B]
  - Spring [C]
  - Pinion Gear [D]
  - Rubber Damper [E]

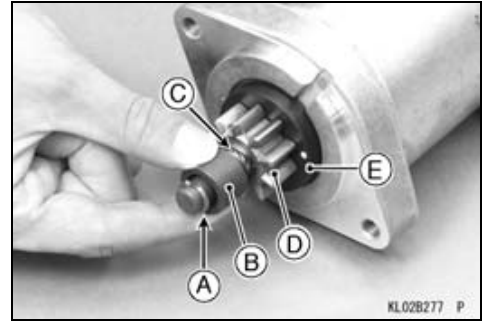

- Clockwise to remove the color [A].
- Remove the end cover [B].
- Remove the armature from the yoke.

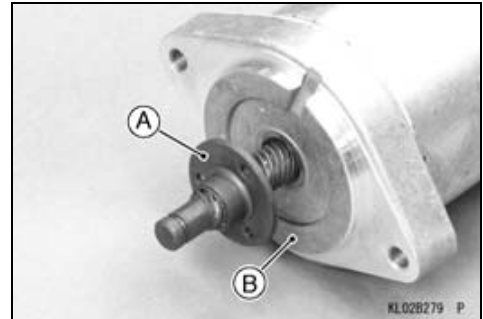

**FS481/541/600V-ES00 and FR541/600V-DS00 Models**

- Remove the cap.
- Press the retainer [A] using a suitable tool.
- Remove:
  - Snap Ring [B]
  - Retainer
  - Spring [C]
  - Spacer [D]
  - Pinion Gear [E]

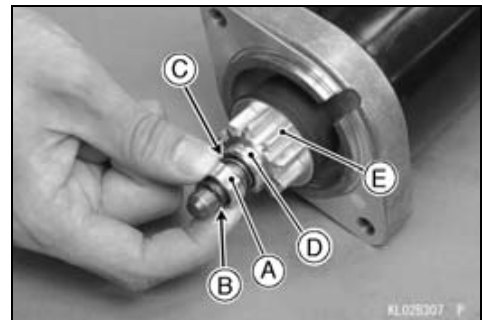

- Remove the Spacers [A].
- Clockwise to remove the color [B].
- Remove the end cover [C].
- Remove the armature from the yoke.

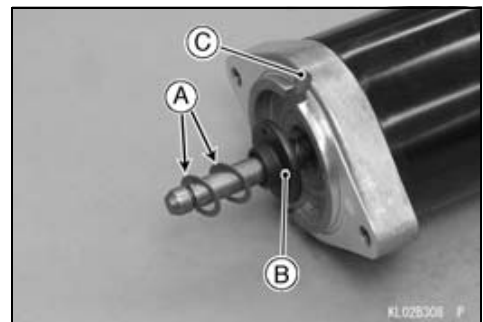

**FR541/600V-AS00 ~ CS00 Models**

- Remove:
  - Through Bolts [A]
  - Brush Plate Assembly [B]

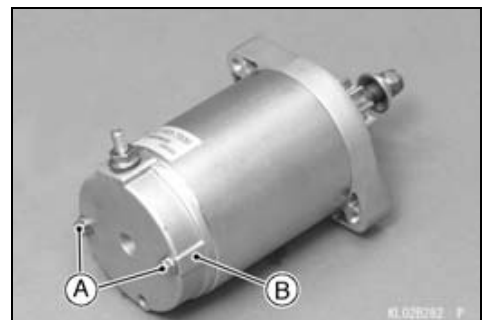

## 8-14 STARTER SYSTEM

### Electric Starter System

- Remove the yoke [A].

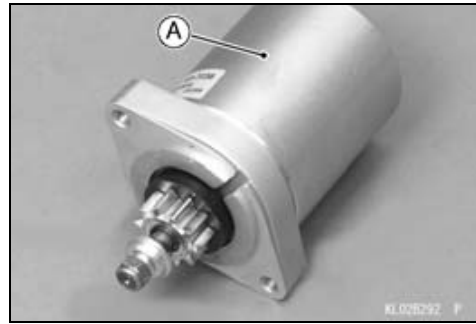

- While holding the armature [A], remove the armature shaft nut [B].

#### NOTE

○ Do not hold the armature in a vise. The armature may be damaged.

- Remove:
  - Stop Plug [C]
  - Spring [D]
  - Pinion Gear [E]
  - Rubber Plate [F]
  - Spiral [G]
  - End Cover [H]

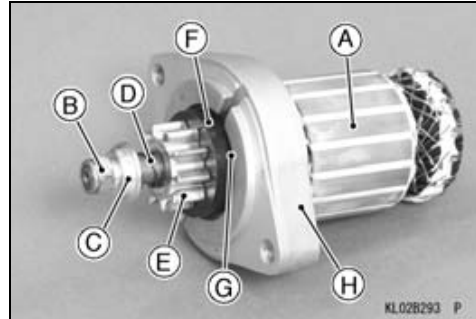

- Remove the spacers [A].

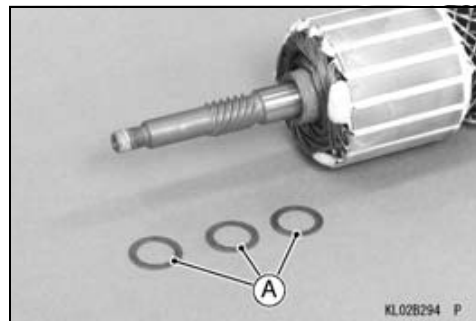

### Starter Motor Assembly

#### FX Models

- Apply a small amount of grease to the armature shaft [A] as shown in the figure.
- Do not reuse the snap ring [B]. Replace it with a new one.

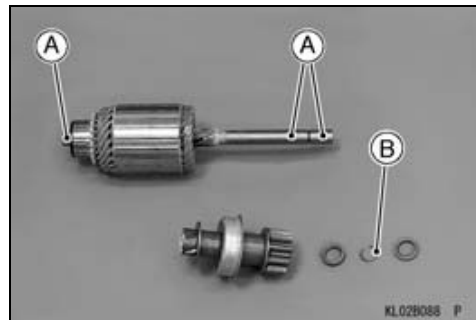

## Electric Starter System

- Inspect the boots [A], grommet [B] and rubber insert [C] for visible damage.
- ★ If it is damaged, replace the related parts.

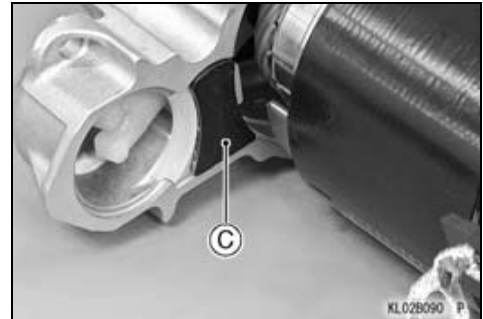
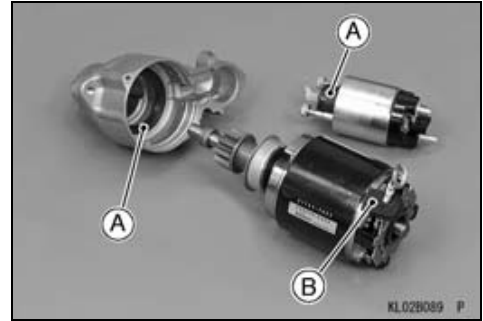

- Install the pinion clutch [A].
- Install the rear stopper [B] so that the hollow side face the outside.
- Install the snap ring [C] to the groove of the shaft.
- Slide the rear stopper until the stopping with the snap ring.
- Install the front stopper [D] so that the smaller diameter face the inside.
- Apply grease to the pinion gear fork fingers.
- Assemble the pinion gear fork [E] as shown in the figure.

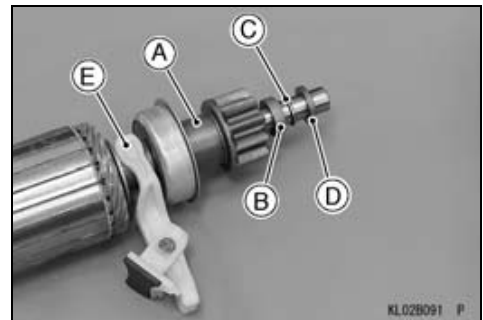

- Install the armature assembly [A] to the pinion gear cover [B].

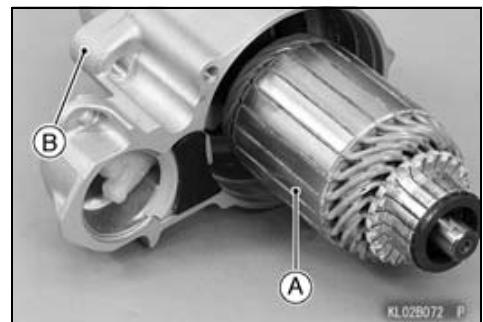

- Install the yoke so that the slit [A] fit the projection [B] of the pinion gear fork.

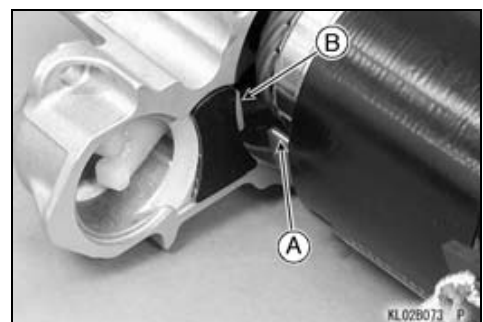

## 8-16 STARTER SYSTEM

### Electric Starter System

- Install the brush holder [A].
- Install the brushes [B] to the brush holder.

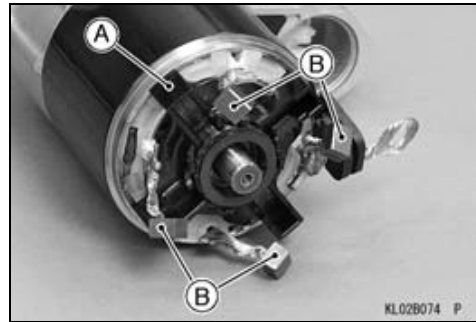

- Install the springs [A].

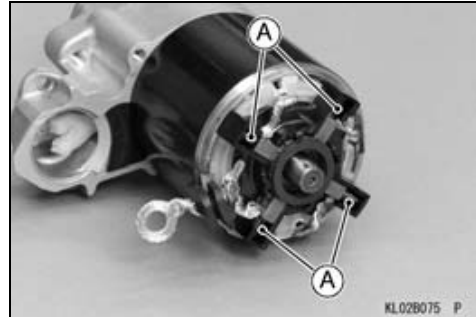

- Install the insulator [A].

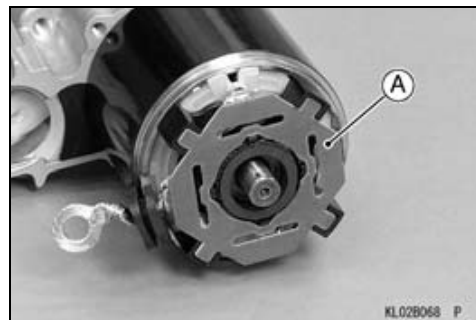

- Install the end cover so that the slit [A] fit the groove [B] of the grommet.
- Tighten the through bolts.

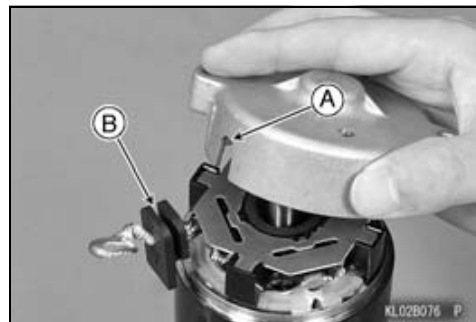

- Engage the hook on the starter solenoid with the hook [A] on the pinion gear fork [B].
- Tighten the solenoid mounting nut.

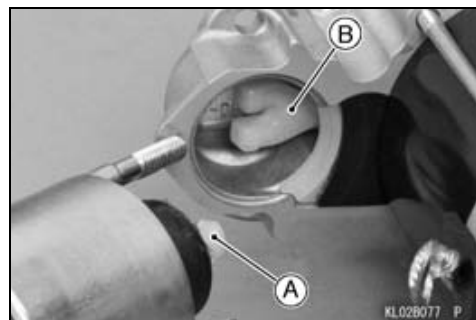

#### FS Models

- Using the suitable tool, hold the brushes.
- Install the armature assembly to the brush plate assembly.

## Electric Starter System

- Install the yoke so that the slit [A] fit the groove [B] of the brush plate assembly.

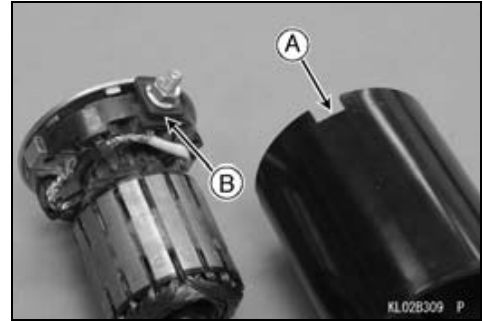

### FS481/541/600V-AS00 ~ DS00 Models

- Apply grease to the armature shaft.
- Install the end cover so that the slit [A] fit the projection [B] of the yoke.
- Tighten:  
**Torque - Starter Motor Through Bolts: 3.95 N·m (0.40 kgf·m, 35 in·lb)**

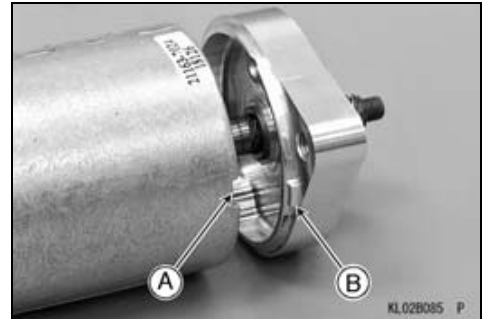

- Do not reuse the snap ring [A]. Replace it with a new one.
- Install:  
 Collar [B]  
 Rubber Damper [C]  
 Pinion Gear [D]  
 Spring [E]  
 Washer [F]  
 Snap Ring
- Make sure that grease does not attach to the contact portion between the collar and the rubber damper.
- Push up the retainer using the suitable tool, hold on the snap ring.

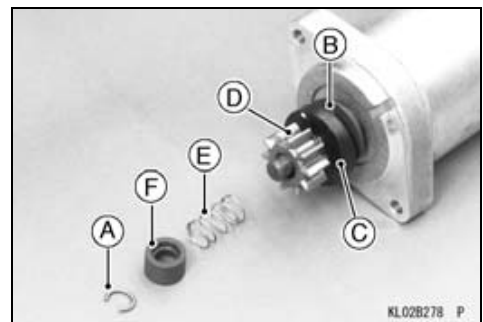

### FS481/541/600V-ES00 and FR541/600V-DS00 Models

- Apply grease to the armature shaft.
- Install the washers [A].
- Install the end cover [B] so that the slit fit the projection of the yoke.
- Tighten:  
**Torque - Starter Motor Through Bolts: 3.95 N·m (0.40 kgf·m, 35 in·lb)**

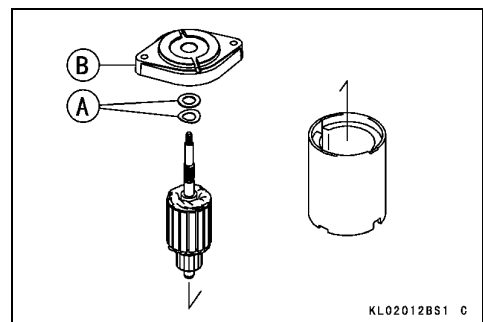

## 8-18 STARTER SYSTEM

### Electric Starter System

- Do not reuse the snap ring [A]. Replace it with a new one.
- Install:
  - Collar [B]
  - Spacer [C]
  - Pinion Gear [D]
  - Spacer [E]
  - Spring [F]
  - Washer [G]
  - Snap Ring
- Make sure that grease does not attach to the contact portion between the collar and the rubber damper.
- Push up the retainer using the suitable tool, hold on the snap ring.
- Install the cap [H].

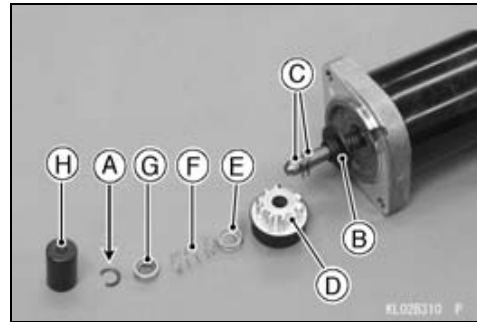

#### FR541/600V-AS00 ~ CS00 Models

- Apply grease to the armature shaft.
- Install the spacers [A].

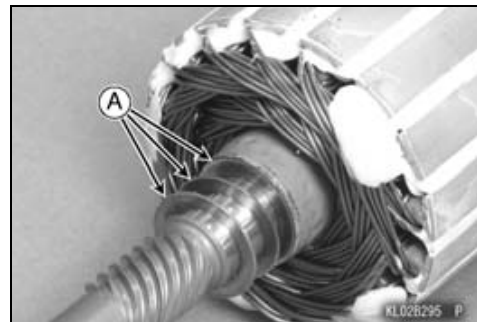

- Install:
  - End Cover [A]
  - Spiral [B]
  - Rubber Plate [C]
  - Pinion Gear [D]
  - Spring [E]
  - Stop Plug [F]
- Make sure that grease does not attach to the contact portion between the spiral and the rubber plate.
- Tighten:
  - Torque - Armature Shaft Nut [G]: 10.3 N·m (1.05 kgf·m, 91 in·lb)**

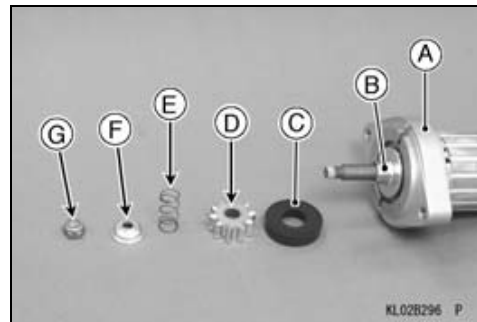

- Install the end cover so that the slit [A] fit the projection [B] of the yoke.

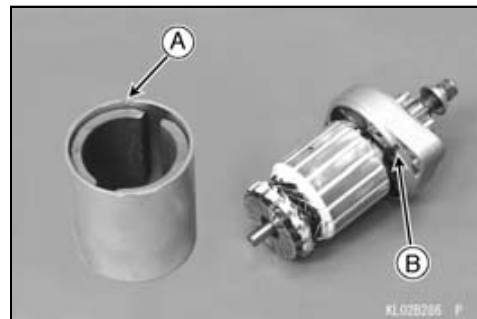

## Electric Starter System

- Using the suitable tool, hold the brushes.
- Install the brush plate assembly so that the slit [A] fit the projection [B] of the yoke.
- Tighten:  
**Torque - Start Motor Through Bolts: 5.88 N·m (0.60 kgf·m, 52 in·lb)**

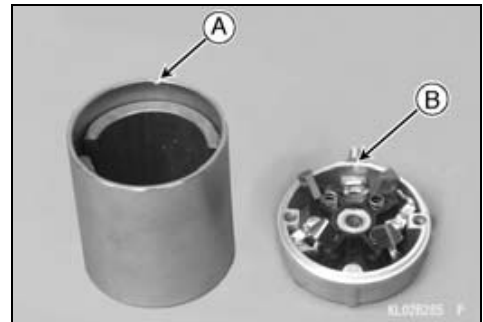

### Starter Motor Brush Inspection

- Measure the overall length [A] of each brush.
  - ★ If the brushes are shorter than the service limit, replace them.
- FX Models [B]  
 FS Models [C]  
 FR Models [D]

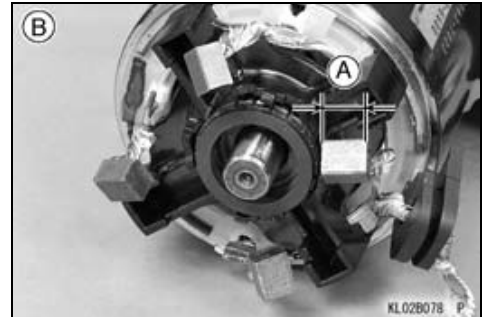

#### Brush Length

##### Standard:

FX Models	10.0 mm (0.39 in.)
FS Models	---
FR Models	12.8 mm (0.50 in.)

##### Service Limit:

FX Models	6.0 mm (0.24 in.)
FS Models	10.16 mm (0.4 in.)
FR Models	6.4 mm (0.25 in.)

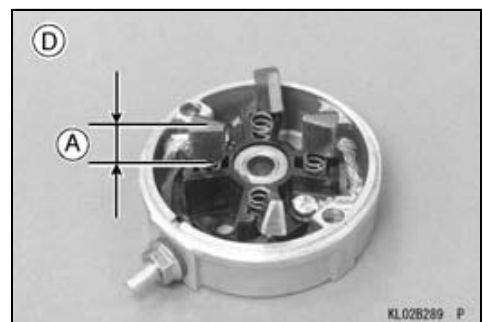

### Brush Spring Inspection

- Inspection the brush springs for pitting, cracks, rusting and burrs. Replace the spring if necessary.
- Inspect the springs for weakened conditions and distortion. Replace the spring if necessary.
- ★ If the brush springs are able to press the brushes firmly into place, they may be considered serviceable. If they cannot, replace them.

## 8-20 STARTER SYSTEM

### Electric Starter System

#### Armature Inspection

- Inspect the surface of the commutator [A].
- ★ If it is scratched or dirty, polish it with a piece of very fine emery cloth [B], and clean out the grooves.  
FS and FX Models [C]  
FR Models [D]

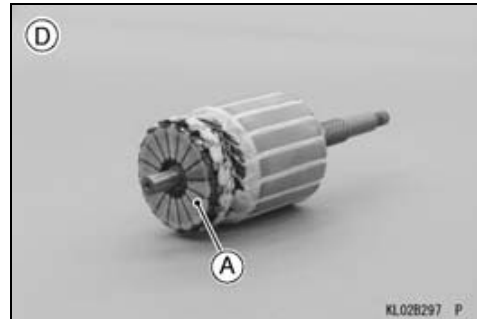
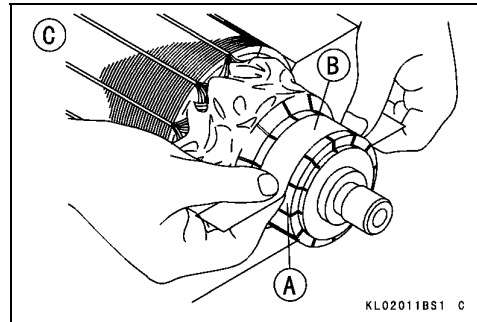

#### FS and FX Models

- Measure the depth of the grooves between the commutator segments.
- ★ If the grooves are shallower than the specified limit, replace the armature with a new one.
- ★ If the grooves are only dirty, clean them carefully.

#### Commutator Groove Depth

##### Standard:

FX Models 0.6 mm (0.02 in.)

FS Models - - -

##### Service Limit:

FX Models 0.2 mm (0.008 in.)

FS Models 1.27 mm (0.05 in.)

Bad [A]

Segment [B]

Good [C]

0.2 mm (0.008 in.) (FX Models)/1.27 mm (0.05 in.) (FS Models) limit [D]

Mica [E]

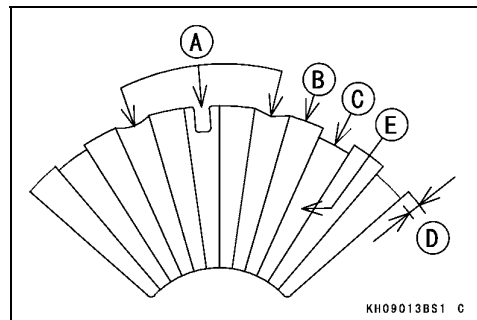

#### FR Models

- Check the commutator for damage or abnormal wear.
- ★ Replace the starter motor with a new one if there is any damage or wear.
- Visually inspect the commutator segments for discoloration.
- ★ Replace the starter motor with a new one if discoloration is noticed.

**Electric Starter System**

**FS and FX Models**

- Measure the outside diameter [A] of the commutator [B] at several points.
- ★ If the diameter is less than the service limit, replace the armature with a new one.

**Commutator Outside Diameter**

**Standard:**

**FX Models**                    **28.0 mm (1.10 in.)**

**FS Models**                    **---**

**Service Limit:**

**FX Models**                    **27.0 mm (1.06 in.)**

**FS Models**                    **31.369 mm (1.235 in.)**

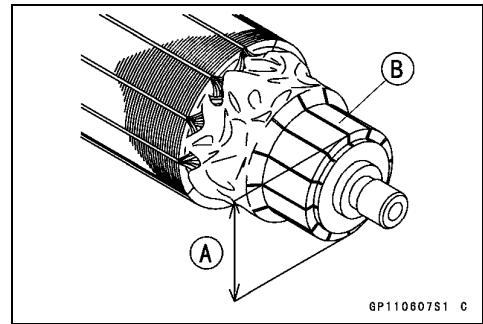

**FS and FX Models**

- Support the armature in an alignment jig at each end of the shaft as shown. Position a dial indicator perpendicular to the commutator.
- Rotate the armature slowly and read the commutator runout.
- ★ If runout is more than the service limit, replace the armature with a new one.

**Commutator Runout**

**Service Limit:**

**FX Models**                    **0.4 mm (0.016 in.)**

**FS Models**                    **0.043 mm (0.0017 in.)**

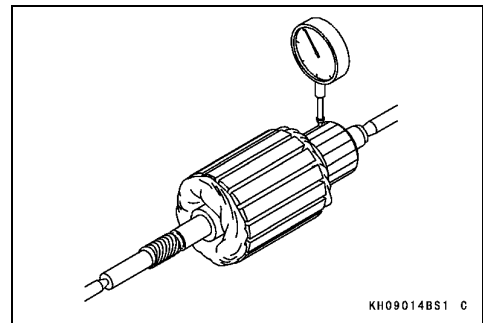

**FR Models**

- Visually inspect the commutator runout.
- ★ Replace the starter motor with a new one if runout is greater.

- Measure the armature winding resistance.
- Set the multimeter selector switch to the  $R \times 1 \Omega$  position and check the resistance between each segment and all the others.

- ★ If the resistance is too high or even infinite, the armature winding has an open circuit. Replace the starter motor.

FS and FX Models [A]

FR Models [B]

**Armature Winding Resistance**

Close ~ 0  $\Omega$

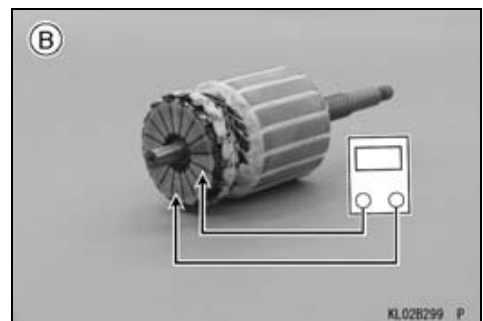
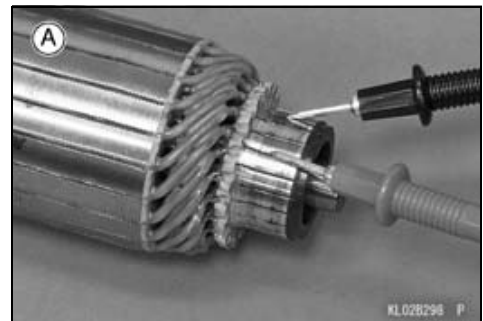

## 8-22 STARTER SYSTEM

### Electric Starter System

- Set the multimeter selector switch to the  $R \times 1 \text{ k}\Omega$  position and measure the resistance between the commutator and the armature shaft.

★ If the resistance is less than infinite, the armature is shorted.

FS and FX Models [A]

FR Models [B]

#### Commutator to Shaft Resistance

( $\infty$ )

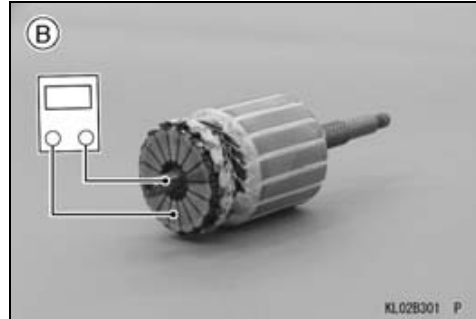
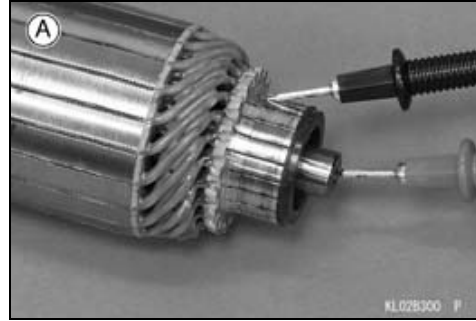

- Test the armature winding for shorts.
  - Place the armature on a growler [A].
  - Hold a thin metal strip (e.g., hack saw blade) on top of the armature.
  - Turn on the growler and rotate the armature one complete turn.
- ★ If the metal strip vibrates, the windings are internally shorted to each other and the starter motor must be replaced.

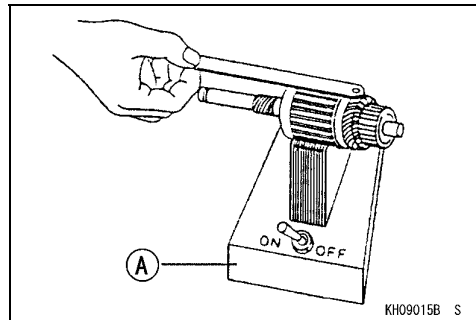

## Electric Starter System

### Yoke Assembly Inspection

- Set the multimeter selector switch to the  $R \times 1 \text{ k}\Omega$  position and measure the resistance between the positive brushes and stator motor yoke.

★ If the resistance is less than infinite, the positive brush is shorted to ground. Replace the yoke assembly.

FX Models [A]

FS Models [B]

FR Models [C]

### Positive Brush to Ground Resistance

( $\infty$ )

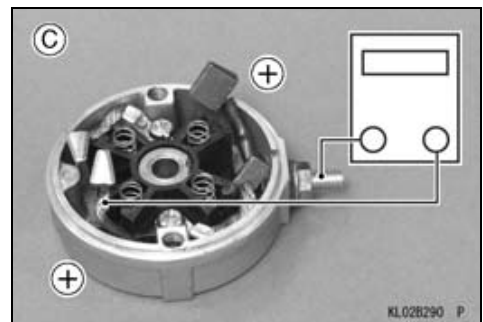
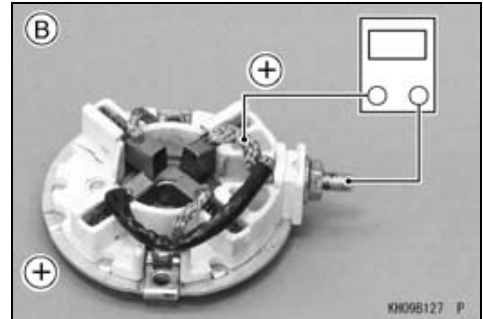
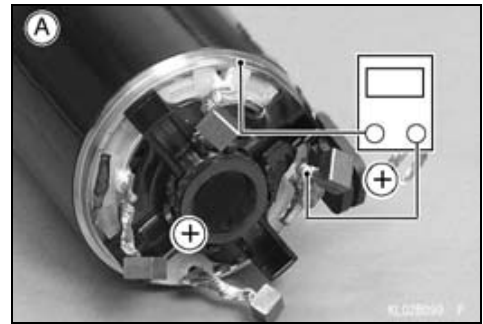

## 8-24 STARTER SYSTEM

### Electric Starter System

- Set the multimeter selector switch to the  $R \times 1 \Omega$  position and measure the resistance between the negative brushes and starter motor yoke.

★ If the meter does not read close  $\sim 0 \Omega$ , the yoke assembly is faulty. Replace it.

FX Models [A]

FS Models [B]

FR Models [C]

#### Negative Brush to Ground Resistance

Close  $\sim 0 \Omega$

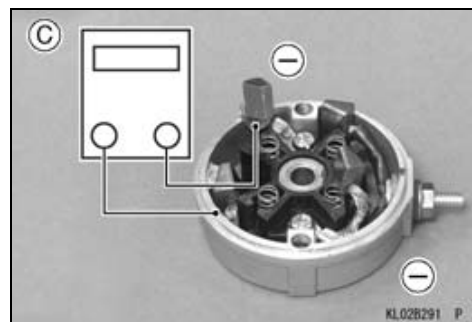
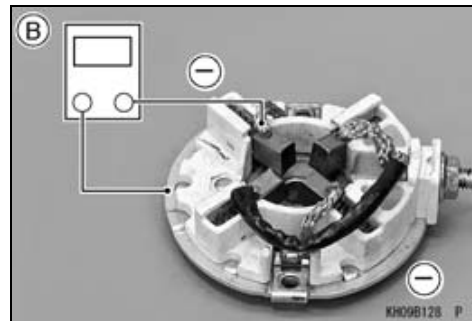
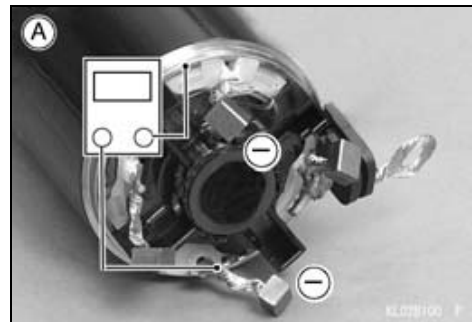

#### Pinion Clutch Inspection

##### FX Models

- Remove the pinion clutch.
  - Turn the pinion gear [A] by hand. The pinion gear should turn counterclockwise freely, but should not turn clockwise.
- ★ If the pinion clutch does not operate as it should, or if it makes noise, replace the pinion clutch.

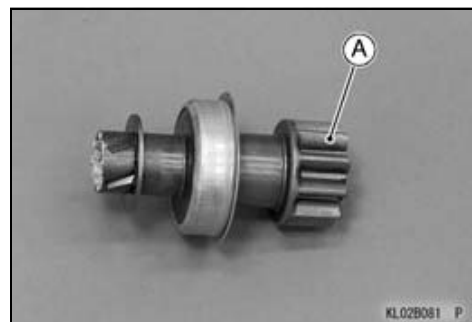

## Electric Starter System

### Recoil Starter Removal

- Remove:
  - Recoil Starter Mounting Bolts [A]
  - Recoil Starter [B]

FX Models [C]

FS Models [D]

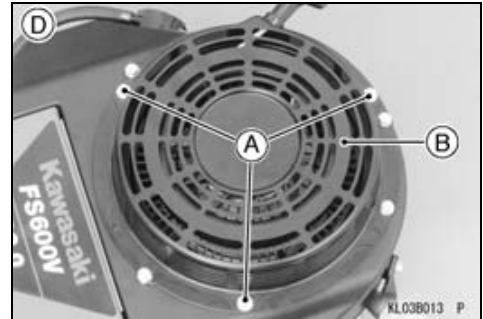
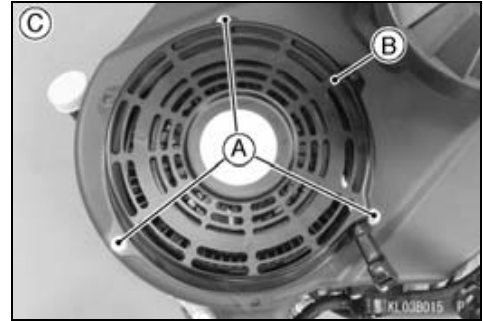

### Recoil Starter Installation

- Install the recoil starter [A] and tighten the mounting bolts [B].

**Torque - Recoil Starter Mounting Bolts: 5.9 N·m (0.60 kgf·m, 52 in·lb)**

FX Models [C]

FS Models [D]

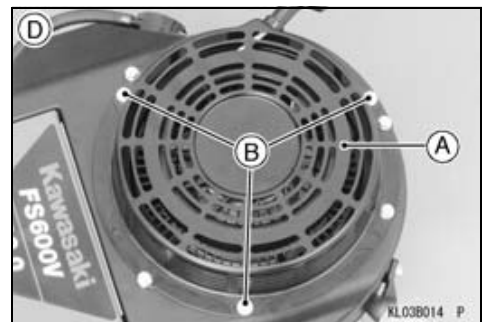
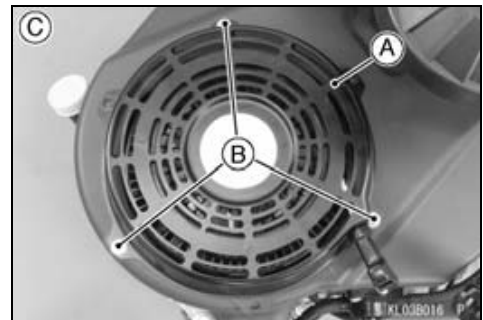

### Recoil Starter Disassembly

- Remove the recoil starter (see Recoil Starter Removal).
- Pull the handle [A] out 30 cm (1 ft), and clamp the rope [B] with the clip [C] so it can not wind back onto the reel [D].
- Pry the knot [E] out of the handle and untie it.
- Remove the handle from the rope.

#### **⚠ WARNING**

The recoil spring is under great tension and can travel at high speed if it comes loose and cause injury or pinch fingers. Wear gloves during reassembly to avoid injury.

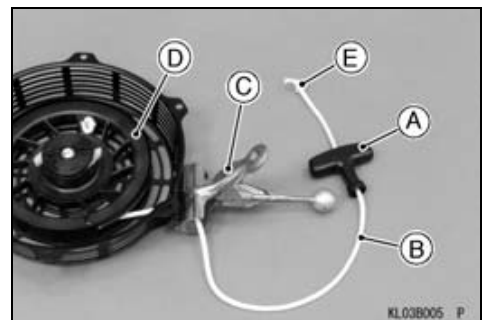

## 8-26 STARTER SYSTEM

### Electric Starter System

- While carefully holding the reel [A] and case [B], remove the clip.
- Unwind the spring tension slowly.

#### NOTE

○Do not wedge the rope between the reel and case.

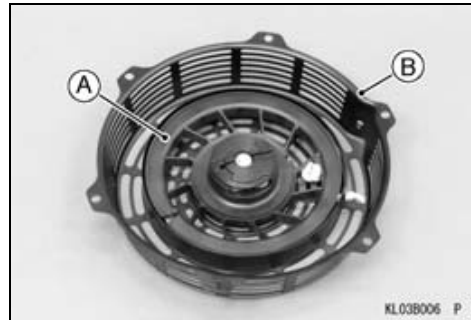

- Loosen the screw [A].
- Remove the retainer [B] with the snap ring [C].
- Remove the pawls [D].

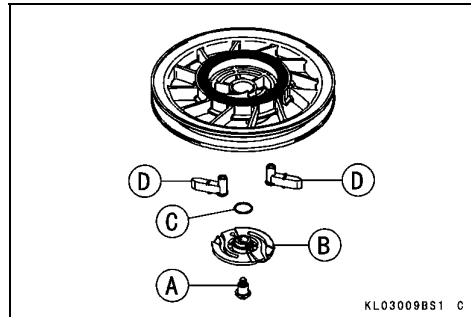

- Slowly lift the reel [A] straight up out of the case [B].

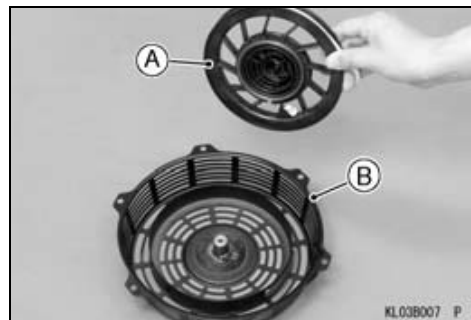

- Hold the reel [A] with spring side downward in a suitable container and tap reel to remove recoil spring [B].

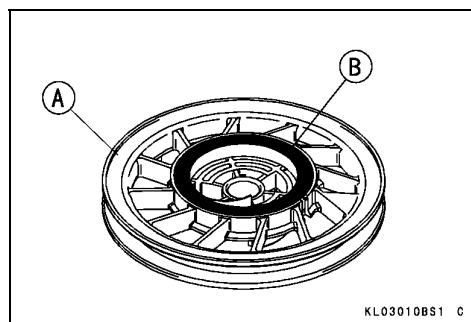

### Recoil Starter Assembly

#### WARNING

The recoil spring is under pressure and can be ejected with great force and cause injury. When installing the spring, wear gloves to help protect your hands. Use your thumb to keep pressure on the spring so that it does not come loose.

- Lightly grease the recoil spring.
- Set the recoil spring into the reel.

## Electric Starter System

- Wind the rope [A] clockwise [B] on the reel [C].

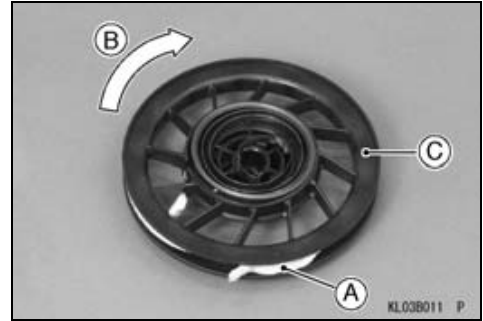

- Lightly grease the shaft [A].
- Install the reel [B] into the case [C].
- Hook the spring hook [D] to the case tab [E].
- Turn the reel clockwise until you feel the spring hook catches the case tab.

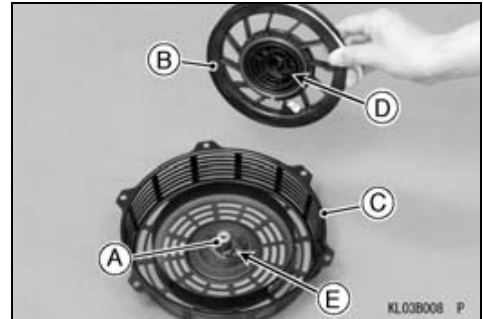

- Install the pawls [A].

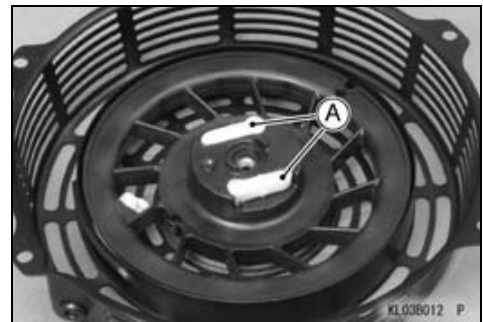

- Apply a non-permanent locking agent to the recoil starter retainer screw [A].
- Install the retainer assembly [B].
- Tighten:
  - Torque - Recoil Starter Retainer Screw: 5.9 N·m (0.60 kgf·m, 52 in·lb)**
- Turn the reel two turns counterclockwise to preload the recoil spring.

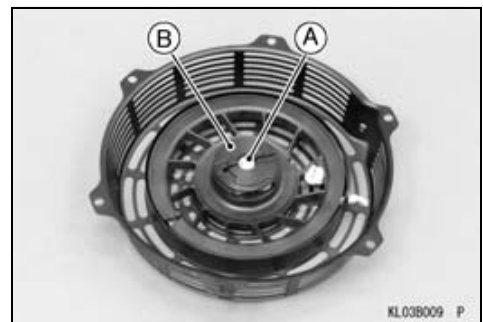

- While holding the reel to keep it from unwinding, feed the end of the rope through the hole in the case.
- Clip the rope as shown to hold it.
- Install the handle [A], and secure it with a knot [B].
- Remove the clip [C] to release the rope.

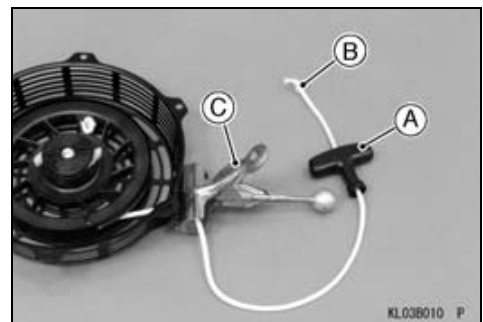



# Electrical System

## Table of Contents

Exploded View.....	9-2
Specifications .....	9-6
Special Tool .....	9-7
Wiring Diagram.....	9-8
Precautions.....	9-11
Charging System.....	9-12
Flywheel and Stator Coil Removal.....	9-12
Flywheel and Stator Coil Installation.....	9-16
Charging System Operational Inspection .....	9-20
Stator Coil Resistance .....	9-20
Unregulated Stator Output.....	9-21
Regulator Removal .....	9-21
Regulator Installation .....	9-22
Regulator Resistance.....	9-22
Ignition System.....	9-23
Ignition Coil Removal .....	9-24
Ignition Coil Installation .....	9-25
Ignition Coil Inspection.....	9-26
Spark Plug Removal .....	9-26
Spark Plug Installation .....	9-26
Spark Plug Cleaning and Inspection.....	9-26
Spark Plug Gap Inspection .....	9-26

# 9-2 ELECTRICAL SYSTEM

## Exploded View

### Electric Starter Model

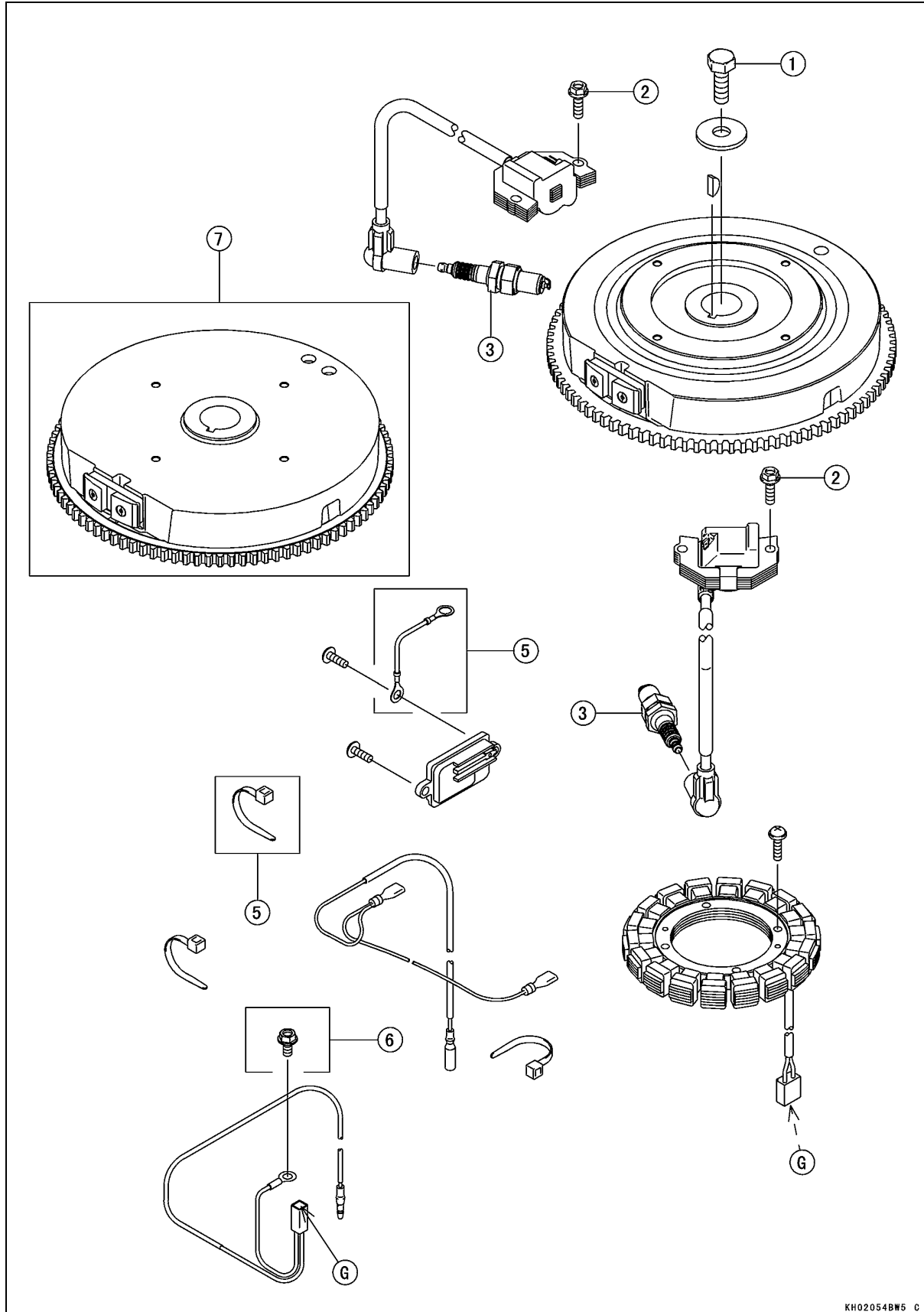

**ELECTRICAL SYSTEM 9-3**

**Exploded View**

No.	Fastener	Torque			Remarks
		N·m	kgf·m	ft·lb	
1	Flywheel Bolt	56	5.7	41	
2	Ignition Coil Bolts	5.9	0.60	52 in·lb	
3	Spark Plugs	22	2.2	16	
4	Stator Coil Screws	3.4	0.35	30 in·lb	

- 5. FS and FR Models
  - 6. FR Models
  - 7. FR541/600V-AS00 ~ CS00 Models
- G: Apply dielectric grease.

# 9-4 ELECTRICAL SYSTEM

## Exploded View

### Recoil Starter Model

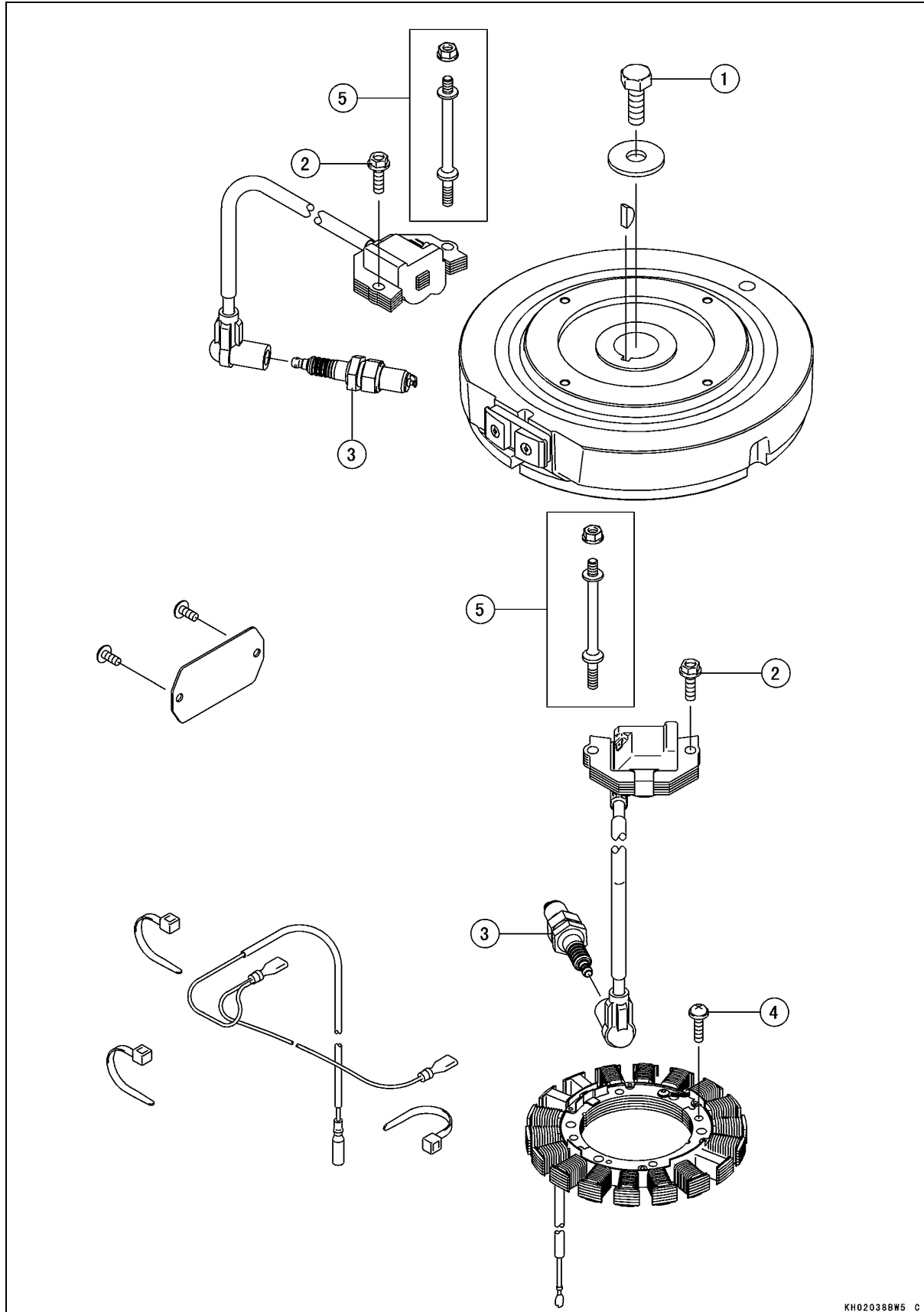

## ELECTRICAL SYSTEM 9-5

### Exploded View

No.	Fastener	Torque			Remarks
		N·m	kgf·m	ft·lb	
1	Flywheel Bolt	56	5.7	41	
2	Ignition Coil Bolts	5.9	0.60	52 in·lb	
3	Spark Plugs	22	2.2	16	
4	Stator Coil Screws	3.4	0.35	30 in·lb	

5. FS Models

## 9-6 ELECTRICAL SYSTEM

### Specifications

Item	Standard	Service Limit
<b>Charging System</b>		
Regulated Output Voltage (Electric Starter Model only)	14.1 V DC	15 V DC
Stator Coil Resistance:		
Electric Starter Model	0.1 ~ 0.14 $\Omega$	---
Recoil Starter Model	4.4 ~ 15 $\Omega$	---
Unregulated Stator Output (Electric Starter Model only)	26 ~ 34 V AC/3 000 rpm	26 V AC/3 000 rpm
Regulator Resistance (Electric Starter Model only)	in the text	---
<b>Ignition System</b>		
Ignition Coil:		
Air Gap	0.2 ~ 0.4 mm (0.008 ~ 0.016 in.)	
Primary Winding Resistance	in the text	---
Secondary Winding Resistance	in the text	---
Spark Plug	NGK BPR4ES	---
Plug Gap	0.7 ~ 0.8 mm (0.028 ~ 0.031 in.)	---

Special Tool

Hand Tester:  
57001-1394

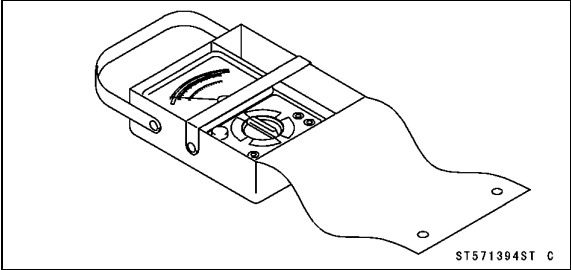

# 9-8 ELECTRICAL SYSTEM

## Wiring Diagram

### Electric Starter Model (FX Models)

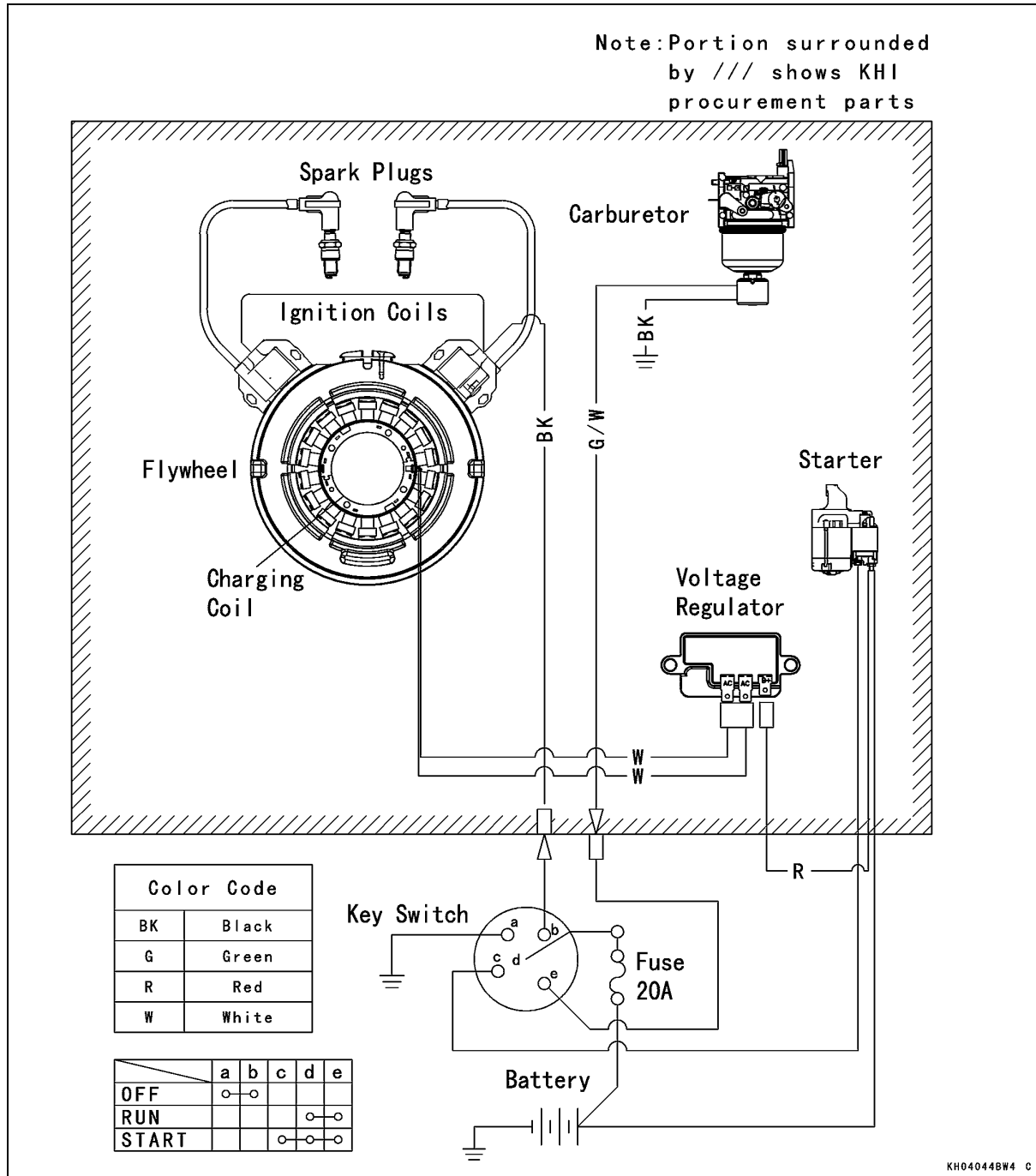

Wiring Diagram

Electric Starter Model (FS and FR Models)

Note: Portion surrounded by /// shows KHI procurement parts

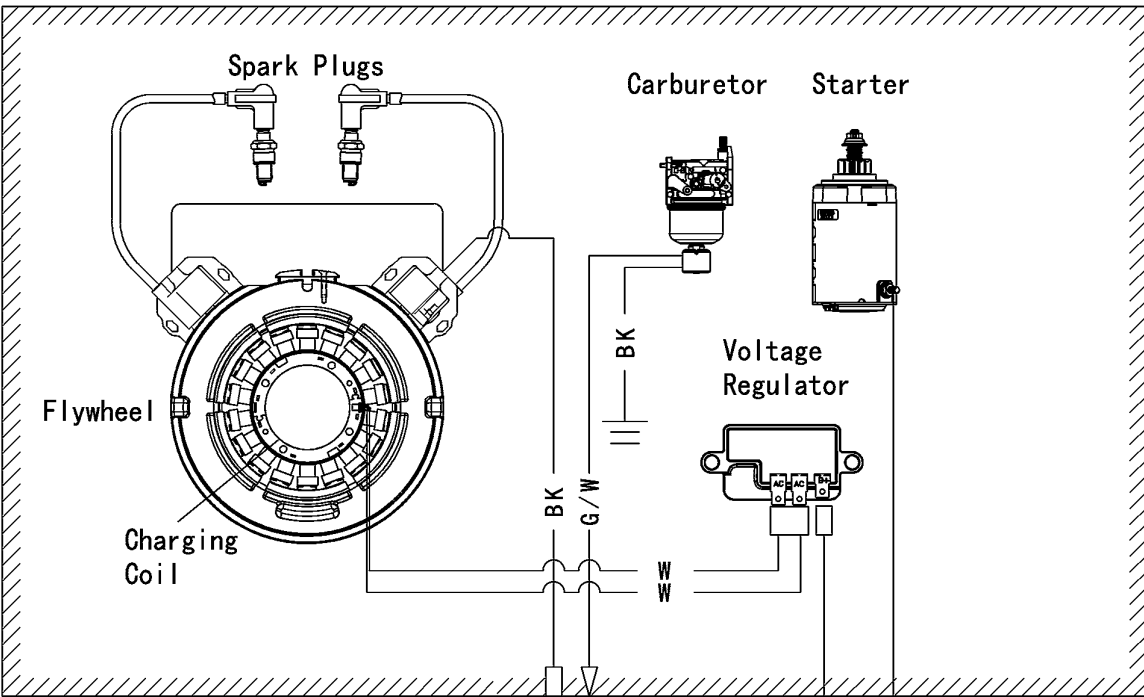

Color Code	
BK	Black
G	Green
R	Red
W	White

	a	b	c	d	e
OFF	○	○			
RUN				○	○
START			○	○	

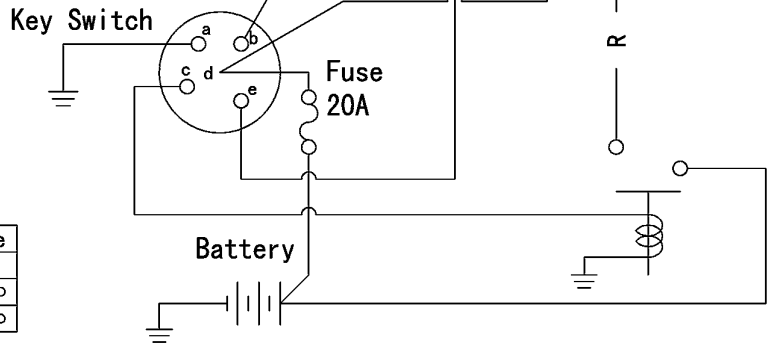

# 9-10 ELECTRICAL SYSTEM

## Wiring Diagram

### Recoil Starter Model

Note: Portion surrounded by /// shows KHI procurement parts

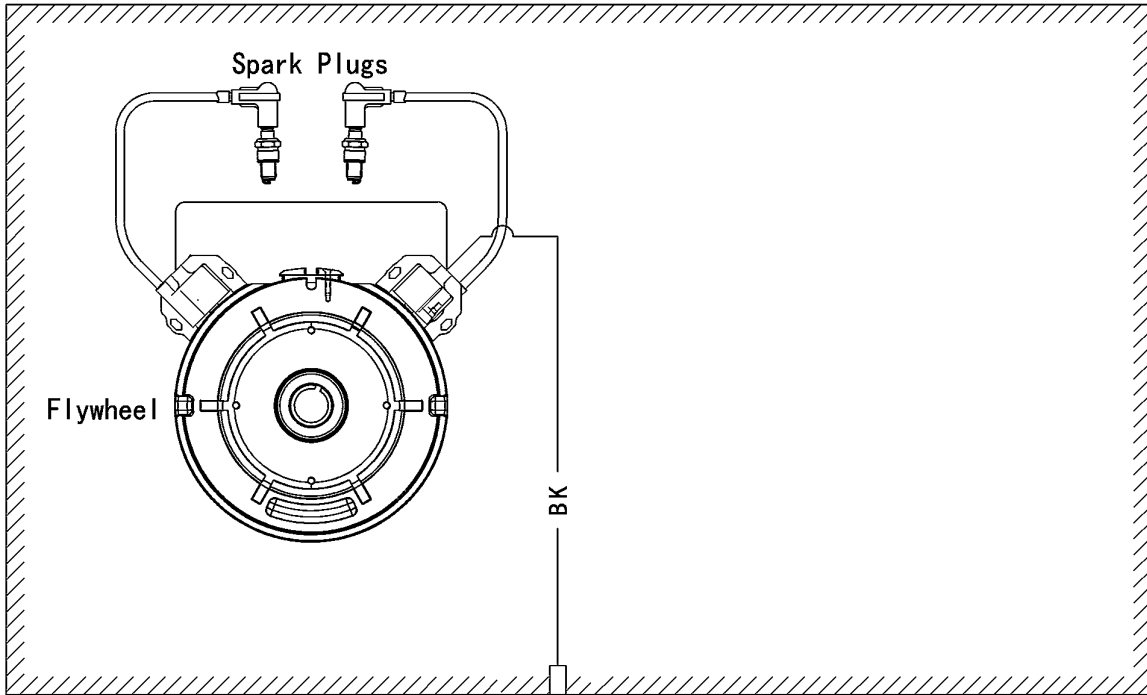

Color Code	
BK	Black



## Precautions

There are a number of important precautions that you must follow when servicing electrical systems. Learn and observe all the rules below.

- Do not reverse the battery cable connections. This will burn out the diodes in the electrical parts.
- Always check the battery condition before judging other parts of the electrical system. A fully charged battery is necessary for conducting accurate electrical system tests.
- Do not hit the electric parts with a hammer or do not drop the electric parts. These may result in the electric parts damage or breakage.
- To prevent damage to electrical parts, do not disconnect the battery cables or any other electrical connections when the engine switch is on, or while the engine is running.
- Because of the large amount of current, never keep the engine switch turned to the start position when the starter motor will not start, or the current may burn out the starter motor windings.
- Take care not to short the leads that are directly connected to the battery positive (+) terminal to the chassis ground.
- Troubles may involve one or all items in some cases. Never replace a defective part without determining what CAUSED the failure. If the failure was occurred by another item or some other items, repair and/or replace the item(s). Or the failure may happen again.
- Make sure all connectors in the circuit are clean and tight, and examine the leads for signs of burning, fraying, etc. Poor leads and bad connections will affect electrical system operation.
- Measure the coil and the winding resistance when the parts are cold (at room temperature).
- Electrical connectors:

Connectors [A]

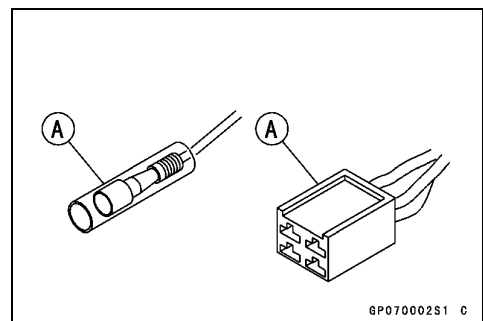

Connectors [B]

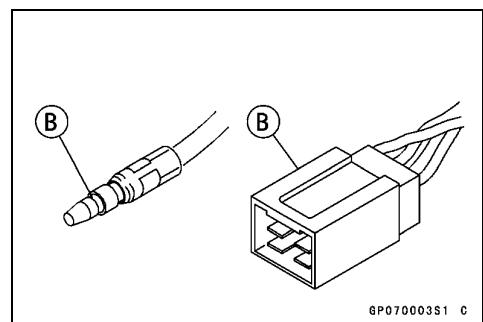

## 9-12 ELECTRICAL SYSTEM

### Charging System

#### ***Flywheel and Stator Coil Removal***

##### **Electric Starter Model (FX Models)**

- Remove:
  - Air Cleaner (see Air Cleaner Body and Bracket Removal in the Fuel System chapter)
  - Fuel Pump (see Fuel Pump Removal in the Fuel System chapter)
  - Stator Coil Lead Connector (see Regulator Removal)
  - Bolts [A] and Guard [B]

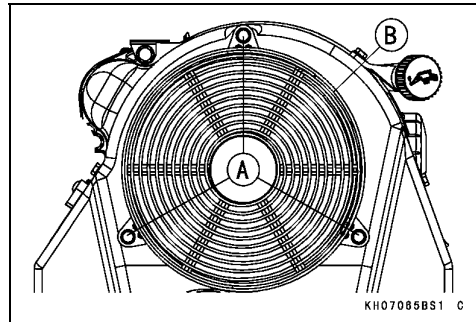

##### **Electric Starter Model (FR541/600V-AS00 ~ CS00 Models)**

- Remove:
  - Element Assembly (see Element Removal in the Fuel System chapter)
  - Fuel Pump (see Fuel Pump Removal in the Fuel System chapter)
  - Stator Coil Lead Connector (see Regulator Removal)
  - Bolts [A]
  - Fan Housing [B]

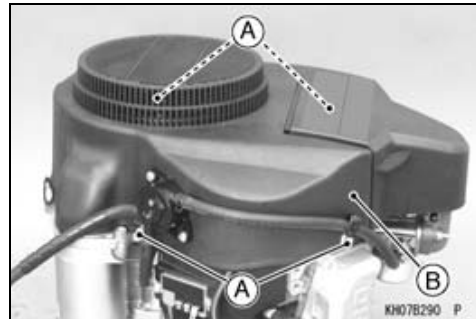

##### **Electric Starter Model (FS and FR541/600V-DS00 Models)**

- Remove:
  - Element Assembly (see Element Removal in the Fuel System chapter)
  - Fuel Pump (see Fuel Pump Removal in the Fuel System chapter)
  - Stator Coil Lead Connector (see Regulator Removal)
  - Screw Rivets [A] and Guard [B]

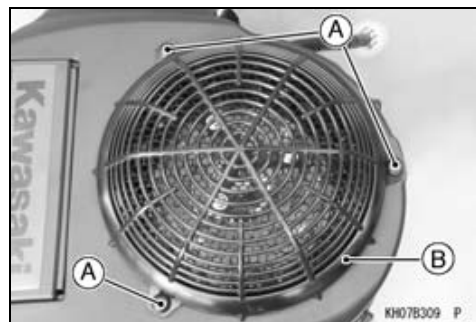

##### **Electric Starter Model (FR541/600V-AS00 ~ CS00 Models)**

- Remove:
  - Bolts [A]
  - Screen [B]

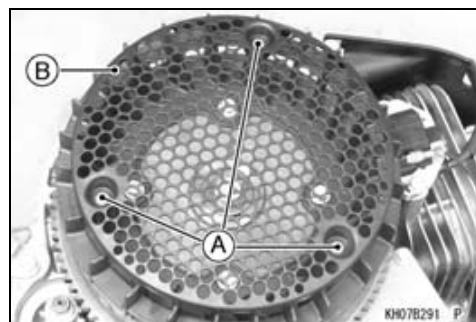

##### **Electric Starter Model (FX and FS481/541/600V-ES00, FR541/600V-DS00 Models)**

- Remove:
  - Screws [A] and Screen [B]
  - Spacer

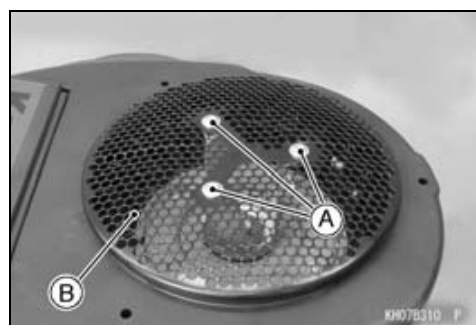

## Charging System

- Remove:
  - Bolts [A]
  - Fan Housing [B]

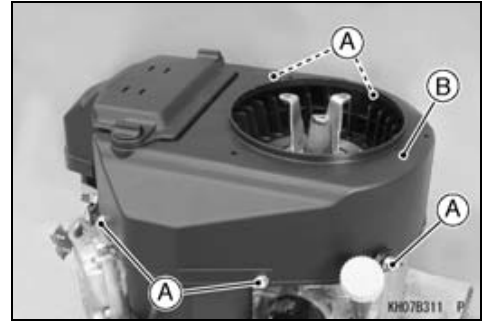

### Electric Starter Model (FX and FS481/541/600V-AS00 ~ DS00, FR541/600V-AS00 ~ CS00 Models)

- Remove:
  - Ignition Coils [A] (see Ignition Coil Removal)
  - Bolts [B]
  - Cooling Fan [C]

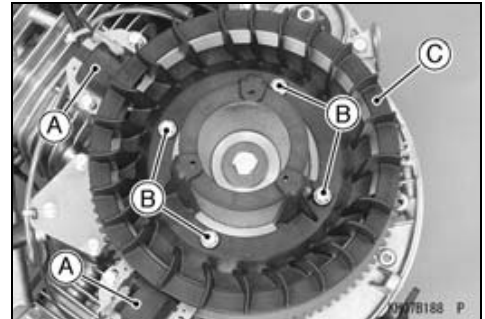

- Hold the flywheel with a suitable tool [A], remove the flywheel bolt [B] and washer.

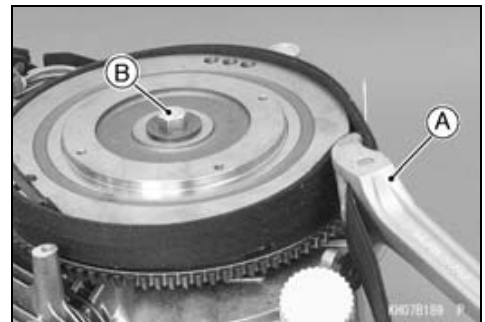

### Electric Starter Model (FS481/541/600V-ES00 and FR541/600V-DS00 Models)

- Remove the ignition coils (see Ignition Coil Removal).
- Hold the flywheel with a suitable tool, remove the flywheel bolt [A] and bracket [B], washer.
- Remove:
  - Bolt [C]
  - Plate [D]
  - Cooling Fan [E]

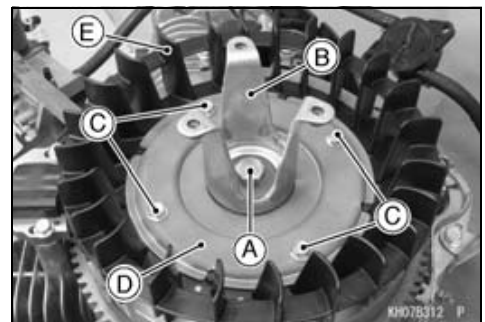

### Electric Stater Model (FS and FX, FR Models)

- Using a suitable flywheel puller [A], remove the flywheel [B].

#### **NOTICE**

**Always use flywheel puller.**



## 9-14 ELECTRICAL SYSTEM

### Charging System

#### Electric Starter Model (FX Models)

- Free the stator coil lead [A], stop switch lead [B] and solenoid valve connector lead [C] from the engine shroud clamp [D].

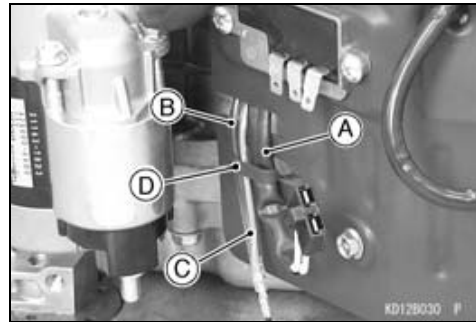

#### Electric Starter Model (FS and FR Models)

- Cut off the band [A].

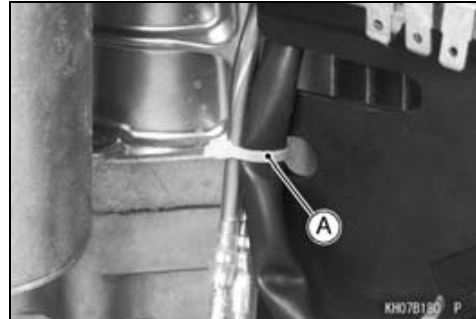

#### Electric Starter Model (FS and FX, FR Models)

- Remove:
  - Woodruff Key [A]
  - Stator Coil Screws [B]
  - Stator Coil [C]

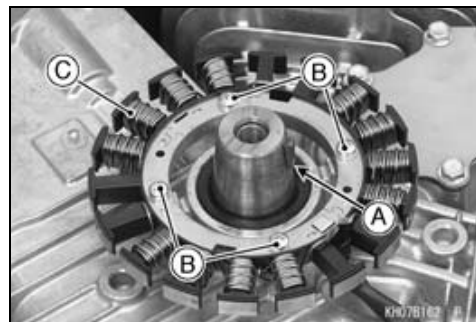

#### Recoil Starter Model (FX Models)

- Remove:
  - Recoil Starter (see Recoil Starter Removal in the Starter System chapter)
  - Air Cleaner (see Air Cleaner and Bracket Removal in the Fuel System chapter)
  - Fuel Pump (see Fuel Pump Removal in the Fuel System chapter)
  - Bolts [A]
  - Fan Housing [B]

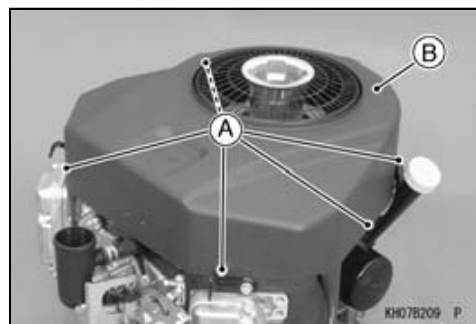

#### Recoil Starter Model (FS Models)

- Remove:
  - Recoil Starter (see Recoil Starter Removal in the Starter System chapter)
  - Element Assembly (see Element Removal in the Fuel System chapter)
  - Fuel Pump (see Fuel Pump Removal in the Fuel System chapter)
  - Nuts [A]
  - Recoil Starter Plate [B]
  - Bolts [C]
  - Fan Housing [D]

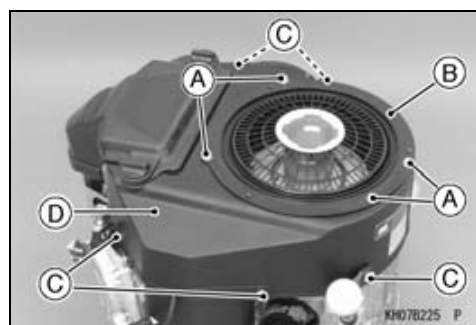

## Charging System

- Remove the fan housing stud bolts [A].

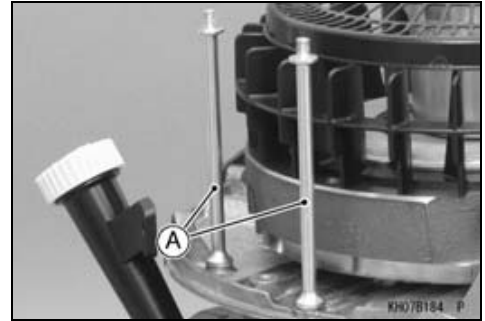

### Recoil Starter Model (FS and FX Models)

- Remove the ignition coils (see Ignition Coil Removal).
- Hold the flywheel with a suitable tool [A], remove the flywheel bolt and washer.
- Remove the pulley [B] with the screen [C].

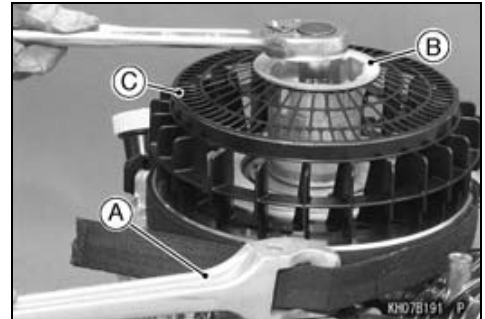

- Remove:
  - Pulley Plate [A]
  - Bolts [B]
  - Cooling Fan Plate [C]
  - Cooling Fan [D]

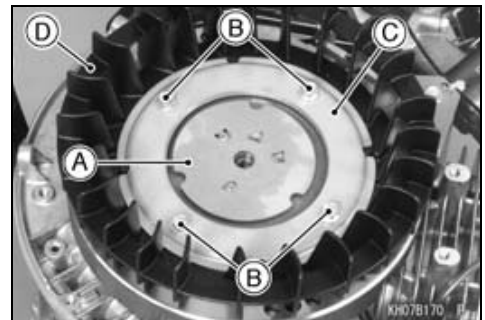

- Using a suitable flywheel puller [A], remove the flywheel [B].

<b>NOTICE</b>
<b>Always use flywheel puller.</b>

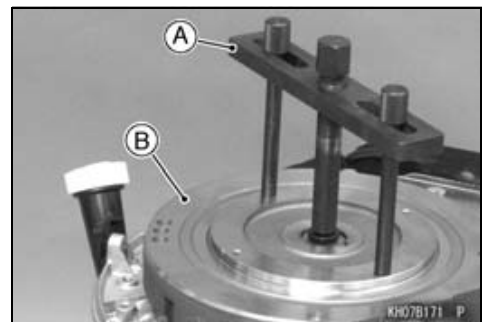

### Recoil Starter Model (FX Models)

- Free the stator coil lead [A] and stop switch lead [B] from the engine shroud clamp [C].

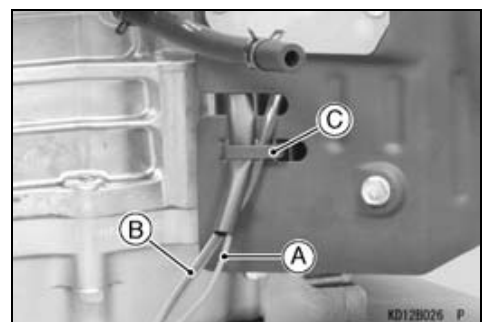

## 9-16 ELECTRICAL SYSTEM

### Charging System

#### Recoil Starter Model (FS Models)

- Cut off the band [A].

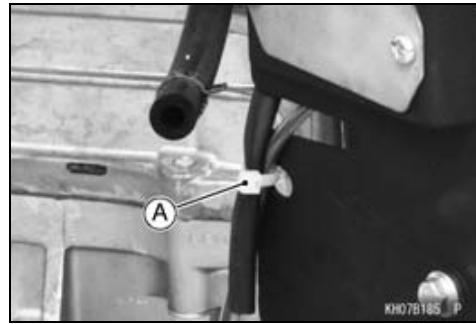

#### Recoil Starter Model (FS and FX Models)

- Remove:
  - Woodruff Key [A]
  - Stator Coil Screws [B]
  - Stator Coil [C]

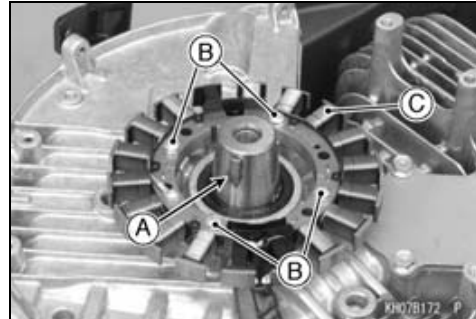

#### *Flywheel and Stator Coil Installation*

##### Electric Starter Model (FS and FX, FR Models)

- Install the stator coil and tighten the screws.
  - Torque - Stator Coil Screws: 3.4 N·m (0.35 kgf·m, 30 in·lb)**
- Using a cleaning fluid, clean off any oil or dirt on the following portions and dry them with a clean cloth.
  - Crankshaft Tapered Portion [A]
  - Flywheel Tapered Portion [B]
- Fit the woodruff key [C] securely in the slot in the crankshaft before installing the flywheel.
- Install the flywheel onto the crankshaft taper so that the woodruff key fits in the key way in the hub of the flywheel.

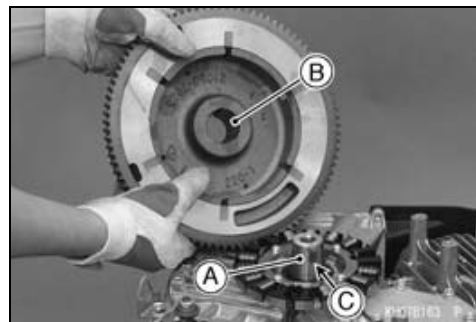

##### Electric Starter Model (FX and FS481/541/600V-AS00 ~ DS00, FR541/600V-AS00 ~ CS00 Models)

- Put the washer [A] as shown so that the "0" mark [B] faces up.
- Tighten:
  - Torque - Flywheel Bolt [C]: 56 N·m (5.7 kgf·m, 41 ft·lb)**
- Install the ignition coils (see Ignition Coil Installation).

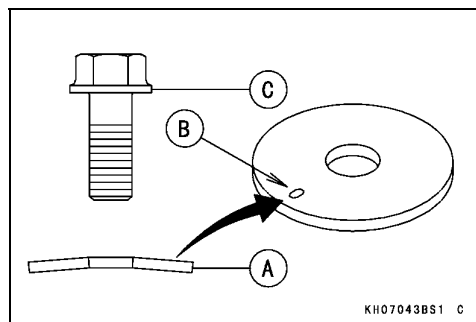

## Charging System

- Install the cooling fan [A].
- Tighten:
  - Torque - Cooling Fan Mounting Bolts [B]: 8.8 N·m (0.90 kgf·m, 78 in·lb)**

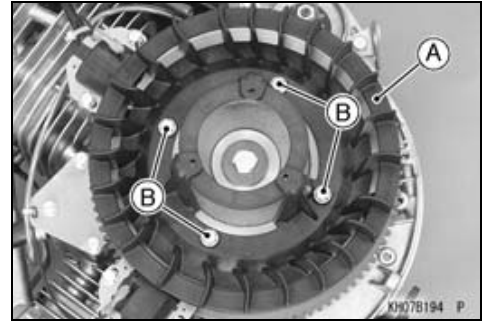

### Electric Starter Model (FS481/541/600V-ES00 and FR541/600V-DS00 Models)

- Install the cooling fan [A] and plate [B].
- Tighten:
  - Torque - Cooling Fan Mounting Bolts [C]: 8.8 N·m (0.90 kgf·m, 78 in·lb)**
- Install the bracket [D].
- Install the washer, tighten the bolt [E].
- Torque - Flywheel Bolt: 56 N·m (5.7 kgf·m, 41 in·lb)**
- Install the ignition coils (see Ignition Coil Installation).

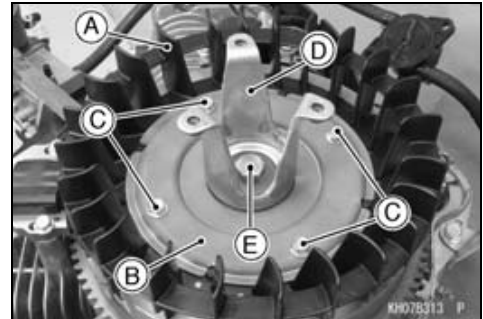

### Electric Starter Model (FX Models)

- Attach the stator coil lead [A], stop switch lead [B] and solenoid valve connector lead [C] to the engine shroud clamp [D] as shown in the figure.

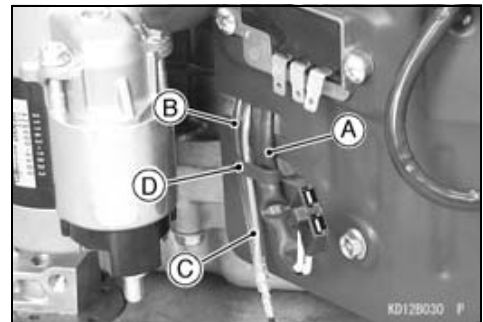

### Electric Starter Model (FS and FR Models)

- Attach the stator coil lead [A], stop switch lead and solenoid valve connector lead to the engine shroud with the band [B].

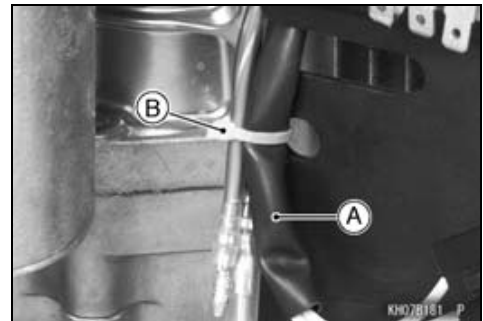

### Electric Starter Model (FS and FX, FR541/600V-DS00 Models)

- Install the fan housing.
- Tighten:
  - Torque - Fan Housing Bolts (FX Models): 5.9 N·m (0.60 kgf·m, 52 in·lb)**
  - Fan Housing Bolts (FS and FR541/600V-DS00 Models): 8.8 N·m (0.90 kgf·m, 78 in·lb)**
- Install the cooling fan screen.
- Tighten:
  - Torque - Cooling Fan Screen Screws: 3.0 N·m (0.31 kgf·m, 27 in·lb)**

## 9-18 ELECTRICAL SYSTEM

### Charging System

#### Electric Starter Model (FX Models)

- Install the guard [A] and tighten the bolts [B].  
Torque - Guard Mounting Bolts: 5.9 N·m (0.60 kgf·m, 52 in·lb)

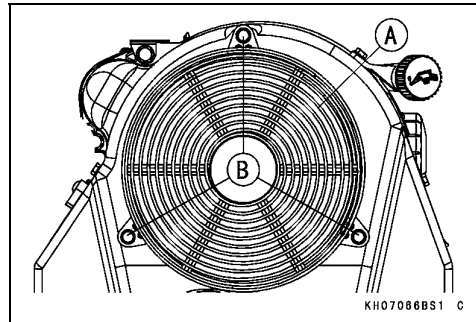

#### Electric Starter Model (FS and FR541/600V-DS00 Models)

- Install the guard [A] and screw rivets [B].

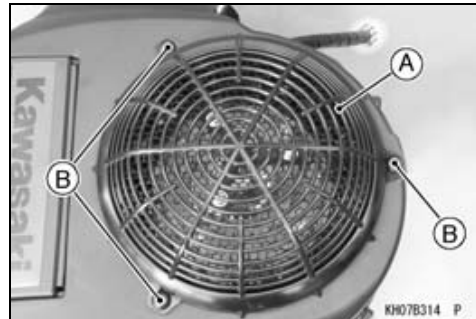

- Install the removed parts (see appropriate chapters).

#### Recoil Starter Model (FS and FX Models)

- Install the stator coil and tighten the screws.  
Torque - Stator Coil Screws: 3.4 N·m (0.35 kgf·m, 30 in·lb)
- Using a cleaning fluid, clean off any oil or dirt on the following portions and dry them with a clean cloth.  
Crankshaft Tapered Portion [A]  
Flywheel Tapered Portion [B]
- Fit the woodruff key [C] securely in the slot in the crankshaft before installing the flywheel.
- Install the flywheel onto the crankshaft taper so that the woodruff key fits in the key way in the hub of the flywheel.

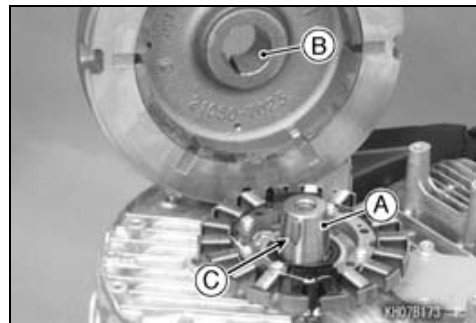

- Install the cooling fan [A].
- Install the plate [B] so that the slits [C] fit to the bosses [D] on the fan.
- Tighten:

Torque - Cooling Fan Plate Mounting Bolts: 8.8 N·m (0.90 kgf·m, 78 in·lb)

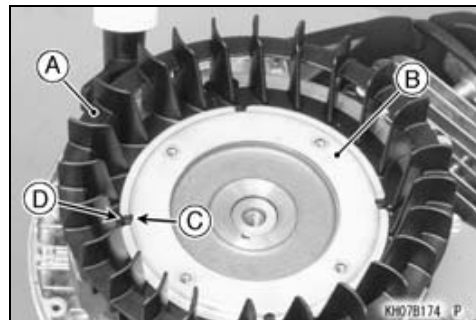

## Charging System

- Install the pulley plate [A] so that the notch [B] inserts into the slot [C] in the flywheel.

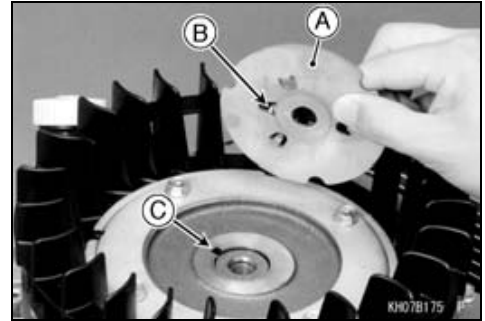

- Install the pulley [A] with the screen [B] so that the tabs [C] of the plate [D] fit into the holes [E].

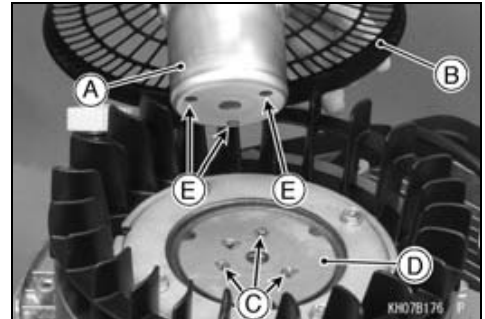

- Put the washer [A] as shown so that the “0” mark [B] faces up.
- Tighten:  
**Torque - Flywheel Bolt [C]: 56 N·m (5.7 kgf·m, 41 in·lb)**
- Install the ignition coils (see Ignition Coil Installation).

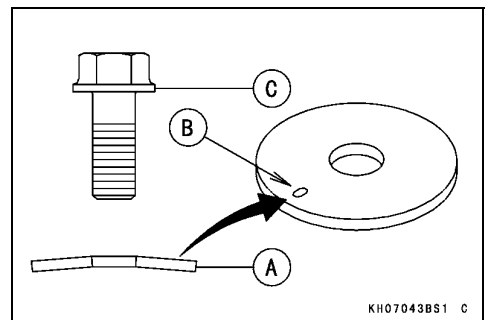

### Recoil Starter Model (FX Models)

- Attach the stator coil lead [A] and stop switch lead [B] to the engine shroud clamp [C] as shown in the figure.

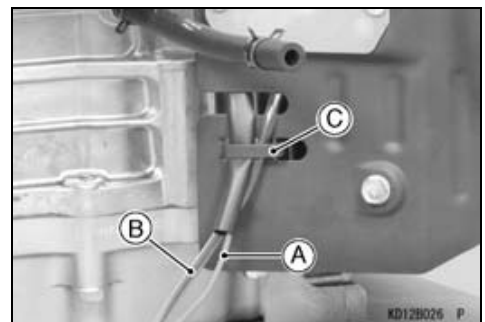

### Recoil Starter Model (FS Models)

- Attach the stator coil lead [A] and stop switch lead [B] to the engine shroud with the band [C].

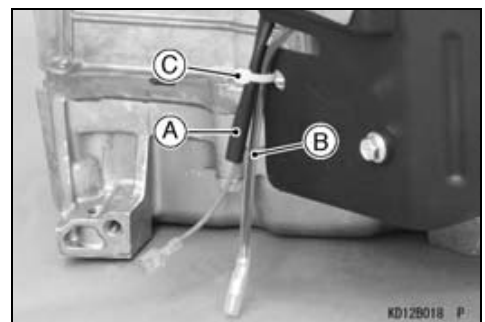

## 9-20 ELECTRICAL SYSTEM

### Charging System

#### Recoil Starter Model (FS and FX Models)

- Install the crankcase stud bolts and tighten them [FS Models (Recoil Starter Model only)].
- Install the fan housing and tighten the bolts.

**Torque - Fan Housing Bolts (FX Models): 5.9 N·m (0.60 kgf·m, 52 in·lb)**

**Fan Housing Bolts (FS Models): 8.8 N·m (0.90 kgf·m, 78 in·lb)**

- Install the recoil starter plate and tighten the nut [FS Models (Recoil Starter Model only)].
- Install the removed parts (see appropriate chapter).

#### Charging System Operational Inspection

##### Electric Starter Model

- Check the battery condition.

#### NOTE

○Always check the battery condition before judging other parts of the charging system. The battery must be fully charged for accurate charging system tests.

- Warm up the engine to bring the components up to their normal operating temperatures.
- Measure regulated output voltage at various engine speeds.
- Connect a voltmeter across the battery terminals.
- ★The readings should show nearly battery voltage when the engine speed is low, and as the engine speed rises, the readings should also rise. But they must stay within the specified range.
- ★If the output voltage is much higher than the specification, the regulator is defective, or the regulator leads are loose or open.
- ★If the output voltage does not rise as the engine speed increase, the regulator is defective or the alternator output is insufficient for the loads.

**Regulated Output Voltage  
Battery Voltage to 15 V DC**

#### Stator Coil Resistance

- Disconnect the stator coil lead connector [A].
- Measure the stator coil resistance.

##### Electric Starter Model

- Connect a hand tester between stator pins [B].

**Special Tool - Hand Tester: 57001-1394**

##### Stator Coil Resistance

**0.1 ~ 0.14 Ω**

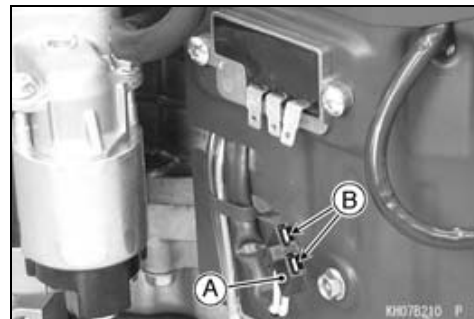

## Charging System

- Measure the stator coil resistance.

### Recoil Starter Model

- Connect a hand tester between the stator coil lead connector [A] and engine body.

**Special Tool - Head Tester: 57001-1394**

### Stator Coil Resistance

**4.4 ~ 15 Ω**

- ★ If the measured value is not within the specification, replace the stator coil with a new one.
- ★ If the coil has normal resistance, but the voltage inspection shows the alternator to be defective; the flywheel magnets have probably weakened, and the flywheel must be replaced.
- Check for continuity between each stator pin and ground. There should be no continuity (infinite ohm).
- ★ If the stator coil fails any of these tests, replace the coil with a new one.

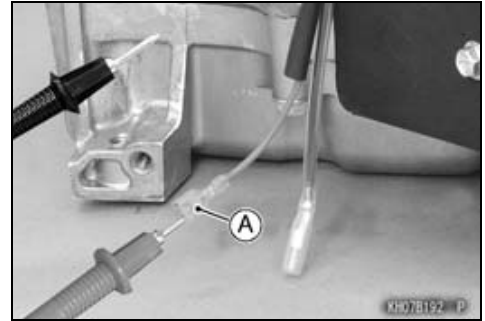

### Unregulated Stator Output

#### Electric Starter Model

- Disconnect the stator coil lead connector [A].
- Connect AC voltmeter to the stator pins [B].
- Start the engine. Run the engine at the 3 000 rpm speed.
- Voltage reading should be minimum 26 V AC/3 000 rpm.
- ★ If the AC voltage reading is less than the specification, replace the stator with a new one.

#### Unregulated Stator Output (MIN)

**26 V AC/3 000 rpm**

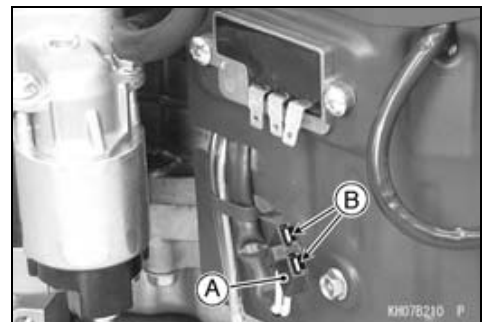

### Regulator Removal

#### Electric Starter Model

- Remove:
  - Stator Coil Lead Connector [A]
  - Regulator Mounting Screws [B]
  - Ground Lead [C] (FS Models only)
  - Regulator [D]

FX Models [E]

FS and FR Models [F]

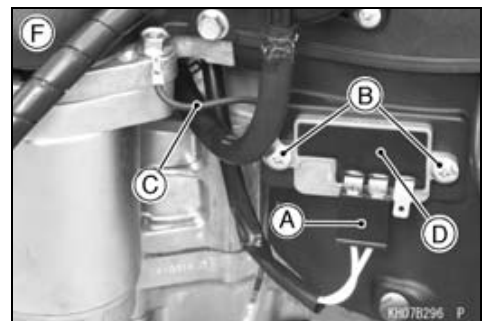
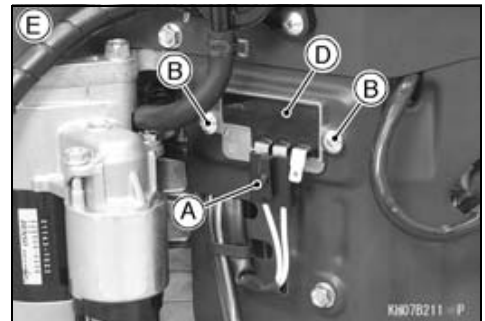

## 9-22 ELECTRICAL SYSTEM

### Charging System

#### Regulator Installation

##### Electric Starter Model

- Install:
  - Regulator [A]
  - Ground Lead [B] (FS Models only)
- Tighten the regulator mounting screws [C].
- Apply dielectric grease to the regulator terminals [D].
- Connect the stator coil lead connector [E].
  - FX Models [F]
  - FS and FR Models [G]

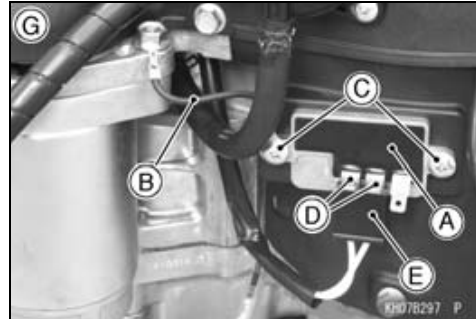
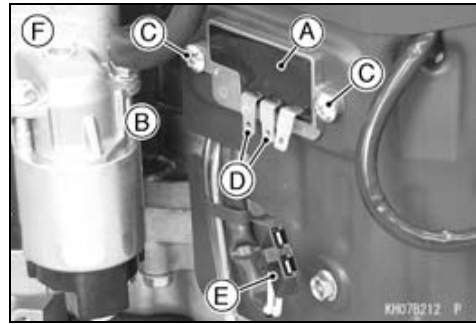

#### Regulator Resistance

##### Electric Starter Model

- Remove the regulator (see Regulator Removal).
- Set the KAWASAKI Hand Tester selector switch to the R × 100 Ω position.

**Special Tool - Hand Tester: 57001-1394**

- Connect the test leads to the points shown on the chart and read the resistance.

(Without Charging Monitor Type ...3 Blades)

	+	A	B	C	D
-					
A		-	∞	∞	∞
B		∞	-	0	∞
C		∞	0	-	∞
D		over than 1 MΩ	over than 1 MΩ	over than 1 MΩ	-

#### NOTE

○Resistance value may vary with individual meters.

#### NOTICE

Use only Tester 57001-1394 with new battery at room temperature for this test. A tester other than the Kawasaki Hand Tester should show different readings.

If a megger or a meter with a large capacity battery is used, the ignition coil will be damaged.

- ★ If the resistance is not as specified, replace the regulator with a new one.

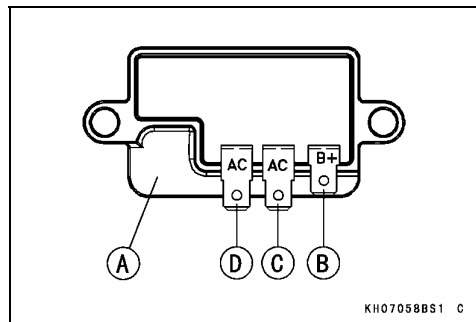

## Ignition System

This engine ignition is controlled by a solid state ignition assembly and requires no periodic maintenance except for the spark plugs.

The system consists of the following:

- Inductive Ignition Assemblies
- Permanent Magnet Flywheel
- Spark Plugs
- Stop Switch

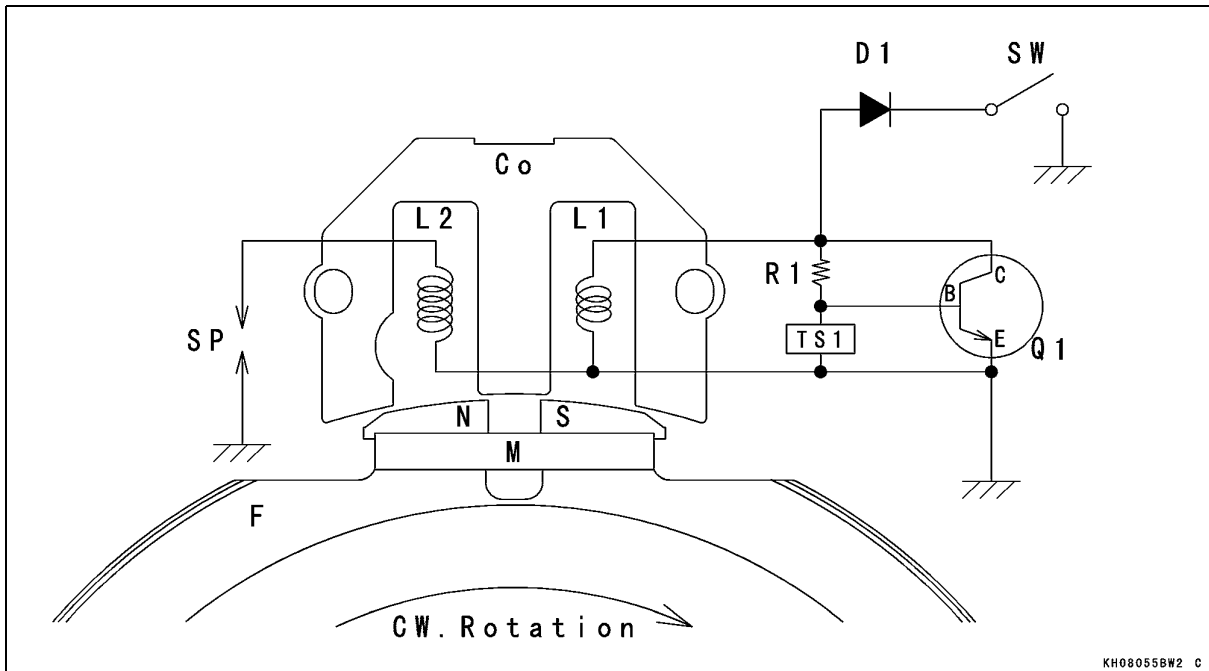

Co: Core (Lamination)  
 D1: Diode  
 L1: Primary Coil  
 L2: Secondary Coil  
 Q1: Transistor  
 B: Base

C: Collector  
 E: Emitter  
 R1: Control Resistor  
 TS1: Trigger Sensor  
 SP: Spark Plug  
 SW: Stop Switch

F: Flywheel  
 M: Magnet  
 N: North Pole  
 S: South Pole

### Ignition System Operation Theory

Permanent magnets are mounted around the edge area of a flywheel. As the flywheel (magnetic pole) rotates clockwise and passes the ignition module on a laminated core group, voltage is produced at the primary winding (L1), allowing a small bias current to flow from the control resistor (R1) to the transistor (Q1) base and thereby exciting the transistor base. Thus the transistor forms (turns ON) the primary circuit. This circuit current flows from the plus (+) side of the primary winding to ground through the transistor [Collector (C) to Emitter (E)].

When the base current is flowing, the trigger sensor (TS1) detects optimum time (peak current) to shut off the transistor base current. With the transistor rapidly shutting off the current at the primary coil, counter-electromotive force is generated and voltage in hundreds-of-volts is induced through the primary winding (L1), thereby producing extremely high voltage at the secondary winding (L2). When this secondary voltage steps up to k-volts, "ionization" meaning "ignition" occurs across the electrodes at the spark plug (SP).

The trigger sensor located internally in the ignition system is set to give constant ignition timing according to engine speed and temperature.

The diode (D1) located at the ignition shut-off circuit prevents misconnection of battery voltage, protecting the internal components of the ignition system. When the stop switch (SW) is set at the closed position, primary voltage is routed to ground, not allowing igniting operation.

## 9-24 ELECTRICAL SYSTEM

### Ignition System

#### ***Ignition Coil Removal***

- Remove the fan housing (see Flywheel and Stator Coil Removal).
- Cut off the band [A].
- Remove:
  - Spark Plug Cap [B]
  - Bolts [C]
  - Stop Switch Lead Connector [D]
  - Ignition Coil #1 [E]
  - Ignition Coil #2 [F]
  - Electric Starter Model/Recoil Starter Model (FX Models) [G]
  - Recoil Starter Model (FS Models) [H]

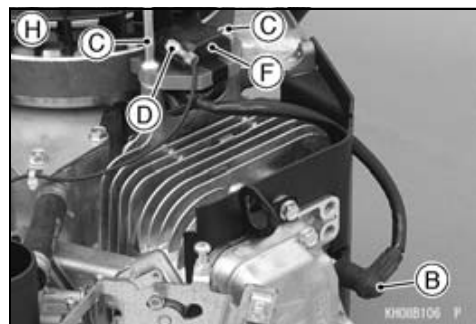
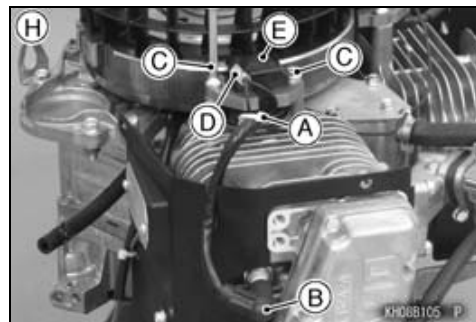
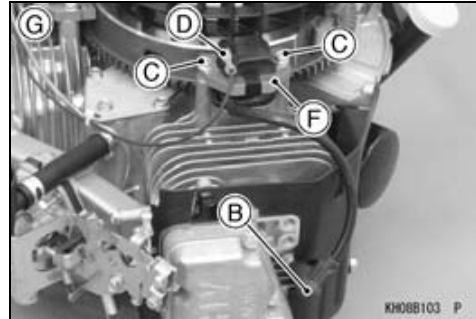
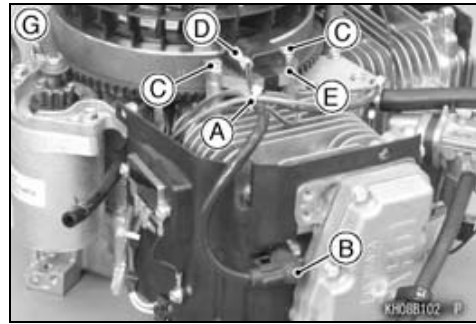

## Ignition System

### Ignition Coil Installation

- Install the ignition coil on the crankcase so that the stop switch lead connector [A] face the upward, and tighten bolt [B] first, then tighten bolt [C]. While tightening bolts, adjust the air gaps to specified gap value as shown.

[D]: between left leg of ignition coil and left pole-plate of magnet

[E]: between center of ignition coil and right pole-plate of magnet

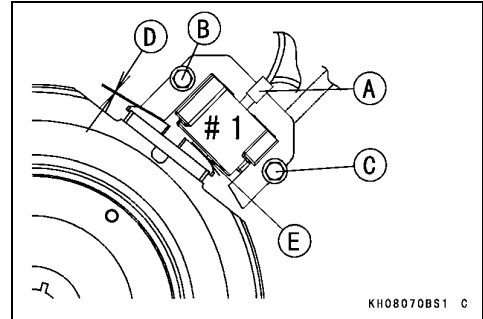

### Ignition Coil Air Gap

Standard: 0.2 ~ 0.4 mm (0.008 ~ 0.016 in.)

Torque - Ignition Coil Bolts: 5.9 N·m (0.60 kgf·m, 52 in·lb)

### NOTE

- Use the above procedure to insure proper coil air gap.

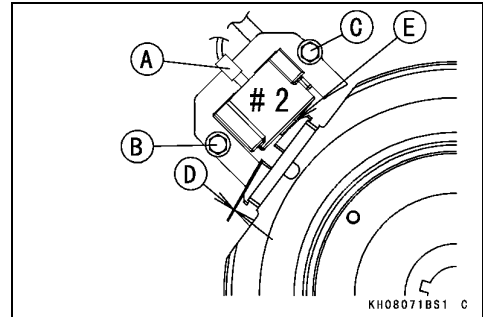

- Fit the ignition coil leads [A] to the each engine shroud groove [B].
- Install the spark plug cap [C].

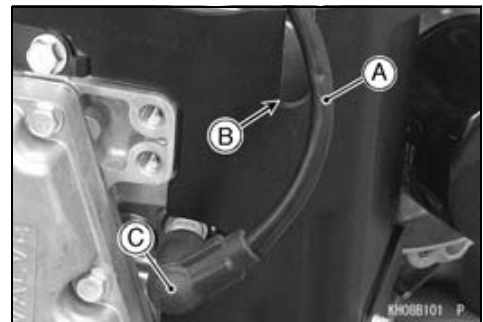

### Electric Starter Model

- Attach the solenoid valve connector lead [A] and stop switch lead [B] to the ignition coil lead [C] with the band [D].

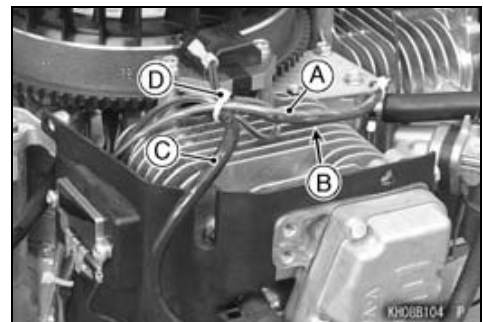

### Recoil Starter Model

- Attach the stop switch lead [A] to the ignition coil lead [B] with the band [C].

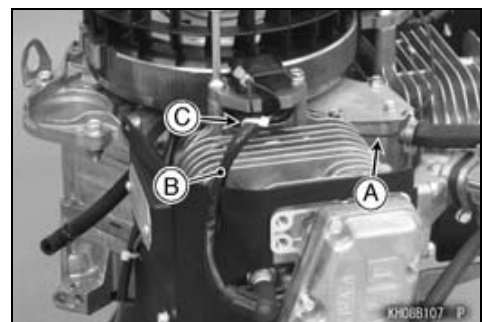

## 9-26 ELECTRICAL SYSTEM

### Ignition System

#### Ignition Coil Inspection

- Remove the ignition coil (see Ignition Coil Removal).
- Check the part number [D] listed.
- Measure the winding resistance as follows.
- Set the hand tester to the  $R \times 1 \text{ k}\Omega$  range.

**Special Tool - Hand Tester: 57001-1394**

- Measure the ignition coil winding resistance as shown in the table.

#### Ignition Coil Winding Resistance 21171-7047

	+	A	B	C
-				
A	-		3 ~ 13 k $\Omega$	10 ~ 20 k $\Omega$
B	$\infty$		-	$\infty$
C	10 ~ 20 k $\Omega$		18 ~ 28 k $\Omega$	-

#### Ignition Coil Winding Resistance 21171-0711

	+	A	B	C
-				
A	-		1 ~ 11 k $\Omega$	8 ~ 18 k $\Omega$
B	$\infty$		-	$\infty$
C	8 ~ 18 k $\Omega$		17 ~ 27 k $\Omega$	-

#### NOTICE

**Use only Tester 57001-1394 with new battery at room temperature for this test. A tester other than the Kawasaki Hand Tester should show different readings.**

**If a megger or a meter with a large capacity battery is used, the ignition coil will be damaged.**

- ★ If the tester does not read as specified, replace the coil with a new one.

#### Spark Plug Removal

- Carefully pull the plug caps from the spark plugs.
- Remove the spark plugs using a suitable plug wrench.

#### Spark Plug Installation

- Insert the spark plug vertically into the plug hole with the plug installed in the plug wrench.
- Tighten the plugs.

**Torque - Spark Plugs: 22 N·m (2.2 kgf·m, 16 ft·lb)**

- Fit the plug caps securely.
- Pull up the spark plug caps lightly to make sure of the installation of the spark plug caps.

#### Spark Plug Cleaning and Inspection

- Refer to the Spark Plug Cleaning and Inspection in the Periodic Maintenance chapter.

#### Spark Plug Gap Inspection

- Refer to the Spark Plug Gap Inspection in the Periodic Maintenance chapter.

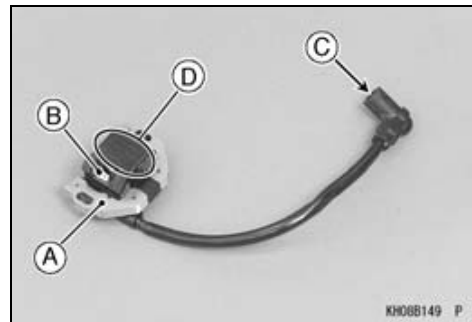

# Troubleshooting

## Table of Contents

Engine Troubleshooting Guide ..... 10-2  
Starter Motor Troubleshooting Guide ..... 10-6

## 10-2 TROUBLESHOOTING

### Engine Troubleshooting Guide

If the engine malfunctions, check if the way the engine is used is correct. If the engine malfunctions even if the engine is used correctly, systematically carry out troubleshooting starting with simple points.

This chart describes typical troubleshooting procedures.

Do not unnecessarily disassemble the carburetor, the magneto or the engine unless it has been found to be the cause of malfunctioning.

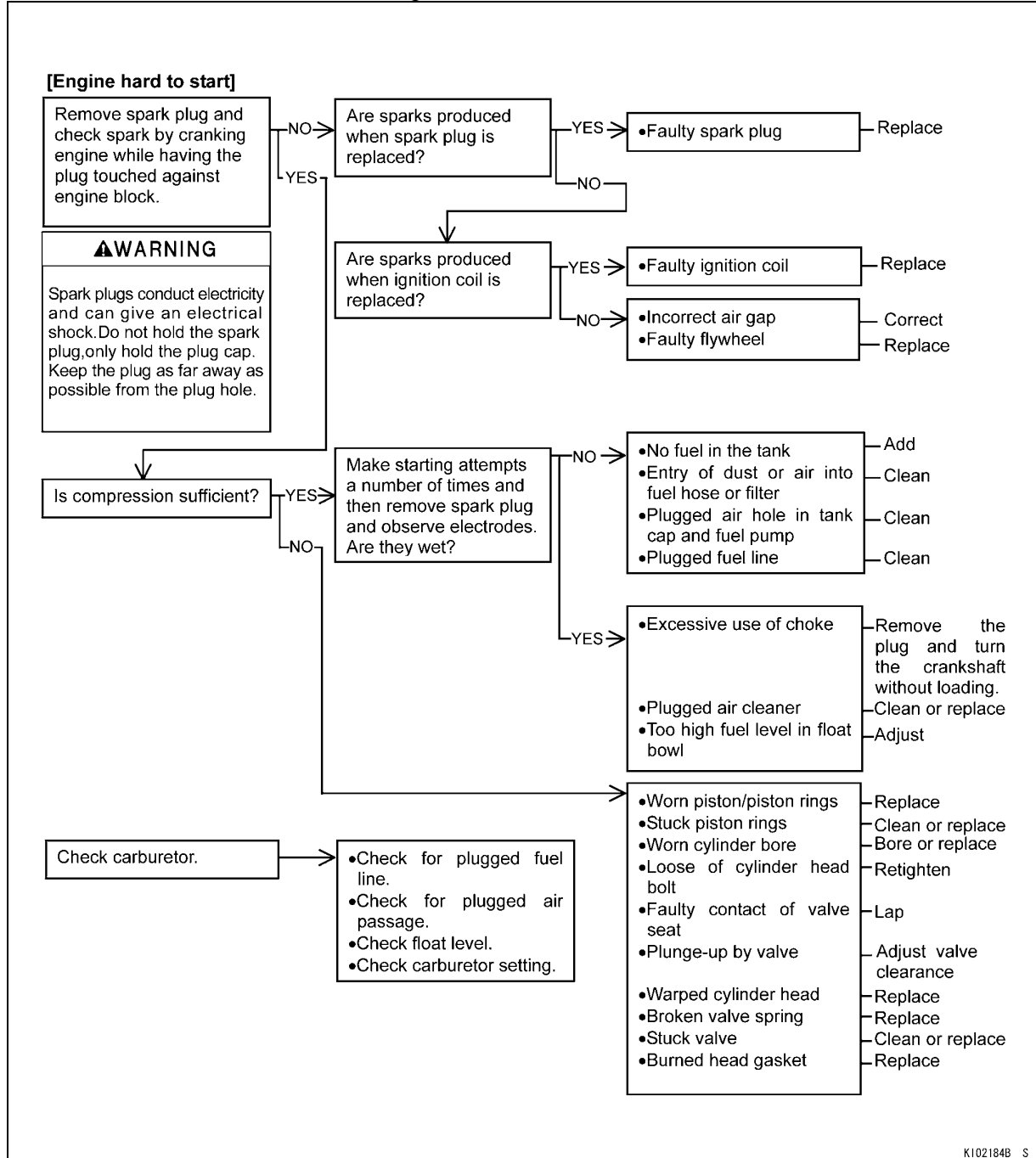

Engine Troubleshooting Guide

[Engine power loss]

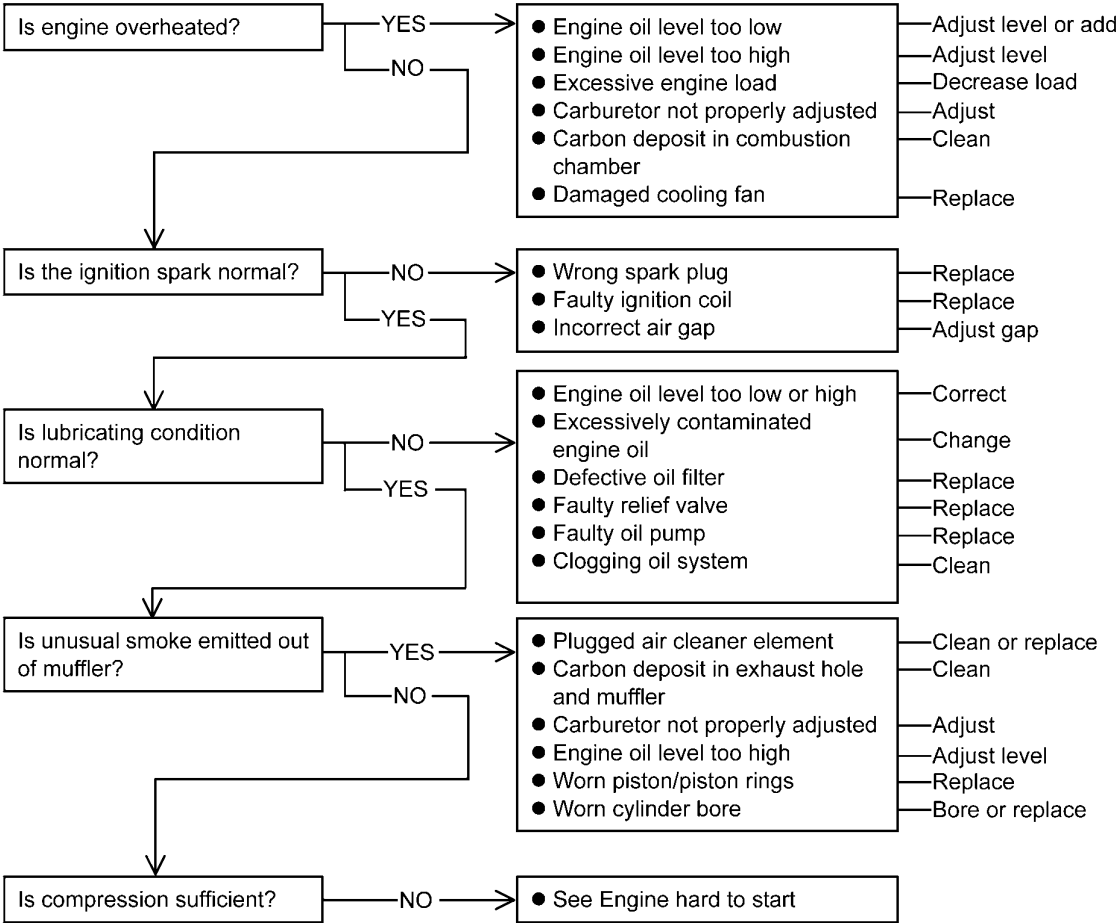

[Engine runs erratically]

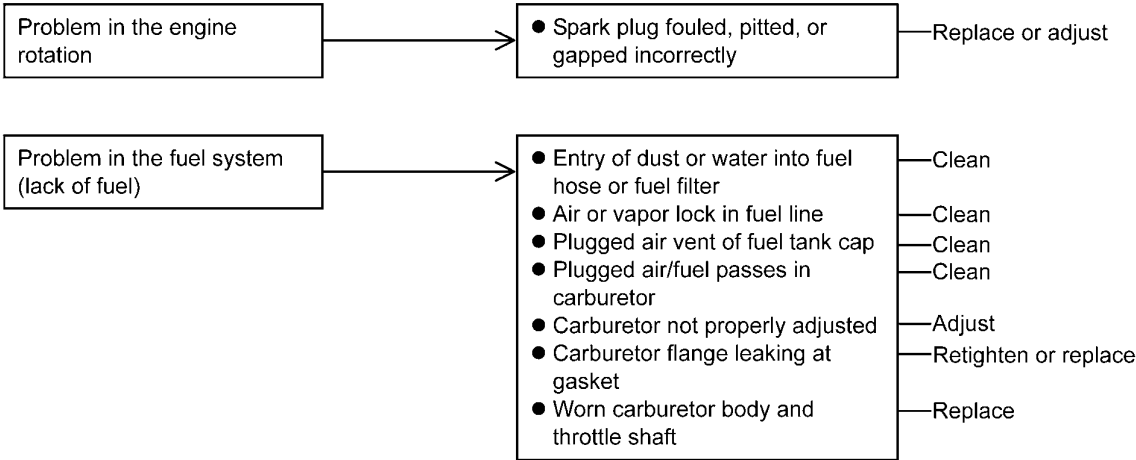

# 10-4 TROUBLESHOOTING

## Engine Troubleshooting Guide

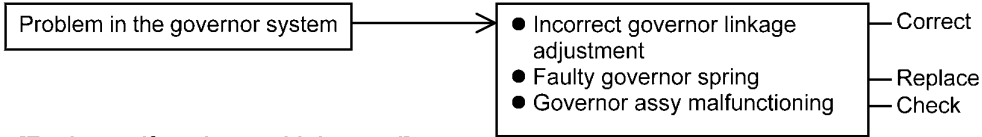

### [Engine malfunctions at high speed]

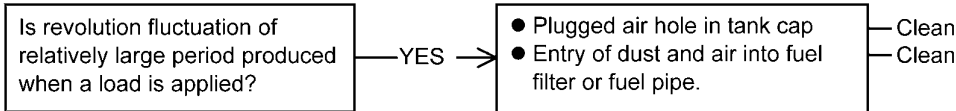

### [Engine malfunctions at low speed]

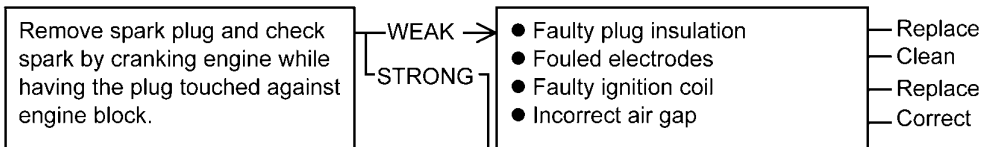

### ⚠WARNING

Spark plugs conduct electricity and can give an electrical shock. Do not hold the spark plug, only hold the plug cap. Keep the plug as far away as possible from the plug hole.

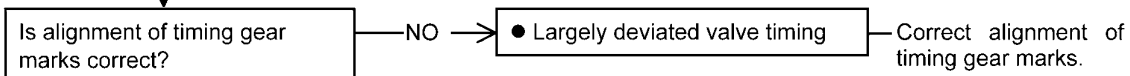
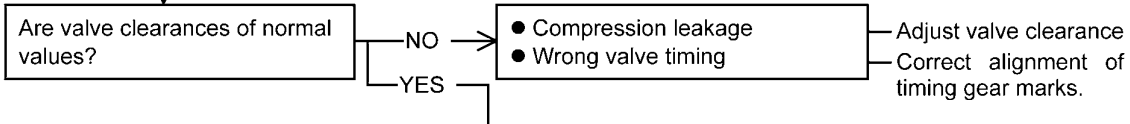
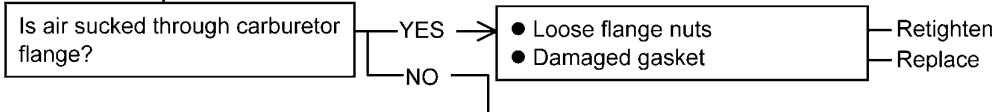
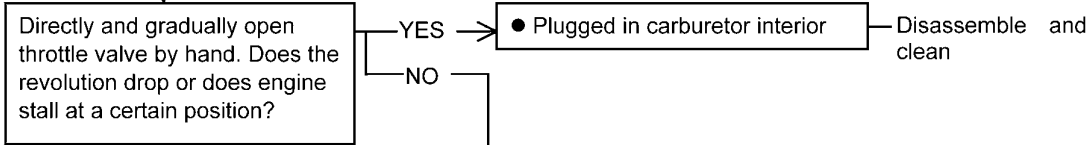
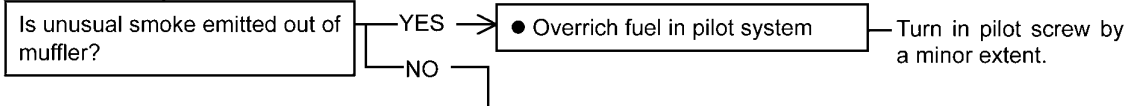

Engine Troubleshooting Guide

[Fuel consumption is excessive]

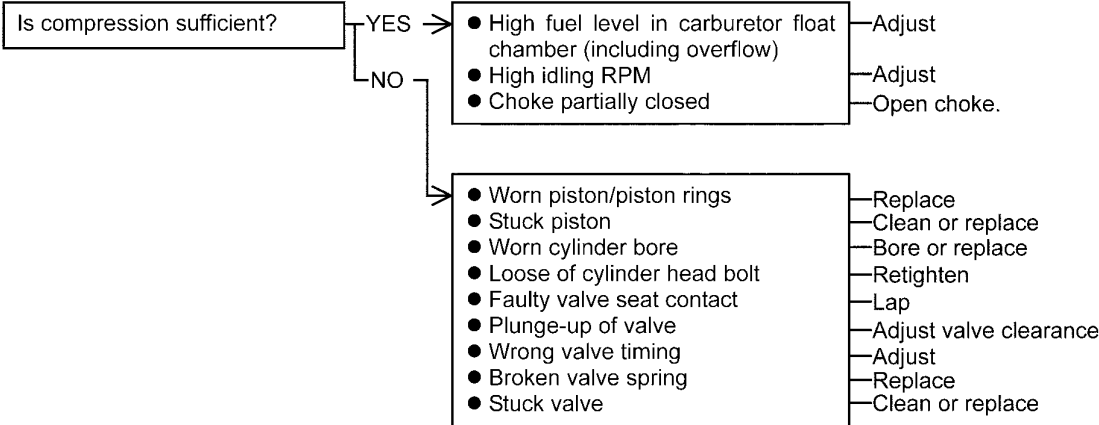

[Oil consumption is excessive]

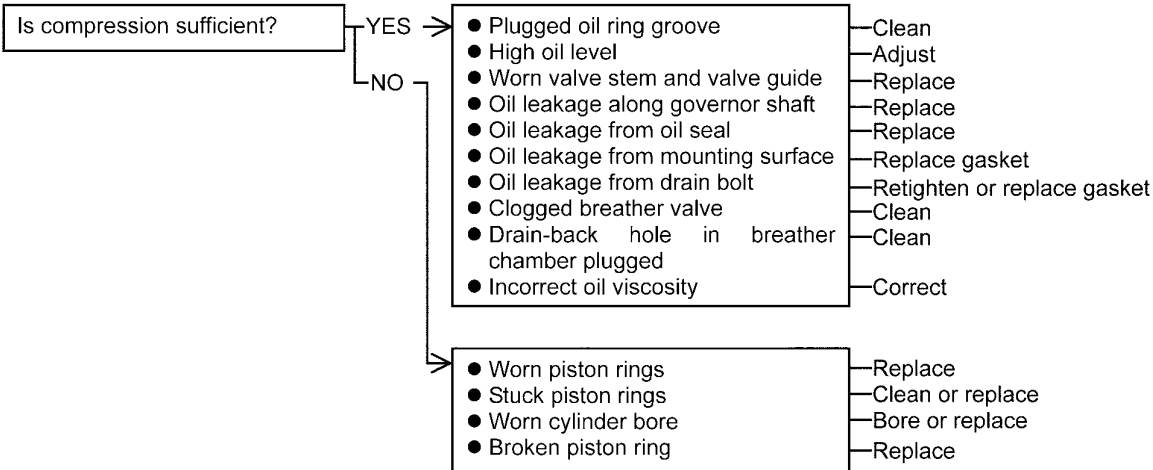

[Engine backfires]

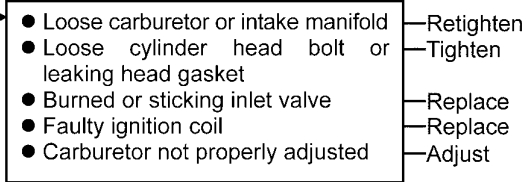

[Engine knocks]

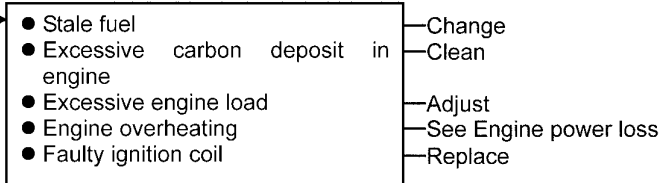

## 10-6 TROUBLESHOOTING

### Starter Motor Troubleshooting Guide

1. Disconnect spark plug caps from the spark plugs.
2. Turn engine switch to "START" position and check condition.

#### **⚠ WARNING**

**Engine may be cranked in this test. Do not touch any rotating parts of engine and equipment during test.**

#### **NOTICE**

**If starter does not stop by engine switch OFF, disconnect negative (-) cable from battery as soon as possible.**

#### **[Starter does not rotate]**

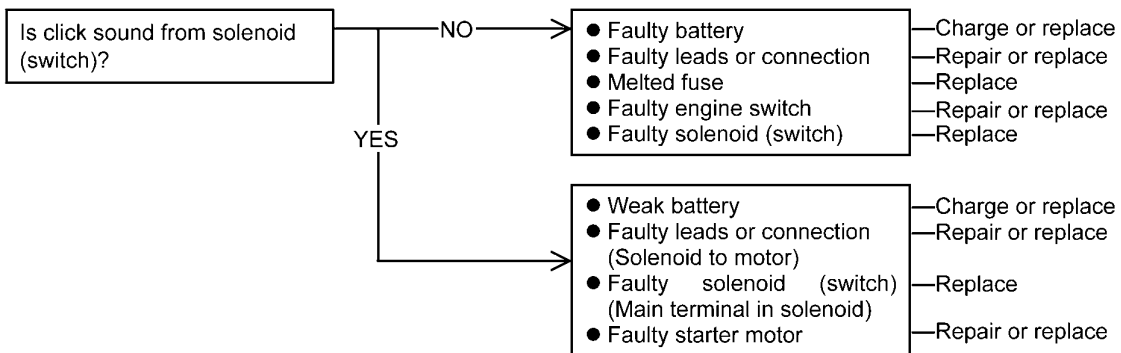

#### **[Starter rotates but slow]**

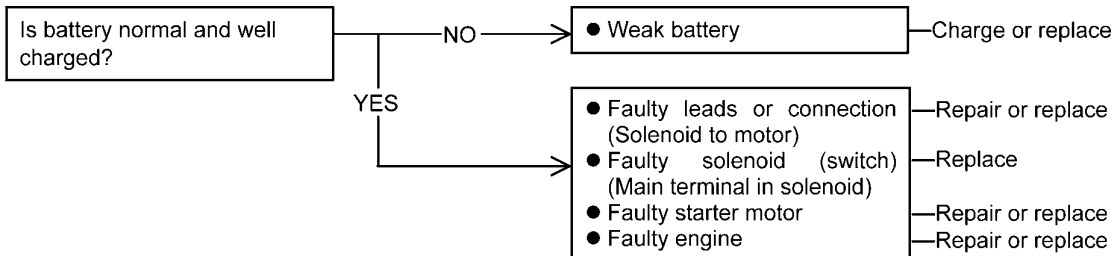

#### **[Starter rotates but engine can not crank]**

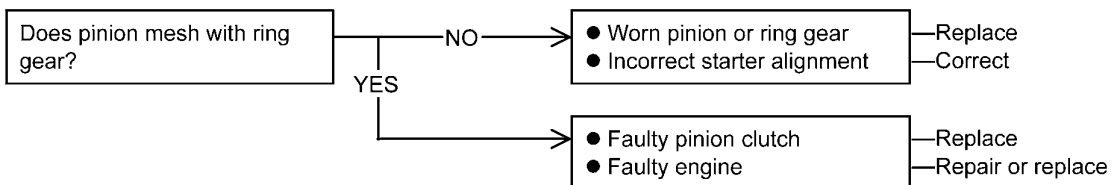

#### **[Starter does not stop in engine switch "OFF"]**

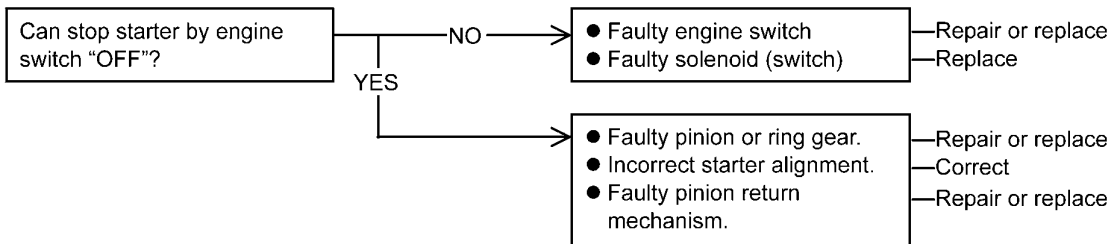



KAWASAKI HEAVY INDUSTRIES, LTD.  
Motorcycle & Engine Company

**Part No.99924-2094-04**

Printed in Japan